



ICE-30 Fast DC Charger Installation and Operation Manual



Version: 3

Last Time Edited: 09/19/2023

In-Charge Energy Inc.

All rights reserved. This manual may be subject to change without notice.

<https://inchargeus.com/>

Service hotline: 818-697-GOEV

IMPORTANT SAFETY INSTRUCTIONS

- Please read the operating instructions and notes carefully before starting operation in order to prevent accidents. The "Caution, Attention, Warning and Danger" statements in the products and product manual do not represent all safety matters to be observed and are intended to supplement various operational safety precautions.
- During the various operations of our products and equipment, it is necessary to comply with relevant National Safety Regulations and strictly observe the precautions and special safety instructions of the related equipment.

Electrical Safety

High Voltage

 Danger	<p>Since some parts of this power system are under high voltage during operation, direct or indirect contact can be fatal.</p>
--	--

- It is necessary to comply with relevant National Safety Regulations during the installation of the Portable DC Charger. Personnel who install and maintain this equipment must be qualified to work with high DC voltage up to 1000Vdc and 3-phase AC voltage up to 500Vac.
- It is strictly forbidden to wear watches, bracelets, bangles, rings, and other conductive objects on the wrist during installation and maintenance.
- If there is water inside the DC Charger enclosure, AC power and DC connector must be disconnected immediately. During operation in a humid environment, water should be strictly prevented from entering the equipment.
- During installation, it is strictly forbidden to operate the DC Charger and an "Operation prohibited" signboard must be used.

 Danger	<p>Construction operation of high voltage lines may cause fire or electric shock. The wiring area and the area where the line passes through for AC cables must comply with national and local regulations and norms. As this device utilizes high voltages do not attempt to install this equipment if you are not a qualified electrician.</p>
--	--

Tools

 Warning	<p>Special tools must be used during various operations involving high DC and AC voltages.</p>
---	--

Thunderstorm

 Warning	<p>It is strictly forbidden to carry out live installation and maintenance work during thunderstorms</p>
---	--

A strong electromagnetic field will be produced in the atmosphere during a thunderstorm. Therefore, the equipment should be well grounded to avoid damage to the equipment due to lightning strikes.

Static Electricity

	<p>Static electricity generated by the human body may damage electrostatic sensitive components on the circuit boards, such as the large-scale integrated circuit (IC), etc. Before handling any patch boards, circuit boards and IC chips, it is necessary to wear an anti-static wrist strap with the anti-static wrist strap wire connected to Ground to avoid damage to sensitive components due to static electricity.</p>
---	---

Short Circuit

	<p>During operation, it is strictly forbidden to short-circuit the positive and negative of the DC Charger DC distribution or short-circuit any DC distribution polarity to Ground. The DC Charger is a high voltage DC power supply, and short circuit may cause damage to the DC Charger and personal safety hazards.</p>
---	---

- During work with High Voltage DC output, it is necessary to strictly check the polarity of cables and interface terminals.
- The space for DC power distribution work is compact and attention should be paid to planning cable routing etc. before starting any installation work.
- Insulated tools must be used.
- During live work, attention should be paid to keeping hands, arms tools etc. away from live high voltage parts to avoid accidents.

Others:

Sharp Corners of Objects

	<p>During the handling of equipment by hand, it is necessary to wear protective gloves to prevent injuries caused by sharp objects.</p>
---	---

Power Cable

	<p>Make sure that the cable label is correct before the connection of cables.</p>
---	---

Signal Cable

	<p>Signal cables should be kept away from power cables, with a minimum distance of 100mm.</p>
---	---

EV Charging Plug

	<p>The use of adapters, conversion sets, and cord extensions are not allowed</p>
---	--

Table of Contents

1 General Product Description	5
2 General Characteristics	5
2.1 Technical Specification	5
2.2 Wiring Diagrams	7
2.3 Model description	8
2.4 Standards	8
3 Product Parts Presentation	9
4 Installation	10
4.1 Safety and compliance	10
4.2 Grounding instructions	10
4.3 Unpacking and visual inspection	10
4.4 Assembly/placing instructions	10
4.4.1 Anchoring to the wall	10
4.4.2 Power cables connections	15
5 Start-Up	19
5.1 Verification and inspection	19
5.2 Switch on	19
6 User Manual	21
6.1 Output connector	21
6.1.1 CCS Connector	21
6.1.2 CHAdeMO Connector	21
6.2 Operation instructions	22
6.3 Operation Indicator Lights	23
Appendix 1 Engineering and Technical Parameters	23
Appendix 2: Maintenance	25
Appendix 3: Maintenance Operation	25
Appendix 4: Alarm information	29
Appendix 5: Error codes and possible solutions	30

1 General Product Description

- The ICE-30 Series Wall Box DC Charger is able to fast charge all electric vehicles compliant with CHAdeMO charging system and combined charging system (CCS) standards.
- Designed to be wall mounted or pedestal mounted, this model is lightweight and versatile. With IP54 level of protection the ICE-30 is also sturdy and durable enough for outdoor applications.
- The battery charging state is displayed on the HMI and the charging cycle finishes by itself or can be interrupted by user command.
- The ICE-30 is user friendly and safe. After user identification, connect the connector to your car then press “Ready” on the HMI. If all safety checks between the vehicle and the EVSE are satisfactory the session will begin.
- Full safety function with output contactor and fuse, ESD/SPD leakage switch, insulation detector software logic for multiple protection schemes.
- LTE wireless modem support, and RFID authorization

2 General Characteristics

2.1 Technical Specification

The Technical Specifications of the ICE-30 are shown in Table 1 on the following page.

This system is intended to have at least one DC output connection (CCS and/or CHAdeMO).

Technical Data		Description	Remarks
Nominal Input	Phases/Lines	3 phases Wye + PE	
	Voltage	380Vac-520Vac (+/-10%)	
	Frequency	50 – 60 Hz	
	Current	39A	
	Power	31.5kW	
	Power factor	≥0.99	
	System Efficiency	≥ 94.5% (Full load)	
Electrical Safety	Recommended Breaker	50A 3W+G Circuit	
	SCCR	10kA (single)	
DC Output CCS1	Voltage	150~1000Vdc	
	Current	100A	
	Nominal Power	30kW (300V)	
DC Output CHAdeMO	Voltage	200~500Vdc	
	Current	100A	
	Nominal Power	30kW (300V)	
Cabinet	Dimensions(W*D*H)	610*270*610 (mm)	
	Weight	194lbs (88kg) (with power module)	
	Protection Degree	IP54, IK10	
HMI and Command Unit	Local interface	TFT Color touch display 7"	
	Communication	Router 4G/5G (GSM or LTE)	
	Protocol	OCPP1.6	
Environment conditions	Operating temperature ¹	-13°F ~ 122°F (-25°C~+50°C)	
	Transportation/ Storage temperature	-40°F~158°F / -40°C~+70°C	
	Humidity	5%RH~95%RH	
	Place of installation	Indoor / Outdoor	
	Altitude	2000m	
	Sound Noise	≤55dB (nominal input/output power, the environment temperature is 77°F (25°C).)	
	Atmospheric pressure	80KPa~110KPa	
	Overvoltage category	II	
	Protection class	Class I	
Note 1: The DC Charger provides full output power up to 45°C, output power derating 5% / °C above 45°C.			

2.2 Wiring Diagrams

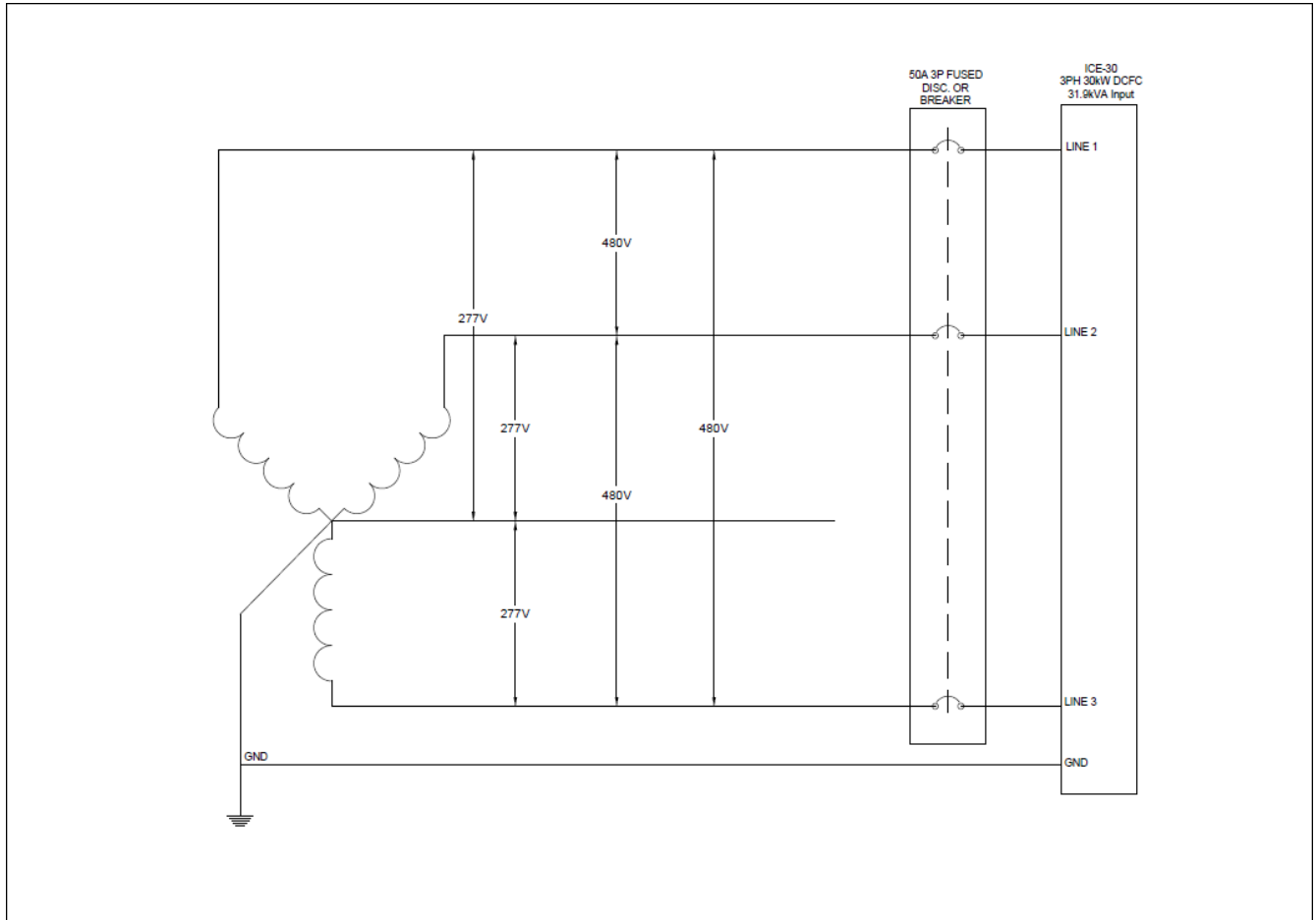

1 ICE-30 3PH 480V
E0.1

Figure 1: ICE-30 Wiring Diagram

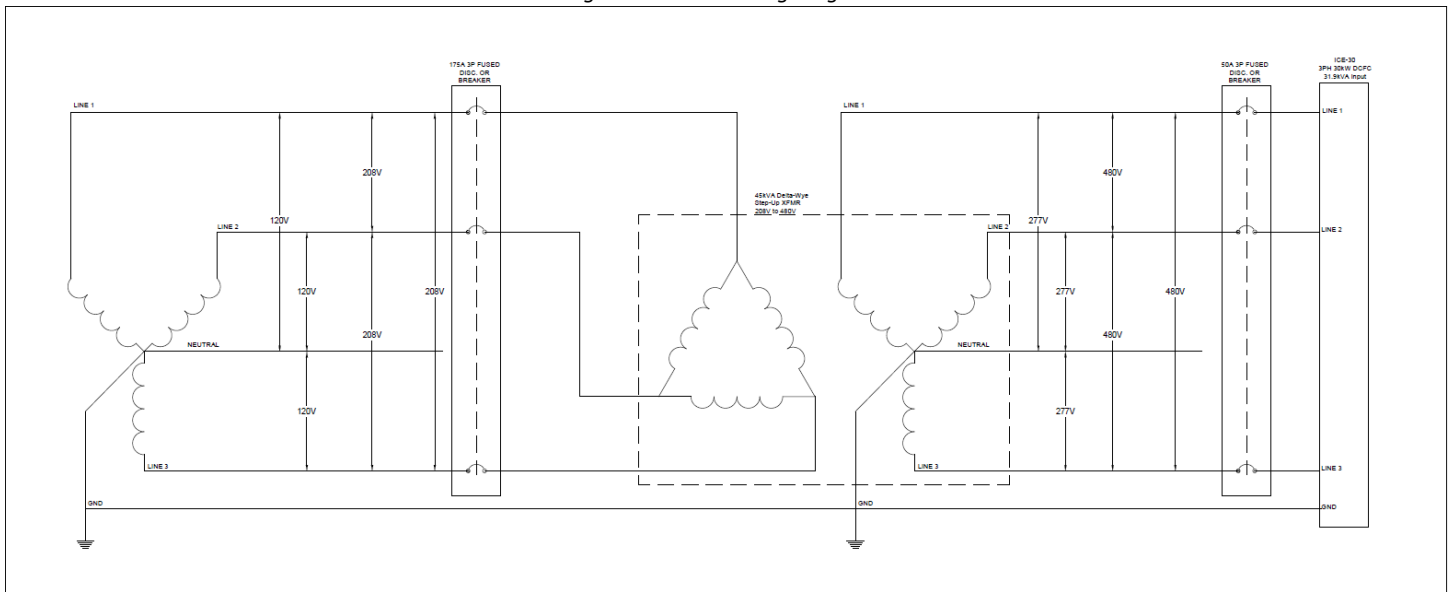

1 ICE-30 3PH 480V (45KVA STEP-UP XFMR)
E0.2

Figure 2: ICE-30 Step-up Wiring Diagram

2.3 Model description

NRTL Model Number	Model	Configuration	Remarks
IDC-30-480-C1C1-WC1R	ICE-30-CC	CCS-1 + CCS-1	30kW
IDC-30-480-C1CH-WC1R	ICE-30-CJ	CCS-1 + CHAdeMO	30kW

2.4 Standards

The EVSE (Electric Vehicle Supply Equipment) complies with the following standards:

Table 2 Applicable Standards

Technical Data	Norm	Remarks
Applicable Standards	IEC 61851-1 ¹ IEC 61851-23 ² IEC 61851-24 ³	

- 1 IEC 61851-1 2017:** Electric vehicle conductive charging system. Part 1: General Requirements
- 2 IEC 61851-23 2014:** Electric vehicle conductive charging system - Part 23: DC electric vehicle charging station
- 3 IEC 61851-24 2014:** Electric vehicle conductive charging system - Part 24: Digital communication between a DC EV charging station and an electric vehicle for control of DC charging

3 Product Parts Presentation

The charging system is composed of DC charging cabinet and DC charging connector. The System can be installed outdoors.

The ICE-30 fast DC Charger has various possible output combinations as shown below :



Figure 3: External View of ICE-30

4 Installation

4.1 Safety and compliance

Since the working voltage inside the charging system is very high and the current is very large, the following rules should always be observed to ensure personal safety:

- Only personnel who have received the training of the charging system and fully mastered the knowledge of the charging system can install the charging system. During installation, always observe the safety precautions mentioned in this document and all relevant National Safety Regulations.
- It is necessary to make sure that the charging system DC output is disconnected in the case of operation inside the charging system. The mains input of the charging system must also be disconnected.

4.2 Grounding instructions

An equipment grounding conductor or a grounded, metal, and permanent wiring system is required for the EVSE charger connection. This should be run with circuit conductors and connected to the equipment grounding bar or lead on the EVSE.

4.3 Unpacking and visual inspection

- Check that the exterior packaging has not been damaged by mechanical impacts or any accidents during transportation
- If applicable, check that the exterior panels of the ICE Charger are in perfect condition
- Check that the interior of the Charging Station is clean
- Check that the door of the Charging Station is working properly
- Check for proper Charging Station protective ground connection point, which should be interconnected with the low voltage switchboard ground connection during the installation

4.4 Assembly/placing instructions

4.4.1 Anchoring to the wall

- The wall mounted assembly consists of a back plate and two charging gun holsters. The EVSE is fastened to the wall via the back plate.
- The figure below shows the power cabinet drilling layout
- The position of cable entrance is indicated by the red line in figure 4 below

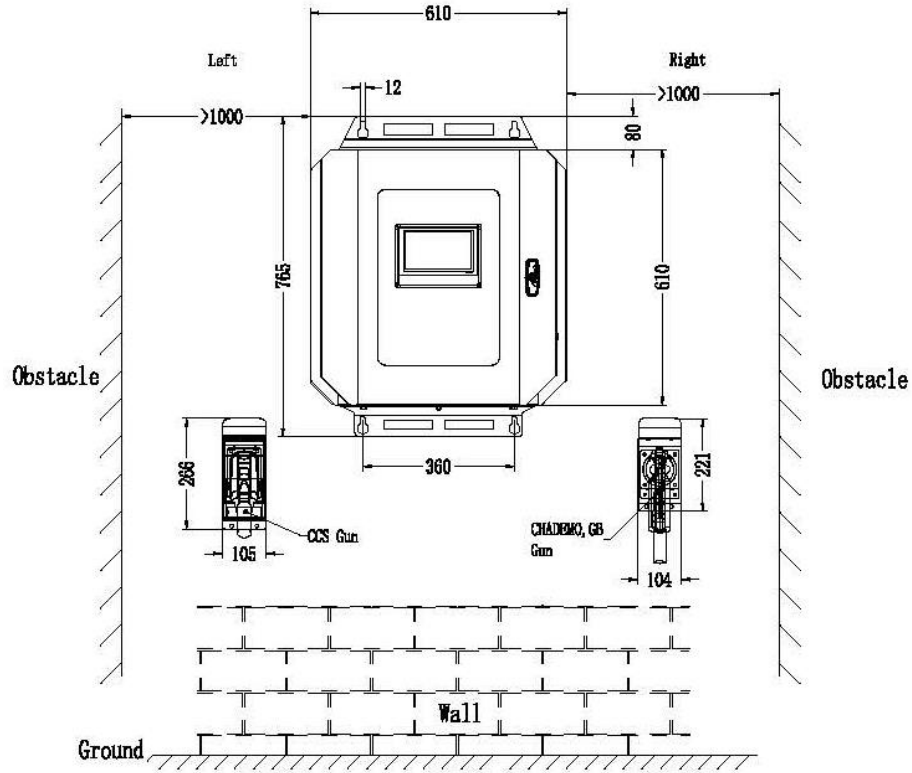

Figure 4: Drilling and Conduits layout

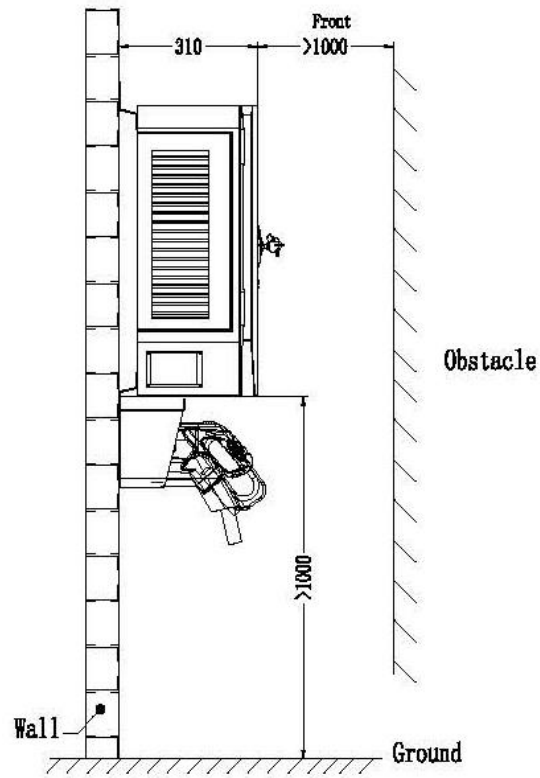

Figure 5: ICE-30 Space Requirement

4.4.1 Table

Position	Screw Specification	Quantity
Wall Mounted		
Between the back plate and the body	Combination screw, M6 * 16mm	6 pcs
Between the back plate and the wall	Expansion screw, M8 * 30mm	4 pcs
Between the gun holster and the wall	Expansion screw, M6 * 16mm	3 pcs/gun

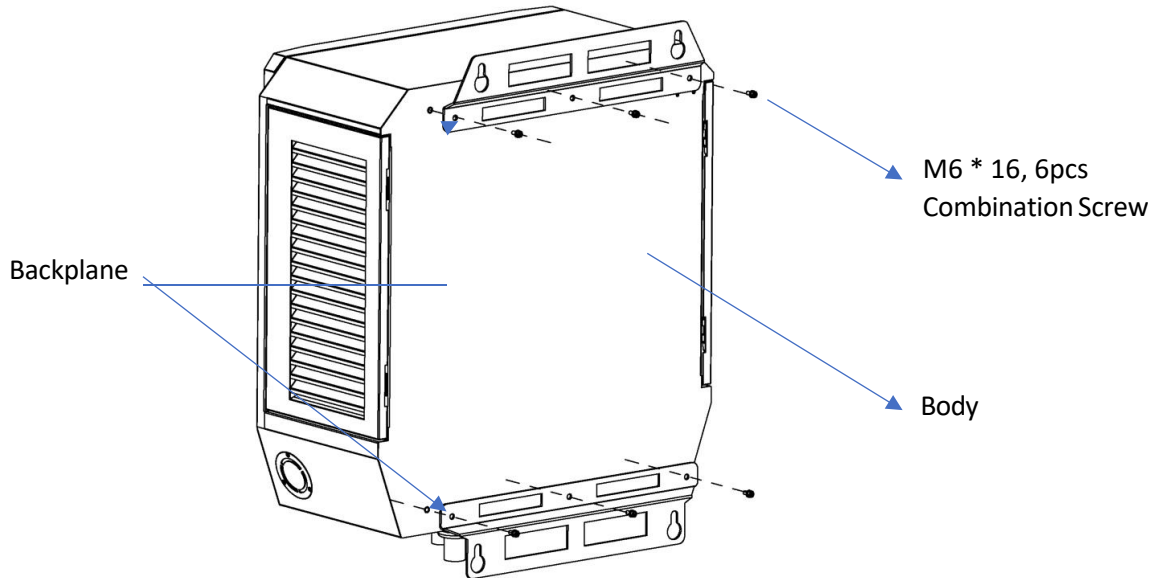

Figure 6: ICE-30 Bracket bolt pattern

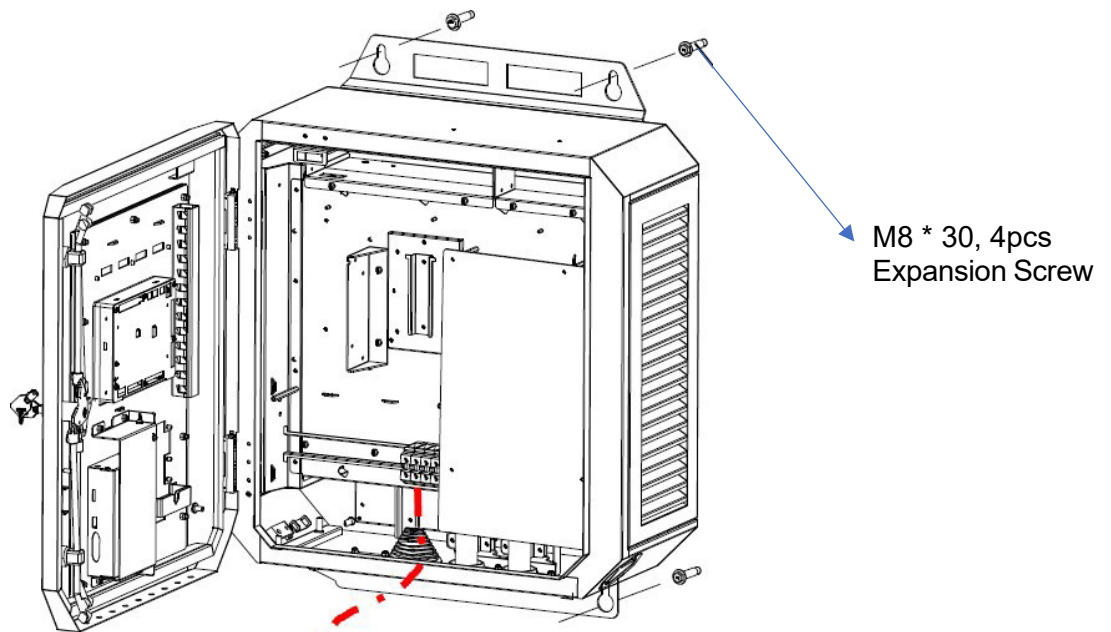

Figure 7: Grid input wiring

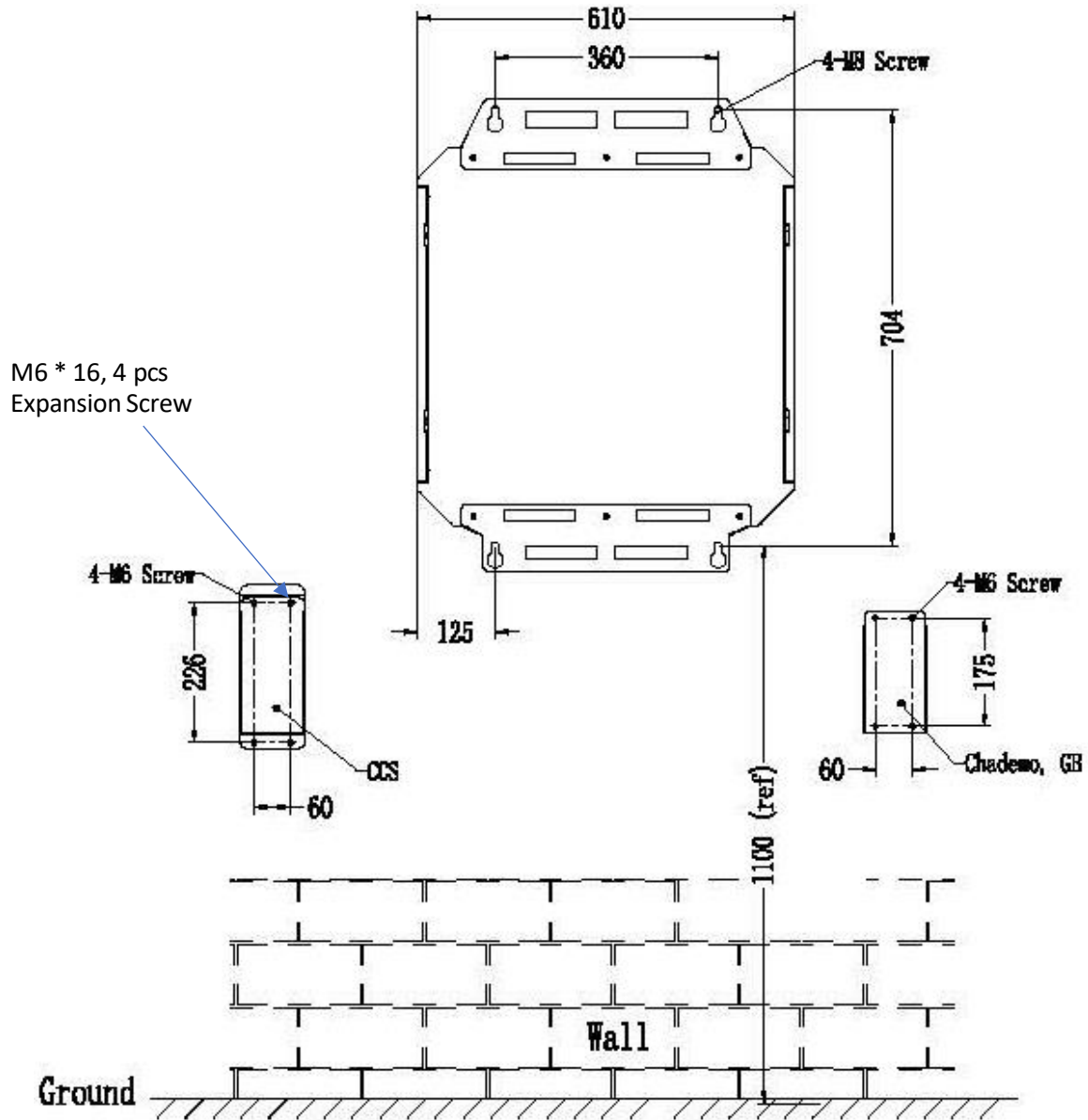

Figure 8: Back hole dimensions

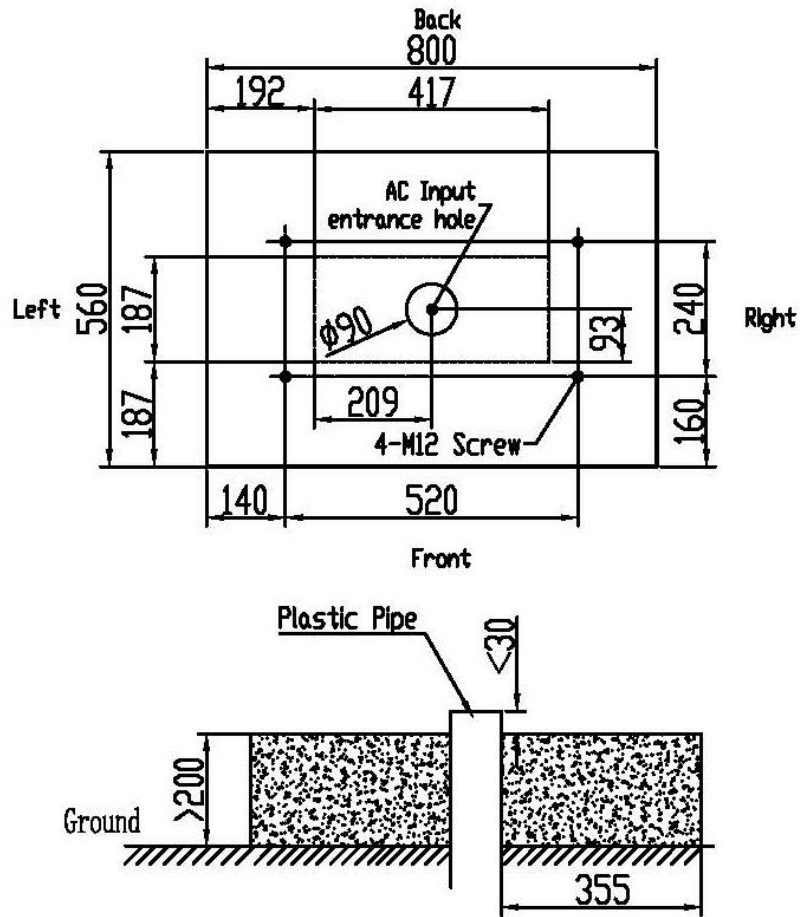

Figure 9: Concrete foundation view

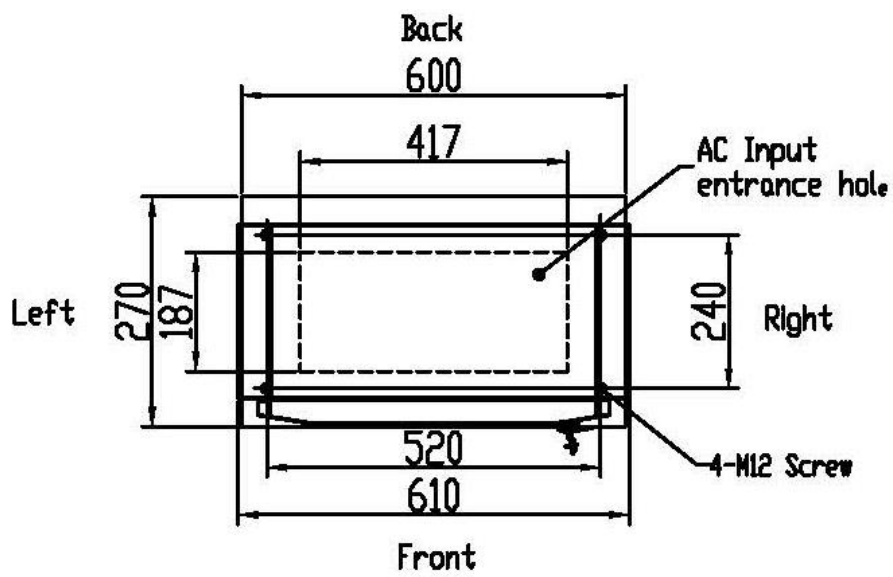

Figure 10: Top view

4.4.2 Power cables connections

End terminals for input wiring: 4 (four) end terminals for 3 phases + protective ground.

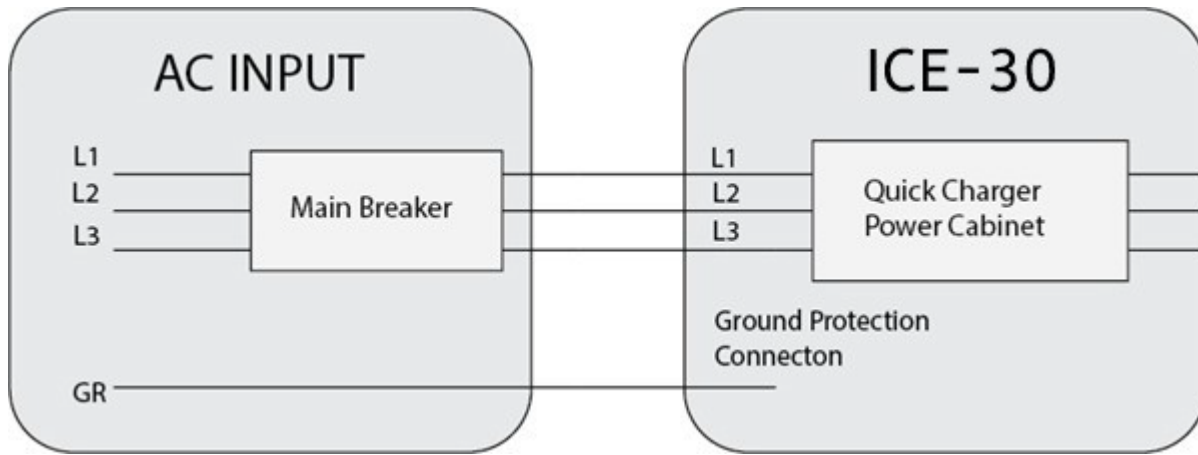

Figure 11: AC Input Wiring

Table 7: AC Input Wiring Cables

NO.	The section for AC feed cables	Amperage	Max. Power of charger	Specification of terminal screw	Torque Specifications
1	3*185+2*95mm ²	48A	30kW	L1/L2/L3 is M6 PE is M8	M6: 36in-lbs / 4.07 Nm M8: 8ft-lbs / 10.85 Nm

Notes:

- The AC feed power cables to the charger are not included.
- The protective MCCB must be installed on the customer's distribution cabinet, and the upper MCCB capacity shall not be less than 1.25 times of the input current.
- It is recommended that the upper MCCB not be equipped with RCD function.
- The section for feed cables is 10 to 25mm². However, within this range, selected section is based on the distance between distribution board and charger (to be decided by customer's electrician for installation).
- This system is to be connected to a grounded, metal, permanent wiring system; or an equipment-grounding conductor is to be run with circuit conductors and connected to equipment-grounding terminal or lead on battery charger.

Note

 Caution	Before electrical connection, all switches must be switched off.
---	--

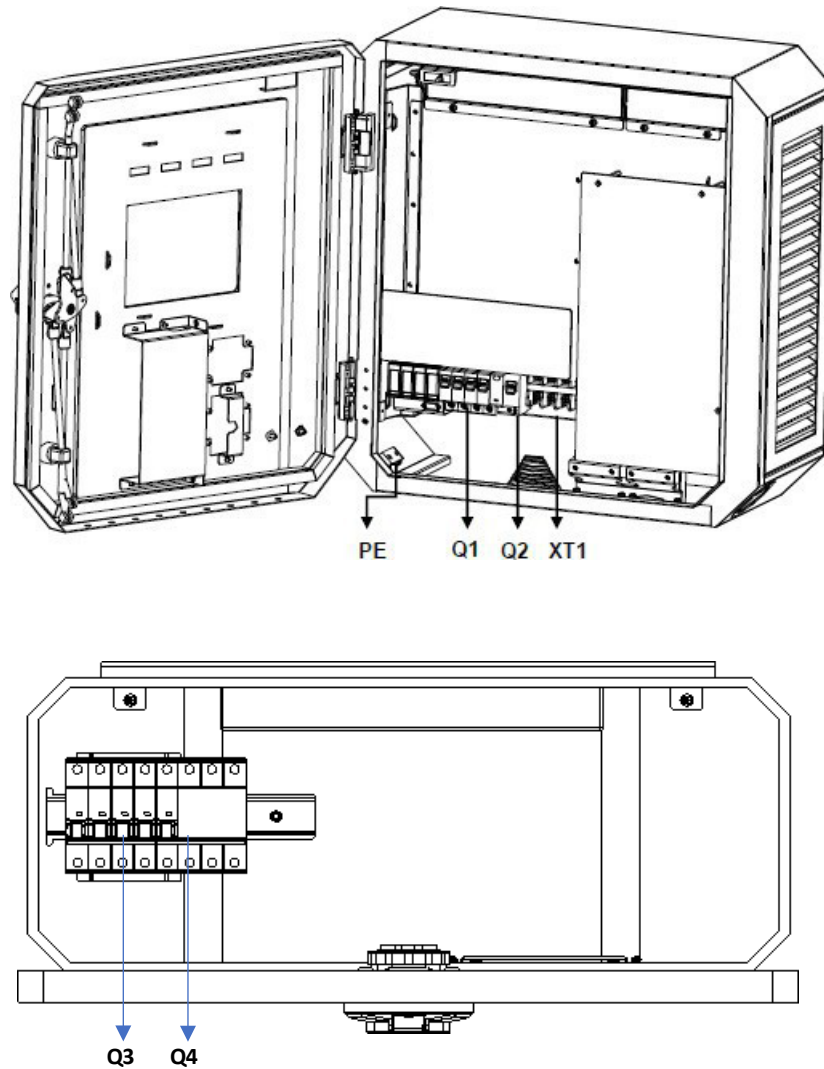

Figure 12: UL Wiring Diagram

- ※ PE: Earth Bus Bar
- ※ XT1: Power main input-Terminal Block: L1 L2 L3 N
- ※ Q1: AC Input MCB For Rectifier Module
- ※ Q2: AC Input RCD For Auxiliary Power
- ※ Q3: AC output-power main input MCB
- ※ Q4: AC output-power main input RCD

STEP-1



STEP-2



STEP-3



STEP-4

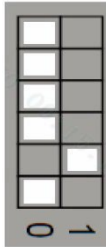

- ※ **Step-1:** Remove the nuts in the cabinet (marked with a red circle).
- ※ **Step-2:** Insert the power module
- ※ **Step-3:** Tighten the retaining screw to secure the module.
- ※ **Step-4:** Set the Address of the power module (marked with a red rectangle), follow the below picture.

Case	Connector Type	Rectifier Panel Switch
1	CCS1+CCS1	 High ← Low
2	CCS1+CHAdeMO	



 Caution	Power modules are heavy, please exercise caution when moving modules.
---	--

5 Start-Up

5.1 Verification and inspection

- Check if the bolts of the AC and protective ground cables of the EVSE are correctly tightened to the specified torque. The torque values are as follows:
 - M8: 8ft-lbs (10.85 Nm)
 - M6: 36in-lbs (4.07 Nm)
- Check the resistance between the EVSE protective ground and the low voltage switchboard ground connection; the value must be according to local codes.
- Check the resistance on the Grid AC between phases and between phase and PE. Also check resistances between DC+/DC-/PE to ensure no dead shorts.
- Check that power modules panel address setting is correct.
- Before switching ON all the fuses and circuit breakers, check the supply voltage between lines: it must be 380Vac-520Vac. Also check between phases and phase to ground. Voltage should be 480V +/- 5% P to P and 277V +/- 5% P-PE for a 480V feed

5.2 Switch on

- Switch on the circuit breakers in the charging pile, Q1 and Q2 in turn.

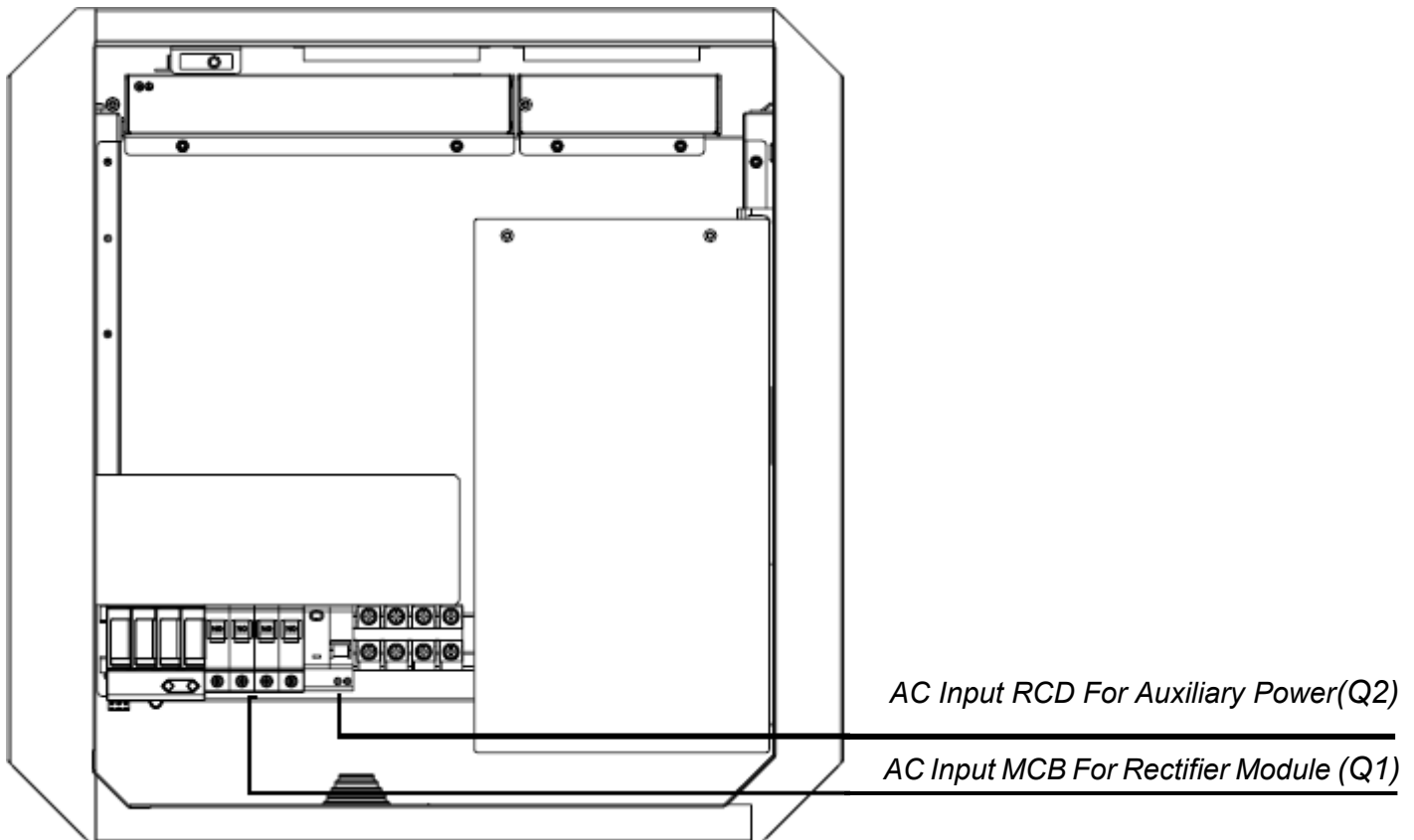

- Wait for a few seconds. The display will present a picture as below



Figure 13: Loading Screen

- Finally, the display will present the following charging screen

CCS1+CHAdeMO Units:

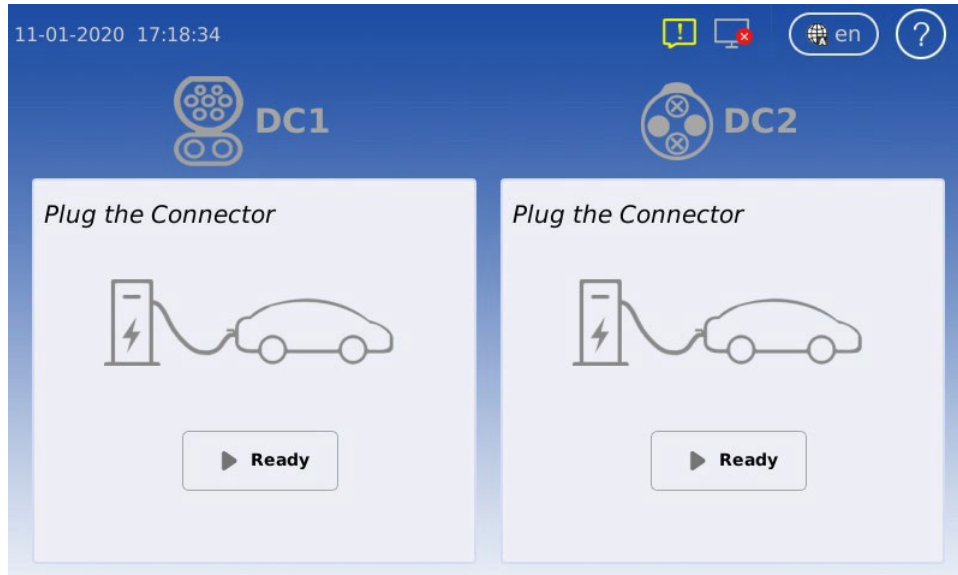

Figure 14: Charging screen



Before attempting to install or start up the charger must ensure that the safety instructions in this manual have been carefully read and observed by trained personnel. Keep this manual with the charger for future reference.

6 User Manual

The EVSE operation depends on its output connections: CCS or CHAdeMO. During the charging process, the Human Machine Interface (HMI), will give instructions and will signal different stages. These sequences are shown in this chapter.

6.1 Output connector

The EVSE is prepared to charge electric vehicles according to the mentioned charging systems

6.1.1 CCS Connector

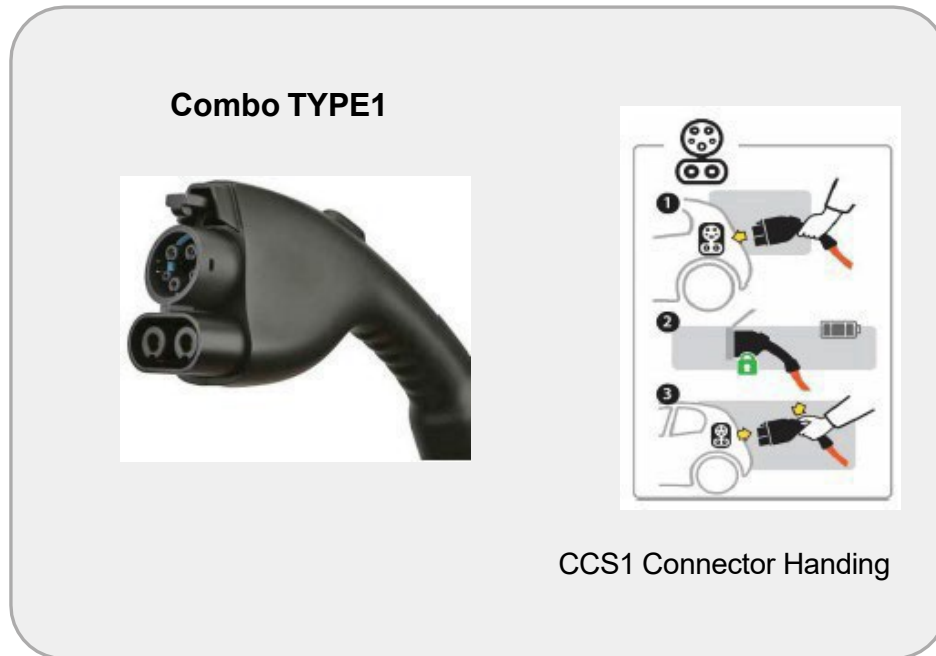

Figure 15: CCS1 Connector

6.1.2 CHAdeMO Connector

CHAdeMO connector has a lock button.

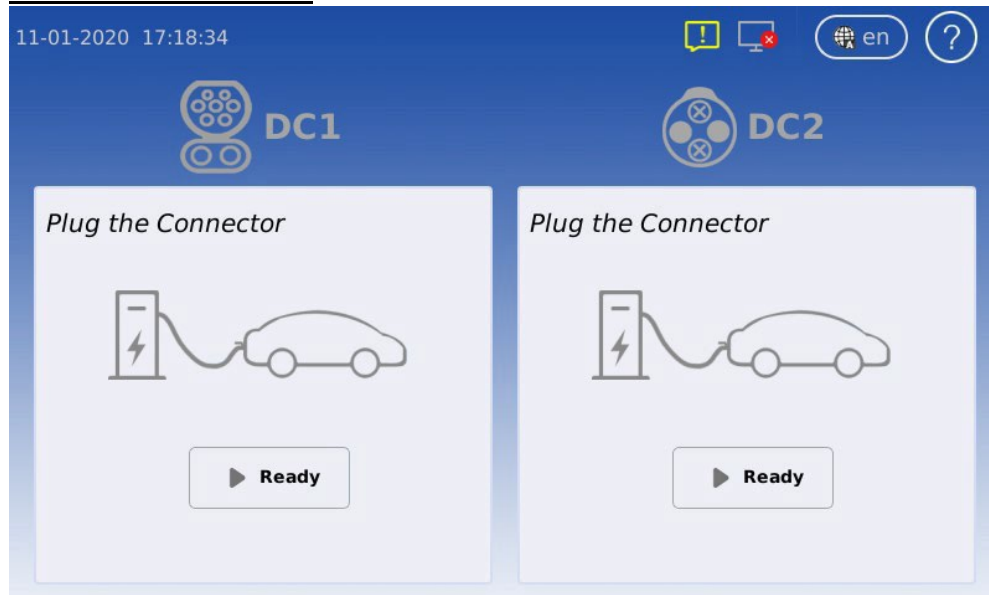

Figure 16: CHAdeMO

6.2 Operation instructions

When a user starts an operation on the EVSE, the HMI display will show one of the following screens.

CCS1+CHAdeMO Units:



- 1、 Plug the charging gun into the vehicle receptacle.
- 2、 Press “Ready” on the screen.
- 3、 Wait for the charging session to begin.
- 4、 After the vehicle is fully charged, stop charging first, then unplug the charging gun.

6.3 Operation Indicator Lights

The Indicator lights that are located above the screen show the chargers current state.

Light Info:

Indicator Light Location (Left to Right)	Color	Meaning
DC-1	Yellow	DC-1 Is currently in use
POWER	Green	Power is active
ALARM	Red	Any type of error is present
DC-2	Yellow	DC-2 is currently in use

Appendix 1 Engineering and Technical Parameters

- ※ The DC Charger has left and right-side doors. A minimum of 40in (1000mm) clearance should be provided on both sides to provide space for maintenance.
- ※ Hot ventilation air exits to the left. A minimum 40in (1000mm) clearance should be provided to prevent hot air from recirculating back to the air intake.



Note: When the system is running, the temperature of the left-side door will be hot so avoid contact.

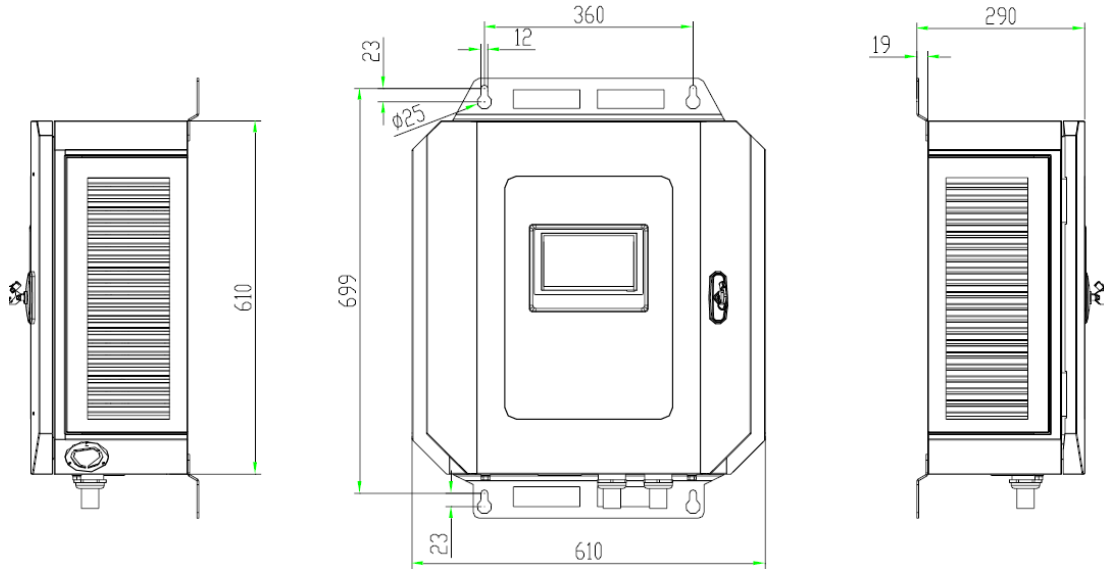

Figure 17: ICE-30 side views

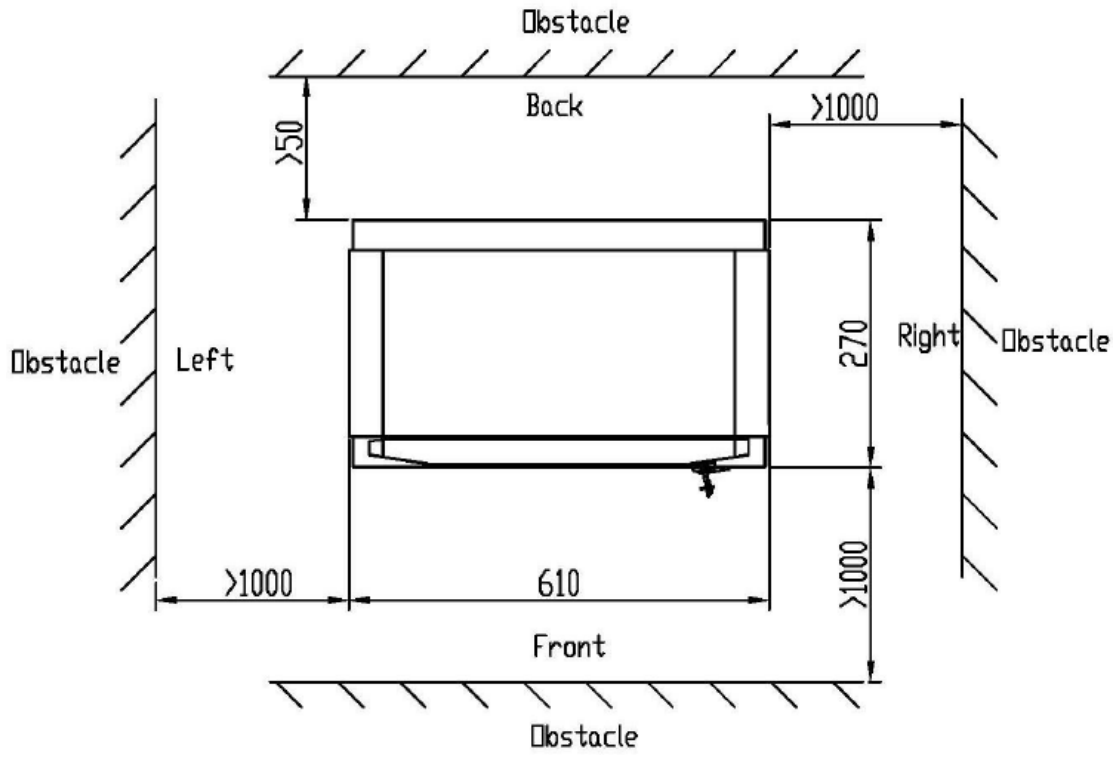

Figure 18: EVSE Space Requirement

Appendix 2: Maintenance

1 Maintenance Table

NO.	Position	Method	Tool	Maintenance cycle
1	AC Input for Auxiliary Power	Visual Check	N/A	2 months
2	Devices and connection points: Main circuit devices (circuit breaker, AC contactor, DC contactor, DC fuse), copper bar, power module connector	Visual Check	Torque Wrench	2 months
3	AC SPD	Visual Check	N/A	3 months
4	Charging Plug	Visual Check	Brush	Daily
5	Cooling fan and filter cotton	Visual Check	Blower, Screwdriver, Soft Brush, Vacuum Cleaner	3~6 months
6	ESD	Visual Check		Daily
7	Alarm information check	Visual Check		Daily

Appendix 3: Maintenance Operation

2.1 AC Input RCD For Auxiliary Power

1. When the circuit breaker is in the closed state, press the trip test button to test the trip function of the circuit breaker.
2. After the trip button is released, the recovery method is as follows: first turn the circuit breaker to the switch off state, and then turn it to the switch on state.



2.2 Devices and connection points

- 1) Check the connection points(circle in the picture)between the main circuit components (circuit breaker, AC contactor, DC contactor, fuse) and copper bar or cable, the connection points between copper bar and copper bar, and the connector of power module for burns or serious discoloration. If damage is found please check the torque and connection according to point 2) and replace the damaged components if required;
- 2) Check whether the screw fixing torque mark is normal. If there is any deviation, please re-torque with a torque wrench and mark with a marker.

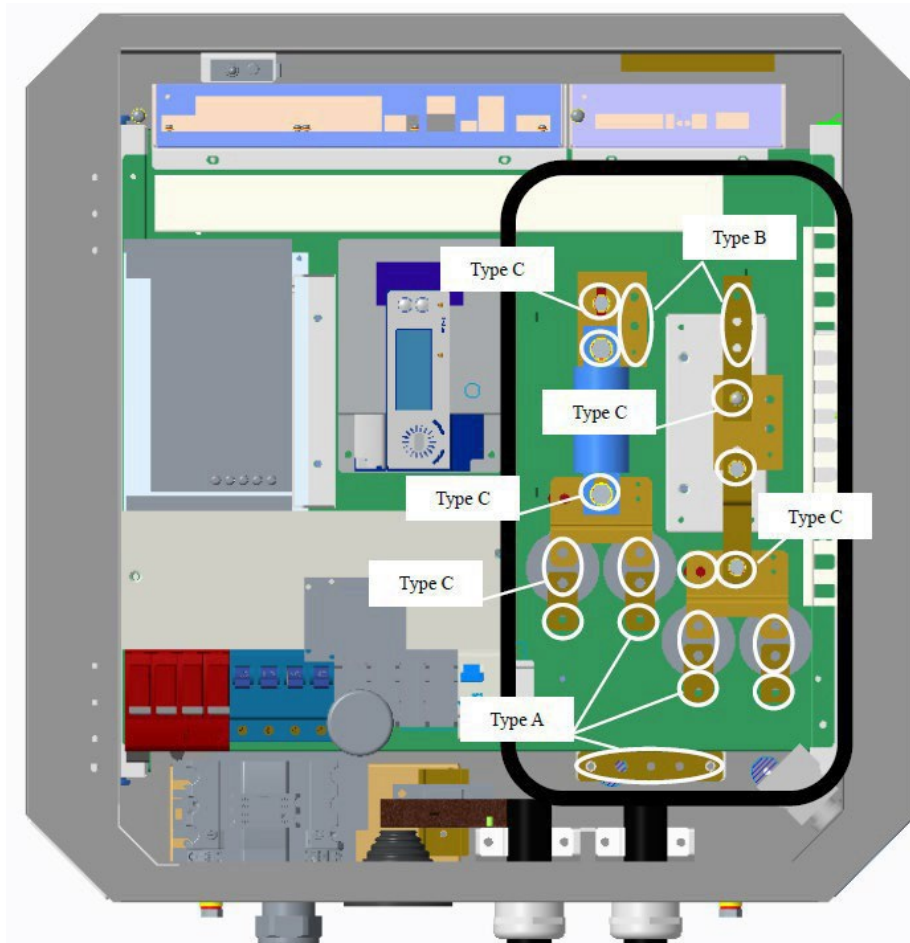
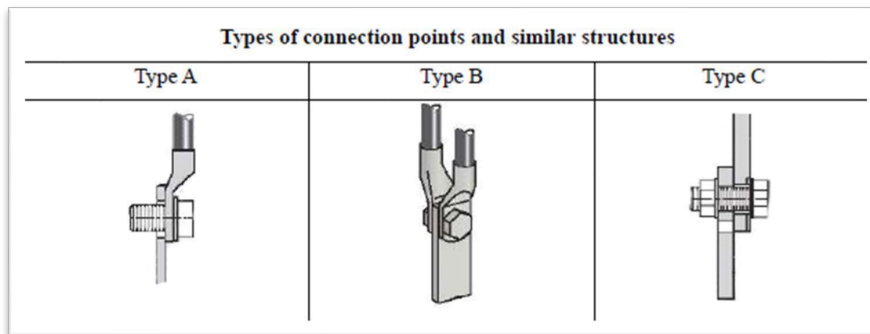

2.3 AC SPD

Check the status window of SPD. If the window color changes from green to red, it indicates that SPD has been detected, contact the manufacturer for replacement

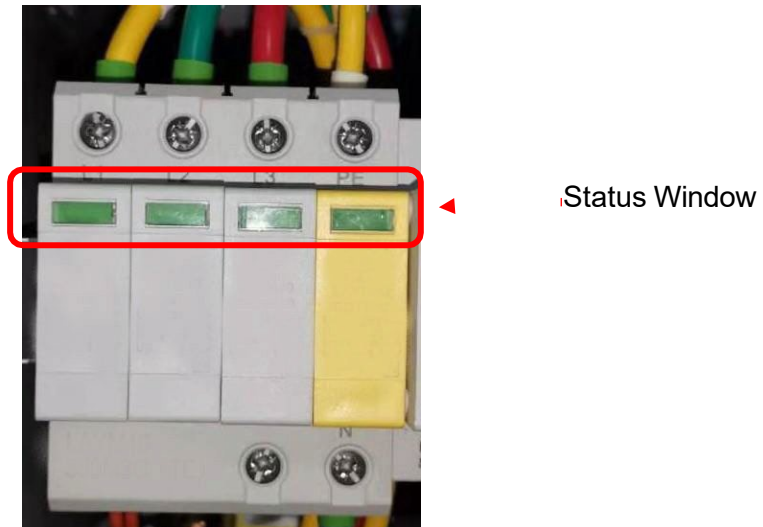

2.4 Charging plug

- 1) Check whether the charging plug is cracked or damaged. If so, please contact the manufacturer.
- 2) Check whether the DC + and DC -terminals of the charging plug have obvious burning marks. If so, please contact the manufacturer for replacement or repair.
- 3) Use a brush to remove the dust on the surface of DC+ and DC -terminals.

CCS1

DC+ and DC- Terminals



CHAdeMO

DC+ and DC- Terminals



2.5 Cooling Fan and Filter cotton

- 1) Check the dust screen on both sides of the heat exchanger for dust.
- 2) Use the a brush or cloth to clean the dust on the dustproof net.
- 3) Depending on the site environment, the dust net shall be effectively removed at least once every three to six months, and it shall be replaced once a year at most.
- 4) Remove the dust screen with a screwdriver, and use a soft brush, blower, and vacuum cleaner to remove the dust effectively.
- 5) Use vacuum cleaner and soft brush cloth to effectively remove the dust and debris in the cabinet.

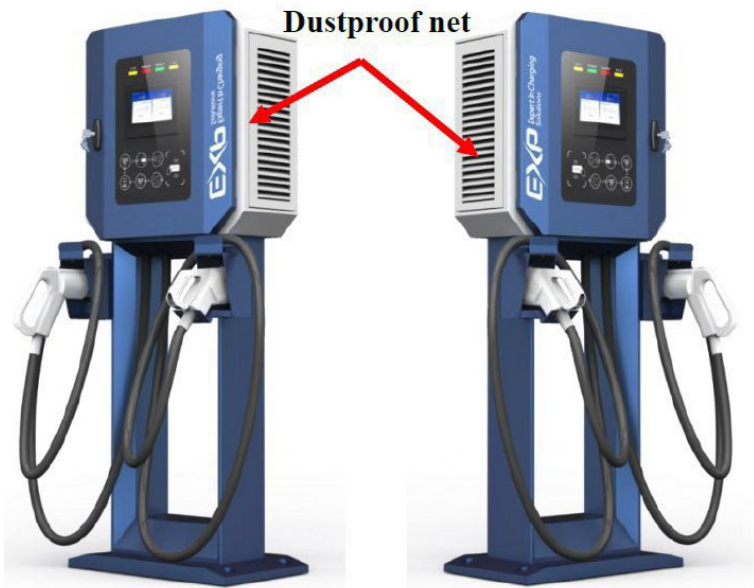

Cotton Filter



2.6 ESD

Check the emergency stop cover plate. If the cover plate is damaged, please contact the manufacturer for replacement.

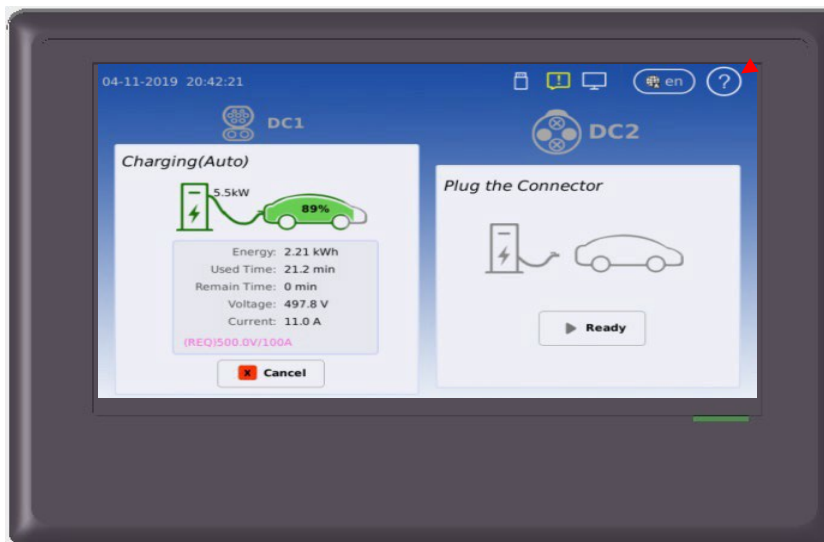

Figure 19: ESD and cover plate





Appendix 4: Alarm information

- 1) Click “?” In the upper right corner of the screen to view the error code/alarm information.
- 2) If an alarm is displayed it should be addressed immediately. If it cannot be resolved, contact the manufacturer for assistance.

Click here to view alarm information



Appendix 5: Error codes and possible solutions

26-03-21 15:03 (Engineer)    en 

Active Alarm Detailed Info Param Set Manual Ctrl Charge Rec

Index	Level	Alarm Name	Source	Begin Time	Status
1	MA	Server Comm Fail	Charger System	2021/03/10 15:10:39	Started
2	CA	Communication Failed	Heat Exchange	2021/03/26 15:00:17	Started

◀ 1/1 ▶

Table: Charger_Alarms					
NO.	Alarm_ID	Alarm_Name	Alarm_Level	Description	Remark
1	1	System Not Available	CA	System is out of service and charge is not allowed. This usually comes after other critical alarm(e,g EPO pressed)	
2	2	System Disabled	MA	System is out of service and charge is not allowed. This happens after system is set to 'In-operative' by service guy or backend.	
3	3	All CCU Comm Fail(Not used right now)	CA	Note used any longer	
4	4	Server Comm Fail	MA	If the network is not accessible or the connection between server and charger is broken	
5	5	All kWh Meter Not Installed	MA	All kWh meters are set to 'Not installed'. This means the system is not available	
6	6	CCU Comm Fail	CA	The communication between IMMU2 and IMSU-D has failed. This means the system is not available	
7	7	EPO is pressed	CA	This means system not available	
8	8	Door is opened	CA	This means system not available	
9	9	SPD alarm	CA	This means system not available	
10	10	Mains Fail Alarm	CA	This means system not available	
11	11	Gun is disabled	MA	The specified gun is out of service and not allowed to charge. This happens after the gun is set to 'In-operative' by service technician or backend.	Gun A/B/C shall be specified
12	12	System over temp	MA	The temperature measurement from sensor	Note that this alarm does not stop/prohibit charge function

				is over the upper limit point(default is 75 'C)	
13	13	All Rectifier Failure	CA	This means system not available	
14	14	All Rectifier Comm Fail	CA	This means system not available	
15	15	Rectifiers Failure	CA	This means the specified gun will not be available	Rectifier group 1/2 shall be specified
16	16	Rectifiers Comm Fail	CA	This means the specified gun will not be available	Rectifier group 1/2 be specified
17	17	Insulation Comm Fail	CA	This means the specified gun will not be available	
18	18	Output Shorted	CA	This is from Rectifiers after detected the internal circuit shorted	
19	19	Insulation Alarm	CA	This is from IMSU-D after detected the insulation abnormal	
20	20	PLC ComFail Alarm	CA	This is from IMSU-D when the PLC communication is lost	
21	21	Ground Fault	CA	This is from IMSU-D after detected ground fault	
22	22	AC Fail Alarm(for AC only)	CA	This is from IMSU-D after detected AC gun input fails(DI)	
23	301	CR CommFail	CA	The communication between IMMU2 and Card Reader is failed. This usually means the authentication with RFID card loses efficacy and user has to take other method instead(e,g OTP)	
24	401	kWhMeterCommFail	CA	The communication between IMMU2 and specified kWh meter is failed. This means the specified gun will be out of service and forbid to charge	
25	402	Sampled Invalid Current	CA	The measurement from the specified kWh meter is invalid. This usually happens with a reversed	

										wiring for the current shunt.
<i>1. CA - Critical alarm MA - Major alarm OA - Observative Alarm</i>										

Stop Reason Classification	Code	Description	Remark
Normal Stop	1	Normal Stop	Condition satisfied
	2	EV Request Stop	EV Request Stop
Charger Error	201	Parameter configuration failed	
	202	Charging Enable timeout	
	203	Abnormal volt of outside bus	
	204	Unable lock charging gun	
	205	Insulation inspection anomaly	
	206	Insulation inspection timeout	
	207	EV Relay pull-In timeout	
	208	Require Curr Timeout	
	209	Remain time over stop	
	210	Ring fail alarm (reserved)	
	211	Communication with EV failed	
	212	Plugged gun timeout	
	213	Pre Charging fault	
	214	DoorOpen	
215	EPO		
216	SPD		

	217	AllRectFail	
	218	MainsFailAlm	
	219	AllRectCommFail	
	220	E_LockFail	
	221	GunOverTemp	
	222	OutputShortCircuit	
	223	PWM Failure	
	224	Ground Fault Detected	
	250	CR Comm Fail	
	251	kWhMeterComm Fail	
	252	CCU Comm Fail	
EV Error	301	Battery overvoltage	
	302	Battery undervoltage	
	303	Battery current deviation error	
	304	High battery temperature	
	305	Battery voltage deviation error	
	306	Charger Connector Lock Fault	
	307	Vehicle shift position	
	308	Error Status Noticed by EV	
	309	PLC Low Level Comm Fail	
	310	PLC High Level Comm Fail	
	311	PLC Authentication Timeout	
312	PLC ParamDiscovery Timeout		
Canceled	401	Local Stop	
	402	Server Stop	
	403	Network fault	

	404	Reboot	
	405	DeAuthorized	
	406	One-Click Stop	
	407	Hard Reset	
	408	Soft Reset	
Other	501	Other	