

 InCharge™

ICE-360/480 Installation and Operation Manual



Version: 1.4

Last Edited: 4/6/2026

InCharge Energy Inc.

All Rights Reserved. **This Manual May Be Subject to Change Without Notice**

Failure to follow the installation and operation manual may void the EVSE warranty.

<https://inchargeus.com/>

Service Hotline: 818-697-GOEV

Contents

1.) IMPORTANT SAFETY INSTRUCTIONS	5
1.1) Electrical Safety	5
1.2) Tools.....	5
1.3) Thunderstorm.....	6
1.4) Static Electricity	6
1.5) Short Circuit.....	6
1.6) Sharp Corners of Objects.....	6
1.7) Power Cable.....	6
1.8) Signal Cables.....	7
2.) General Product Description	8
2.1) Main Features	8
3.) General Characteristics	9
3.1) Technical Characteristics	9
3.2) Model Description.....	17
3.3) Standards	17
4.) Product Parts Presentation	18
5.) Installation.....	20
5.1) Safety and Compliance.....	20
5.2) Grounding Instructions	20
5.3) Unboxing and Visual Inspection.....	20
5.4) Assembly/Placing Instructions	20
5.4.1) Preparation of Concrete Foundation	21
5.4.2) Power Cabinet Installation	24
5.4.3) Slim Line Dispenser Installation	25
5.4.4) Micro Dispenser Installation (Wall/Overhead)	26
5.4.5) Power and Signal Cable Connections.....	30
5.4.6) Power Module Installation	40
5.5) Controller Setting	41
5.5.1) Address Settings	41
5.5.2) Resistance Setting	42

6.) Adding Cooling Liquid	45
6.1) Charging Dispenser Cold Source Description.....	45
6.2) Liquid Cooled Cable System	46
6.3) Adding Liquid Step	46
7.) Start Up	48
7.1) Verification and Inspection	48
7.2) Switch On	48
8.) Important Parameter Settings.....	51
8.1) Dispenser Parameter Setup	51
8.2 Power Cabinet Parameter Setup	55
8.3) Reset and Test	61
8.3.1) System Self Check.....	61
9.) Description of Relevant Parameters.....	62
10.) Power Distribution Strategy	64
10.1) Introduction to Power Nodes.....	64
10.2) Scenario 1: Increasing Charging Power	64
10.3) Scenario 2: Decreasing Charging Power.....	65
10.4) Scenario 3: Charging Initiated at Node Along the Power Path	67
11.) User Operation	69
11.1) Output Connector	69
11.1.1) CCS1 and NACS Connector	69
11.2) Operation Instructions	70
11.3) Ethernet and OCCP Setting	73
11.3.1) Connection Check	73
11.4) Network Setting	73
11.4.1) Router Set Up	73
11.4.2) Wireless Network Configuration	76
11.4.3) Wired Network Configuration	76
11.5) Charger Software Update.....	76
11.5.1) Upper Controller Update	76
11.5.2) Pilot Controller Update	78

Appendix 1) Engineering and Technical Parameters	79
Appendix 2) System Electrical Connection Diagram	82
Appendix 3) Maintenance	85
1.) Maintenance Table	85
2.) Maintenance Operation	85
2.1) AC Input Main Breaker	85
2.2) Devices and Connection Points	86
2.3) AC SPD	88
2.4) Charging Plug.....	88
2.5 Cooling Fan and Filter Cotton	89
2.6) ESD	90
2.7) Alarm Information.....	90
Appendix 4) Error Codes and Possible Solutions	91
Appendix 5) Torque Table.....	99

1.) IMPORTANT SAFETY INSTRUCTIONS

- Please read the operating instructions and notes carefully before starting operation to prevent accidents. The "Caution, Attention, Warning, and Danger" statements in the products and product manual do not represent all safety matters to be observed and are intended to supplement various operational safety precautions.
- During the various operations of our products and equipment, it is necessary to comply with the relevant National Safety Regulations and strictly observe the precautions and special safety instructions for the relevant equipment provided by InCharge Energy.
- Any usage of water on the charger during a charge session or during idling is a safety hazard and prohibited.

1.1) Electrical Safety

 Danger	<p>Since some parts of this power system are under high voltage during operation, direct or indirect contact can be fatal.</p>
---	--

- It is necessary to comply with the relevant National Safety Regulations during the installation of the Portable DC Charger. Personnel who install and maintain this equipment must be qualified to work with high DC voltage up to 1000Vdc and 3-phase AC voltage up to 600Vac.
- It is strictly forbidden to wear watches, bracelets, bangles, rings and other conductive objects on the wrist during installation and maintenance.
- If there is water inside the DC Charger enclosure, AC power and DC connector must be disconnected immediately. During operation in a humid environment, water should be strictly prevented from entering the equipment.
- During installation, it is strictly forbidden to operate the DC Charger and an "Operation prohibited" signboard must be used.

 Danger	<p>Construction operation of high voltage lines may cause fire or electric shock. The wiring area and the area where the line passes through for AC cables must comply with national and local regulations and norms. As this device utilizes high voltages do not attempt to install this equipment if you are not a qualified electrician.</p>
---	--

1.2) Tools

 Warning	<p>Special tools must be used during various operations involving high DC and AC voltages.</p>
--	--

1.3) Thunderstorm

 Danger	<p>It is strictly forbidden to carry out live installation and maintenance work during thunderstorms.</p>
---	---

- A strong electromagnetic field will be produced in the atmosphere during a thunderstorm. Therefore, the equipment should be well grounded to avoid damage to the equipment due to lightning strikes.

1.4) Static Electricity

 Caution	<p>Static electricity generated by the human body may damage electrostatic sensitive components on the circuit boards, such as the large-scale integrated circuit (IC), etc. Before handling any patch boards, circuit boards and IC chips, it is necessary to wear an anti-static wrist strap with the anti-static wrist strap wire connected to Ground to avoid damage to sensitive components due to static electricity.</p>
--	---

1.5) Short Circuit

 Danger	<p>During operation, it is strictly forbidden to short-circuit the positive and negative of the DC Charger DC distribution or short-circuit any DC distribution polarity to Ground. The DC Charger is a high voltage DC power supply, and a short circuit may cause damage to the DC Charger and personal safety hazards.</p>
---	---

- During work with High Voltage DC output, it is necessary to strictly check the polarity of cables and interface terminals.
- The space for DC power distribution work is compact and attention should be paid to planning cable routing etc. before starting any installation work.
- Insulated tools must be used.
- During live work, attention should be paid to keeping hands, arms, tools etc. away from live high voltage parts to avoid accidents.

1.6) Sharp Corners of Objects

 Warning	<p>During the handling of equipment by hand, it is necessary to wear protective gloves to prevent injuries caused by sharp objects.</p>
--	---

1.7) Power Cable

 Caution	<p>Make sure that the cable label is correct before the connection of cables.</p>
--	---

1.8) Signal Cables



Caution

Signal cables should be kept away from power cables, with a minimum distance of 100mm.

2.) General Product Description

The ICE-360/480 Split type-high power charger is specially designed for the Operator split and multi-EV charging point application with CCS/CHAdeMO/NACS standard. The Max output is 1000V/480kW when utilizing the 500A liquid cooled cable, and each charging connector can get max 480kW power.

The following ICE-360/480 split type eight connector, four dispenser system consists of one 480KW Power Cabinet (eight channels output) and four Charging Dispensers, including standard connector 125A(CHAdeMO)/200A(CCS&NACS)/300A(CCS&NACS) and liquid-cooled connector 500A(CCS&NACS).

2.1) Main Features

- The ICE-480 can fast charge all electric vehicles compliant with combined charging system (CCS) standards.
- IP55 for the Charging Dispenser and IP54 for the Power Cabinet with high protection and high reliability for harsh environment, -22°F ~ 122°F (-30°C~50°C) ambient temperature full power charging.
- Easily configure the output power up to 480kW and the output voltage up to 1000V.
- The battery charging state is displayed on the HMI and the charging cycle finishes by itself or can be interrupted by user command.
- The ICE-360/480 is user-friendly and safe. After user identification, it only requires coupling the charger's output plug in the EV for automatic starting if all safety features are accomplished.
- Full safety function with output contactor and fuse, ESD, SPD, leakage switch, insulation detector, and software logic for multiple protection.
- LAN and LTE wireless support, RFID authorization and Mobile App payment support.
- Optional CCS standard 500A liquid cooling charging connector in the Slim Line Dispenser
- Power transfer between the 8 connectors to improve the charging operation efficiency.
- User friendly interface with tempered glass protective 7" TFT capacitive touch screen LCD.

3.) General Characteristics

3.1) Technical Characteristics

The ICE-360/480 Split Power Cabinet and Dispenser technical characteristics are indicated in Table 3-1, Table 3-2, Table 3-3, Table 3-4, and Table 3-5. “N” means Natural cooling, “L” means Liquid cooling. The following is omitted:

Table 3-1: Power Cabinet (ICE-360/480) Technical Characteristics

Technical Data		Description	Remarks
Nominal Input	Phases/Lines	3 phases + P E (L1, L2, L3, + PE) WYE	
	Voltage	480/277 Vac (+/-10%)	
	Frequency	60Hz	
	Current	360: 2*228A 480: 2*304A	
	Power	360: 360kW 480: 480kW	
	Power factor	≥0.99	
	System efficiency	≥ 94.5% (Full load)	
DC Output	Max power	360kW 300~1000V 480kW 300~1000V	
	Voltage range	150 ~ 1000Vdc	
	Current	8-outputs: Each output Max 500A	
	Dispenser support	4 slim line dispensers / 8 charging connectors connection	
Auxiliary power Output	Voltage	480Vac	
	Current	8A	
Cabinet	Dimensions(W*D*H)	39.4*31.5*78.7 in (1000*800*2000 (mm))	
	Weight	1025.15 lbs. [465 kg (excluding power module, power module is 49.6 lbs. (22.5kg))]	
	Protection Degree	NEMA 3R/IP54	
Environmental conditions	Operating temperature ¹	-13°F ~ +122°F (-25°C ~ +50°C)	
	Transportation/storage temperature	-40°F ~ +158°F (-40°C ~ +70°C)	
	humidity	5%RH ~ 95%RH	
	Place of installation	Indoor / Outdoor	
	Altitude	6561 ft (2000m)	
	Sound Noise	≤75dB (nominal input/output power, the environment temperature is 77°F / 25°C.)	
	Atmospheric pressure	80KPa ~ 110Kpa (11.6 psi – 16.0 psi)	
	AC Input Overvoltage category	III	
	DC Output Overvoltage category	I	
	Protection class	Class I	
<p style="color: red;">Note 1: The Charging Dispenser provides full output power up to 122°F (50°C), output power derating 5% / °C above 122°F (50°C).</p>			

Table 3-2: Dispenser A (EXP500-LCD-UU2) Technical Characteristics

Technical Data		Description	Remarks
Nominal Input	Phases/Lines	(DC1+, DC1-) + (DC2+, DC2-) + PE	
	Voltage Range	Max 1000Vdc	
	Current	500A, 200A	
	Power	500kW, 200kW	
	System Efficiency	≥ 99% (Full load)	
DC Output CCS1(L)	Voltage	150 ~ 1000Vdc	
	Current	500A(L)	
	Nominal Power	500kW	
DC Output CCS1	Voltage	150 ~ 1000Vdc	
	Current	200A(N),	
	Nominal power	200kW	
Auxiliary Power Input	Voltage	480Vac	
	Current	1.2A	
Cabinet	Dimensions(W*D*H)	19.7*10.23*70.86 in (500*260*1800 (mm))	
	Weight	430 lbs. (195kg)	
	Protection Degree	IP55	
HMI and Command Unit	Local Interface	TFT Color touch display 7"	
	Communication	CAN, LAN	
	Protocol	OCPP1.6 specification	
Environmental Conditions	Operating Temperature ¹	-13°F ~ +122°F (-25°C ~ +50°C)	
	Transportation/Storage Temperature	-40°F ~ +158°F (-40°C ~ +70°C)	
	Humidity	5%RH ~ 95%RH	
	Place of Installation	Indoor / Outdoor ²	
	Altitude	6561.7 ft (2000m)	
	Sound Noise	≤60dB (nominal input/output power, the environment temperature is 77°F / 25°C.)	
	Atmospheric Pressure	80KPa ~ 110Kpa (11.6 psi – 16.0 psi)	
	Overvoltage Category	II	
Protection Class	Class I		
<p>Note 1: The Charging Dispenser provides full output power up to 122°F (50°C), output power derating 5% / °C above 122°F (50°C).</p>			
<p>Note 2: The protection degree of the Charging Dispenser is IP55. But for charging safety it should not be used during rain or snow if water can reach the charger connector.</p>			

Table 3-3: Dispenser B (EXP300-FDC-UU2) Technical Characteristics

Technical Data		Description	Remarks
Nominal Input	Phases/Lines	(DC1+, DC1-) +(DC2+, DC2-) + PE	
	Voltage Range	Max 1000Vdc	
	Current	300A	
	Power	300kW	
	System Efficiency	≥ 99% (Full load)	
DC Output CCS1	Voltage	150 ~ 1000Vdc	
	Current	300A	
	Nominal Power	300kW	
Auxiliary Power Input	Voltage	480Vdc	
	Current	0.6A	
Cabinet	Dimensions(W*D*H)	19.7*10.23*70.86 in (500*260*1800 (mm))	
	Weight	407.9 lbs. (185kg)	
	Protection Degree	IP55	
HMI and Command Unit	Local Interface	TFT Color touch display 7"	
	Communication	CAN, LAN	
	Protocol	OCP1.6 specification	
Environmental Conditions	Operating Temperature ¹	-13°F ~ +122°F (-25°C~+50°C)	
	Transportation/Storage Temperature	-40°F ~ +158°F (-40°C~+70°C)	
	humidity	5%RH ~ 95%RH	
	Place of Installation	Indoor / Outdoor ²	
	Altitude	6561.7 ft (2000m)	
	Sound Noise	≤60dB (nominal input/output power, the environment temperature is 77°F / 25°C.)	
	Atmospheric Pressure	80KPa ~ 110Kpa (11.6 psi – 16.0 psi)	
	Overvoltage Category	II	
Protection Class	Class I		
<p>Note 1: The Charging Dispenser provides full output power up to 122°F (50°C), output power derating 5% / °C above 122°F (50°C).</p>			
<p>Note 2: The protection degree of the Charging Dispenser is IP55. But for charging safety it should not be used during rain or snow if water can reach the charger connector.</p>			

Table 3-4: Dispenser C (EXP200-FDC-UU2) Technical Characteristics

Technical Data		Description	Remarks
Nominal Input	Phases/Lines	(DC1+, DC1-) + (DC2+, DC2-) + PE	
	Voltage Range	Max 1000Vdc	
	Current	200A	
	Power	200kW	
	System Efficiency	≥ 99% (Full load)	
DC Output CCS1	Voltage	150~1000Vdc	
	Current	200A	
	Nominal Power	200kW	
Auxiliary Power Input	Voltage	480Vdc	
	Current	0.6A	
Cabinet	Dimensions(W*D*H)	19.7*10.23*70.86 in (500*260*1800 (mm))	
	Weight	407.85 lbs. (185kg)	
	Protection Degree	IP55	
HMI and Command Unit	Local Interface	TFT Color touch display 7"	
	Communication	CAN, LAN	
	Protocol	OCPP1.6 specification	
Environmental Conditions	Operating Temperature ¹	-13°F ~ +122°F (-25°C ~ +50°C)	
	Transportation/Storage Temperature	-40°F ~ +185°F (-40°C ~ +70°C)	
	humidity	5%RH ~ 95%RH	
	Place of Installation	Indoor / Outdoor ²	
	Altitude	6561.68 ft (2000m)	
	Sound Noise	≤60dB (nominal input/output power, the environment temperature is (77 F) 25°C.)	
	Atmospheric Pressure	80KPa ~ 110Kpa (11.6 psi – 16.0 psi)	
	Overvoltage Category	II	
	Protection Class	Class I	
<p>Note 1: The Charging Dispenser provides full output power up to 122°F (50°C), output power derating 5% / °C above 122°F (50°C).</p>			
<p>Note 2: The protection degree of the Charging Dispenser is IP55. But for charging safety it should not be used during rain or snow if water can reach the charger connector.</p>			

Table 3-5: Dispenser D (EXP200-FDC-UC2) Technical Characteristics

Technical Data		Description	Remarks
Nominal Input	Phases/Lines	(DC1+, DC1-) +(DC2+, DC2-) + PE	
	Voltage Range	Max 1000Vdc ,500Vdc	
	Current	200A, 125A	
	Power	200kW ,62.5kW	
	System Efficiency	≥ 99% (Full load)	
DC Output CCS1	Voltage	150 ~ 1000Vdc	
	Current	200A	
	Nominal Power	200kW	
DC Output CHAdEMO	Voltage	150 ~ 500Vdc	
	Current	125A	
	Nominal Power	62.5kW	
Auxiliary Power Input	Voltage	480Vdc	
	Current	0.6A	
Cabinet	Dimensions(W*D*H)	19.7*10.23*70.86 in (500*260*1800 (mm))	
	Weight	407.85 lbs. (185kg)	
	Protection Degree	IP55	
HMI and Command Unit	Local Interface	TFT Color touch display 7"	
	Communication	CAN, LAN	
	Protocol	OCPP1.6 specification	
Environmental Conditions	Operating Temperature ¹	-13°F ~ +122°F (-25°C ~ +50°C)	
	Transportation/Storage Temperature	-40°F ~ +185°F (-40°C ~ +70°C)	
	humidity	5%RH ~ 95%RH	
	Place of Installation	Indoor / Outdoor ²	
	Altitude	6561.68 ft (2000m)	
	Sound Noise	≤60dB (nominal input/output power, the environment temperature is 77° (25°C)).	
	Atmospheric Pressure	80KPa ~ 110Kpa (11.6 psi – 16.0 psi)	
	Overvoltage Category	II	
Protection Class	Class I		
<p>Note 1: The Charging Dispenser provides full output power up to 122 F (50°C), output power derating 5% / °C above 122 F (50°C).</p>			
<p>Note 2: The protection degree of the Charging Dispenser is IP55. But for charging safety it should not be used during rain or snow if water can reach the charger connector.</p>			

Table 3-6 Overhead Charging Dispenser E (EXP400-FSW-U2) Technical Characteristics

Technical Data		Description	Remarks
Nominal Input	Phases/Lines	(DC+,DC-) +PE	
	Voltage Range	Max 1000Vdc	
	Current	400A	
	Power	400kW	
	System Efficiency	≥ 99% (Full load)	
DC Output CCS2	Voltage	150~1000Vdc	
	Current	400A	
	Nominal Power	400kW	
Auxiliary Power Input	Voltage	480Vac	
	Current	0.6A	
Cabinet	Dimensions(W*D*H)	30.04in x 9.45in x 16.34in (763*240*415 mm)	
	Weight	110lbs (50kg)	
	Protection Degree	IP65	
Command Unit	Local Interface	Status LED	
	Communication	CAN/Ethernet	
Environmental Conditions	Operating Temperature ¹	-22°F ~ +122°F (-30°C~+50°C)	
	Transportation/Storage Temperature	-40°F ~ +158°F (-40°C~+70°C)	
	humidity	5%RH~95%RH	
	Place of Installation	Indoor / Outdoor ²	
	Altitude	6561.68ft (2000m)	
	Sound Noise	≤55dB (nominal input/output power, the environment temperature is 25°C.)	
	Atmospheric Pressure	80KPa~110KPa	
	Overvoltage Category	III	
	Protection Class	Class I	
<p>Note 1: The Charging Dispenser provides full output power up to 50°C, output power derating 5% / °C above 50°C.</p>			
<p>Note 2: The protection degree of the Charging Dispenser is IP55. But for charging safety it should not be used during rain or snow if water can reach the charger connector.</p>			

Table 3-7 Overhead Charging Dispenser F (EXP300-FSW-U2) Technical Characteristics

Technical Data		Description	Remarks
Nominal Input	Phases/Lines	(DC1+,DC1-)+PE	
	Voltage Range	Max 1000Vdc	
	Current	300A	
	Power	300kW	
	System Efficiency	≥ 99% (Full load)	
DC Output CCS1	Voltage	150~1000Vdc	
	Current	300A	
	Nominal power	300kW	
Auxiliary Power Input	Voltage	480Vac	
	Current	0.6A	
Cabinet	Dimensions(W*D*H)	30.04in x 9.45in x 16.34in (763*240*415 mm)	
	Weight	105.8lbs (48kg)	
	Protection Degree	IP65	
Command Unit	Local Interface	Status LED	
	Communication	CAN/Ethernet	
Environmental Conditions	Operating Temperature ¹	-22°F ~ +122°F (-30°C~+50°C)	
	Transportation/Storage Temperature	-40°F ~ +158°F (-40°C~+70°C)	
	Humidity	5%RH~95%RH	
	Place of Installation	Indoor / Outdoor ²	
	Altitude	6561.68ft (2000m)	
	Sound Noise	≤55dB (nominal input/output power, the environment temperature is 25°C.)	
	Atmospheric Pressure	80KPa~110KPa	
	Overtoltage Category	III	
	Protection Class	Class I	
<p>Note 1: The Charging Dispenser provides full output power up to 50°C, output power derating 5% / °C above 50°C.</p>			
<p>Note 2: The protection degree of the Charging Dispenser is IP55. But for charging safety it should not be used during rain or snow if water can reach the charger connector.</p>			

Table 3-8 Overhead Charging Dispenser G (EXP200-FSW-U2) Technical Characteristics

Technical Data		Description	Remarks
Nominal Input	Phases/Lines	(DC1+,DC1-)+PE	
	Voltage Range	Max 1000Vdc	
	Current	200A	
	Power	200kW	
	System Efficiency	≥ 99% (Full load)	
DC Output CCS1	Voltage	150~1000Vdc	
	Current	200A	
	Nominal Power	200kW	
Auxiliary Power Input	Voltage	480Vac	
	Current	0.6A	
Cabinet	Dimensions(W*D*H)	30.04in x 9.45in x 16.34in (763*240*415 mm)	
	Weight	97lbs (44kg)	
	Protection Degree	IP65	
Command Unit	Communication	CAN,LAN	
	Communication	CAN/Ethernet	
Environmental Conditions	Operating Temperature ¹	-22°F ~ +122°F (-30°C~+50°C)	
	Transportation/Storage Temperature	-40°F ~ +158°F (-40°C~+70°C)	
	humidity	5%RH~95%RH	
	Place of Installation	Indoor / Outdoor ²	
	Altitude	6561.68ft (2000m)	
	Sound Noise	≤55dB (nominal input/output power, the environment temperature is 25°C.)	
	Atmospheric Pressure	80KPa~110KPa	
	Overvoltage Category	III	
	Protection Class	Class I	
<p>Note 1: The Charging Dispenser provides full output power up to 50°C, output power derating 5% / °C above 50°C.</p>			
<p>Note 2: The protection degree of the Charging Dispenser is IP55. But for charging safety it should not be used during rain or snow if water can reach the charger connector.</p>			

3.2) Model Description

Table 3-9: ICE-360/480 System Models

Model	Configuration	Remarks
ICE-480-FER5-2	8 charging connectors connection	480kW
ICE-360-FER5-2	8 charging connectors connection	360kW
IDC500-LDC-UU2	CCS1(L)+CCS1	500kW+200kW
IDC300-FDC-UU2	CCS1+CCS1	300kW+300kW
IDC200-FDC-UU2	CCS1+CCS1	200kW+200kW
IDC200-FDC-UC2	CCS1+CHAdeMO	200kW+200kW
IDC400-FSW-U2	CCS1	400kW
IDC300-FSW-U2	CCS1	300kW
IDC200-FSW-U2	CCS1	200kW

- The ICE-360/480 System supports multiple terminal combinations.
- For all non-standardized combinations, please refer to the InCharge Energy Spec Sheet for the ICE-360/480 Split System

3.3) Standards

The ICE-360/480 Split DC Charger complies with the following standards:

- **IEC 61851-1 2017:** Electric vehicle conductive charging system. Part 1: General Requirements
- **IEC 61851-23 2014:** Electric vehicle conductive charging system - Part 23: DC electric vehicle charging station
- **IEC 61851-24 2014:** Electric vehicle conductive charging system - Part 24: Digital communication between a DC EV charging station and an electric vehicle for control of DC charging
- **EN 61851-1 2019:** Electric vehicle conductive charging system. Part 1: General Requirements
- **EN 61851-23 2014:** Electric vehicle conductive charging system - Part 23: DC electric vehicle charging station
- **EN 61851-24 2014:** Electric vehicle conductive charging system - Part 24: Digital communication between a DC EV charging station and an electric vehicle for control of DC charging
- **UL 2202:** Standard for Safety for Electric Vehicle (EV) Charging System Equipment
- **CSA 22.2:** Power Conversion Equipment

4.) Product Parts Presentation

The ICE-360/480 Split DC Charging System is composed of Power Cabinet and Charging Dispensers. The System can be installed indoors or outdoors. However, when installed outdoors and used during inclement weather (snow/rain), caution should be used when performing charging as water can reach the charging connector.

The ICE-360/480 separate DC charging system series of fast DC chargers have various possible output combinations, as shown in Figures 4.1, 4.2, and 4.3:



Figure 4.1 External View (Such as 8 connector and 4 Slimline Dispenser system)

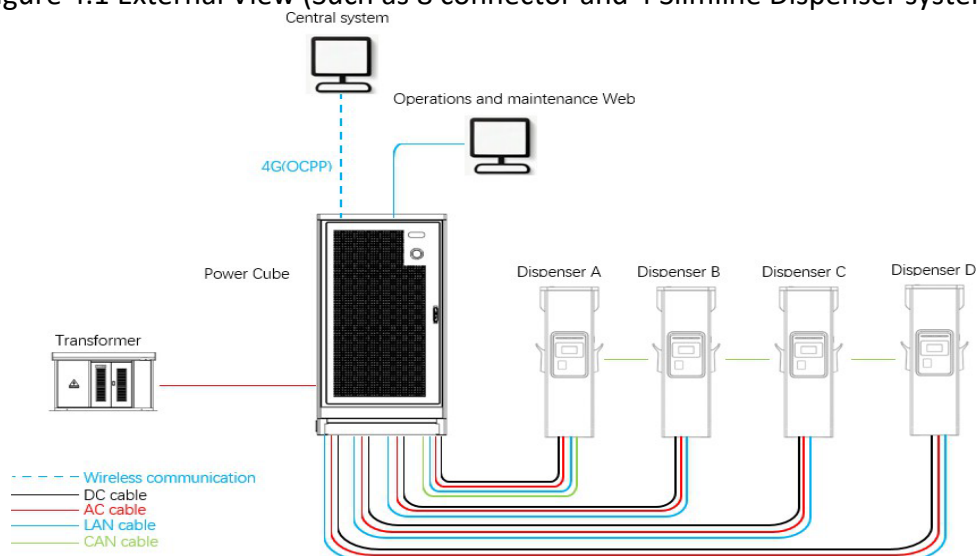

Figure 4.2 system Connection Diagram with all Slim Line Dispenser

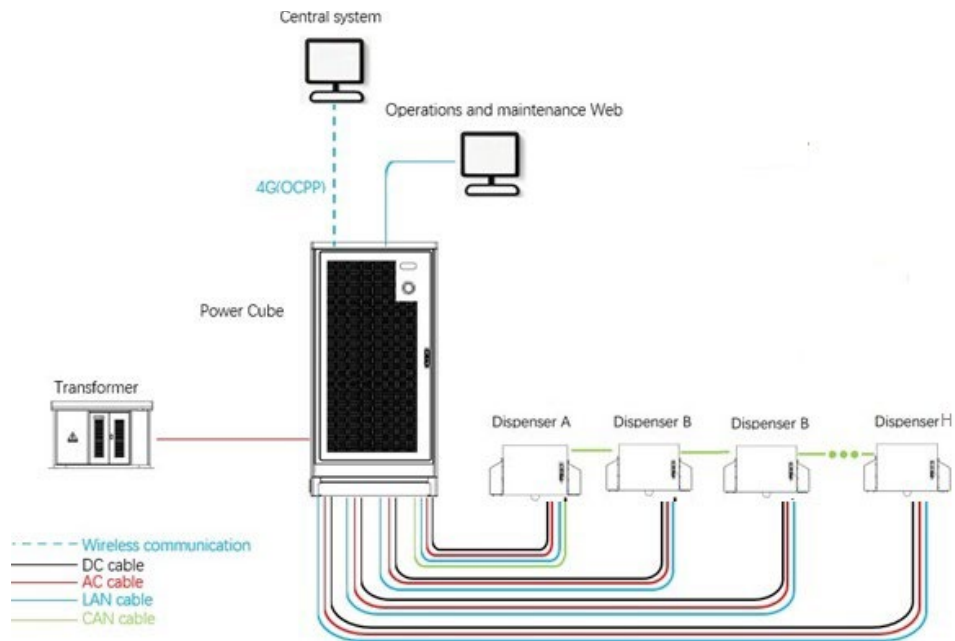

Figure 4.3 System Connection Diagram with All Micro Dispenser

5.) Installation

5.1) Safety and Compliance

The working voltage and current inside the charging system is very high. The following rules should always be observed to ensure personal safety:

- Only personnel who have received training for and fully mastered the knowledge of the charging system can complete installation. During installation, always observe the safety precautions mentioned in this document and all relevant National Safety Regulations.
- It is necessary to make sure that the charging system DC output is disconnected in case of operation inside the charging system. The main inputs of the charging system must also be disconnected.

5.2) Grounding Instructions

An equipment grounding conductor, or a grounded, metal, and permanent wiring system is required for the ICE-360/480 charger connection. This should be run with circuit conductors and connected to the equipment grounding bar or lead on the ICE-360/480 charger.

5.3) Unboxing and Visual Inspection

- Check if the exterior packaging has been damaged by mechanical impacts or any accidents during transportation.
- If applicable, check that the exterior panels of the ICE-360/480 are without fault.
- Check if the interior of the Quick Charger Station is clean.
- Check if the door of the Quick Charger Station is working properly.
- Check for a proper Quick Charger Station protective ground connection point, which should be interconnected with the low voltage switchboard ground connection during the installation.

5.4) Assembly/Placing Instructions

- As shown in Figures 5.2 and 5.3, the concrete foundation should be made, and the height of the base should not be less than 7.9 in (200 mm).
- It is recommended to reserve a Φ 90 plastic pipe at the cable entrance, and the height of the pipe extending out of the foundation horizontal plane shall not be more than 3.15 in (80mm).
- As shown in Figure 5.2, mark the installation holes of four M12 expansion bolts on the concrete foundation.
- Drill 4 holes on the concrete foundation, select the hammer drill bit of Φ 16mm type, and use the percussion drill to drill the holes perpendicular to the ground at the above marked hole position, with the drilling depth of 2.36 ~ 3.15 in (60mm ~ 80mm).

- Use four M12 × 60 expansion bolts equipped with attached accessories, slightly tighten the bolts, vertically put them into the hole, and knock them with a rubber hammer until all the expansion pipes enter the installation hole.
- Screw off the bolt, spring pad and flat pad in turn counterclockwise.

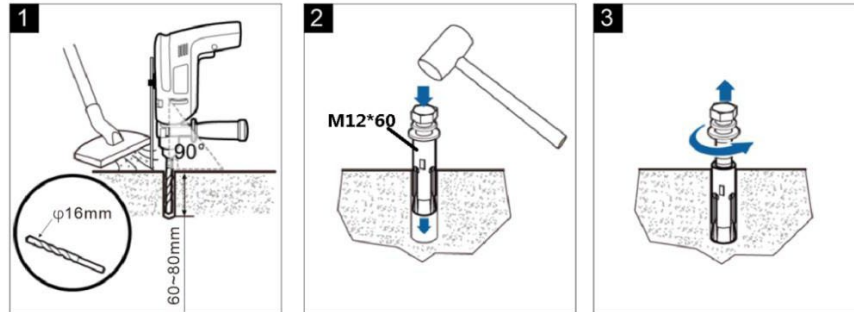
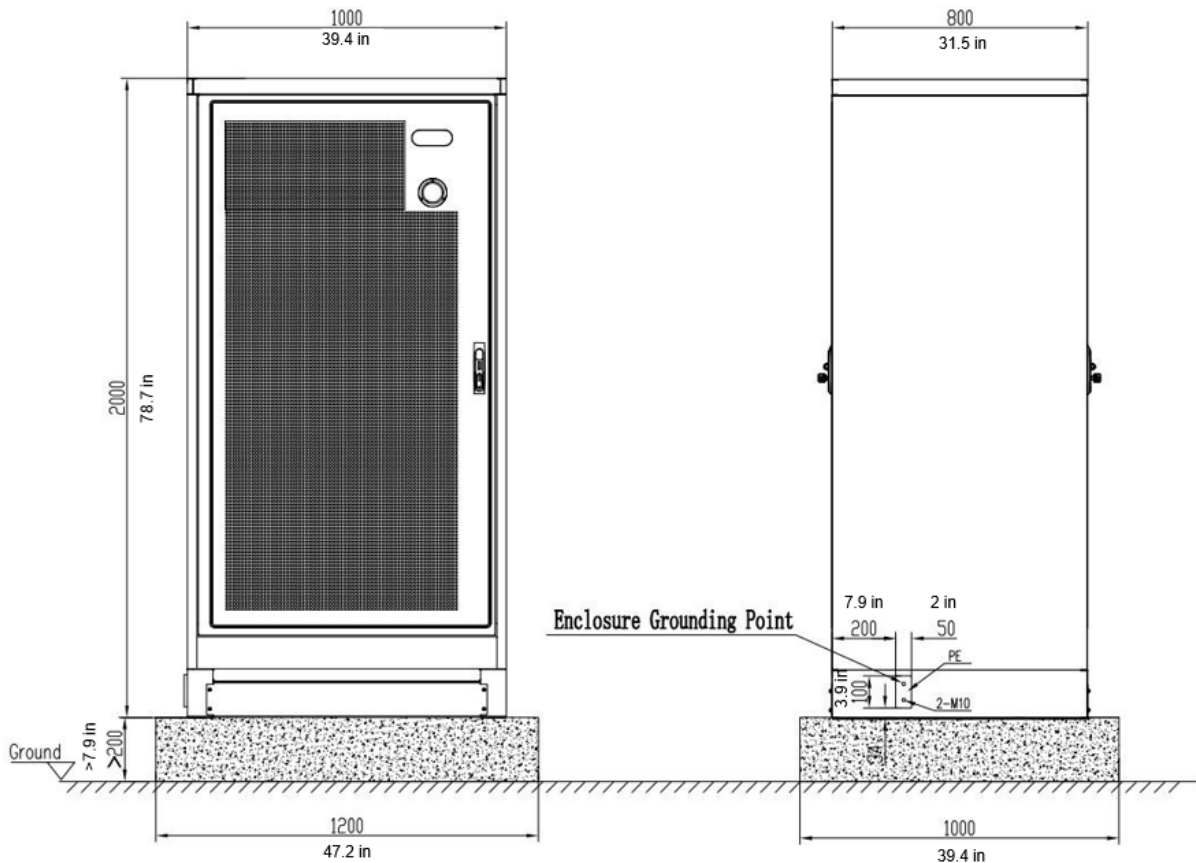

Figure 5.1 Expansion Bolt Fixing of Concrete Foundation

5.4.1) Preparation of Concrete Foundation



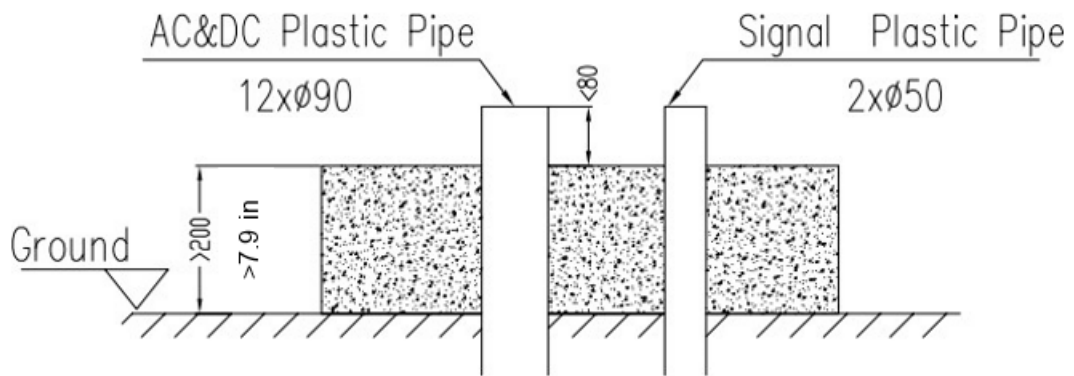
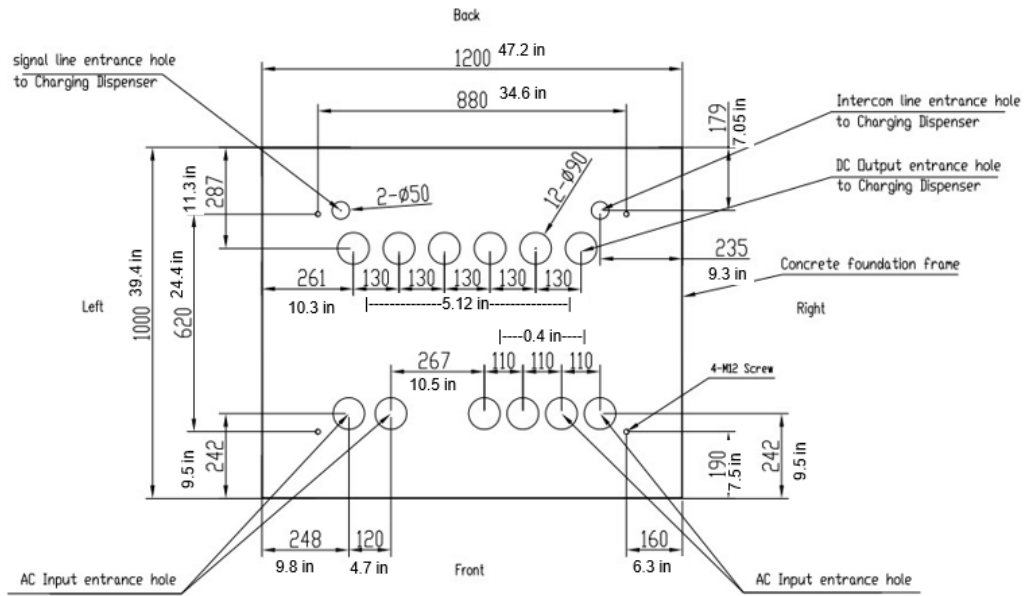

Figure 5.2 Power Cabinet Concrete Foundation View

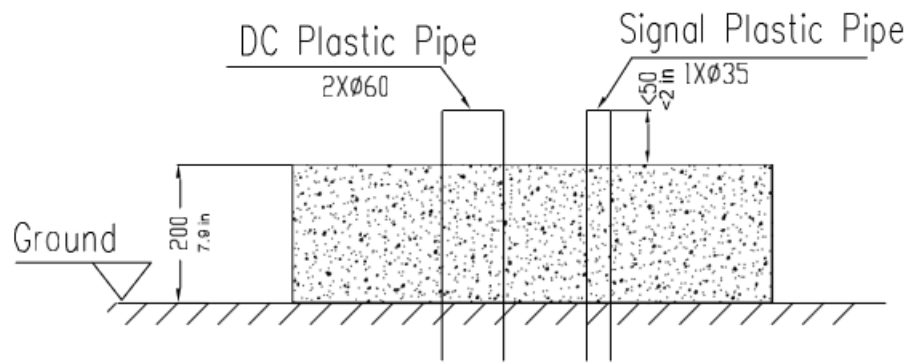

Figure 5.3 Charging Dispenser Concrete Foundation View

5.4.2) Power Cabinet Installation

- The protective covers on both sides of the steel base of the cabinet can be removed, and the cabinet can be transported to the concrete foundation by forklift.
- Align the installation hole of the cabinet base and fix the cabinet on the concrete foundation with M12*60 expansion bolts at a torque value of 28.40 ft-lbs

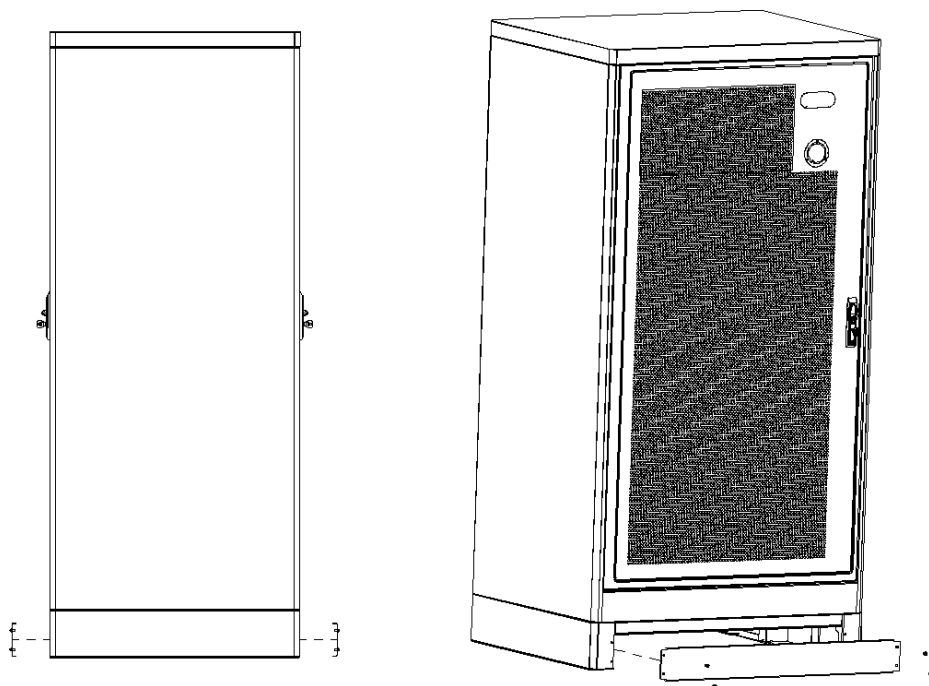

Figure 5.4 Power Cabinet Installation View

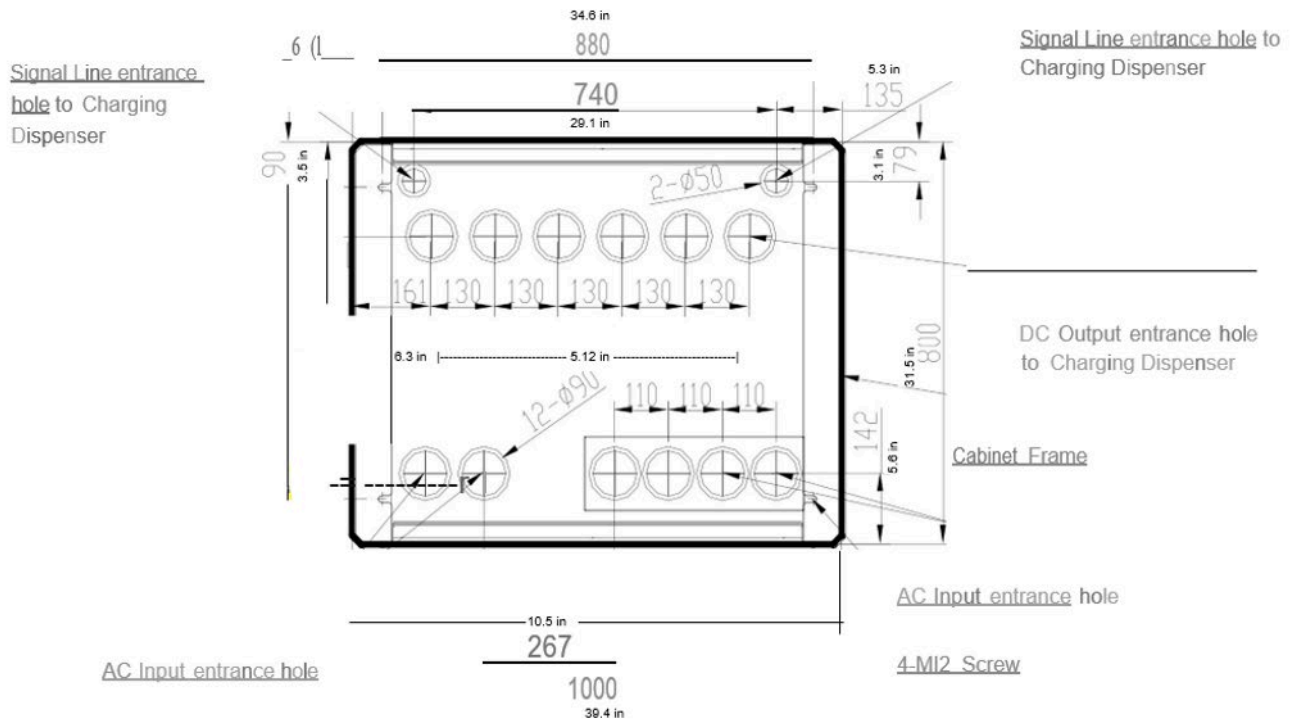

Figure 5.5 Power Cabinet Top View

5.4.3) Slim Line Dispenser Installation

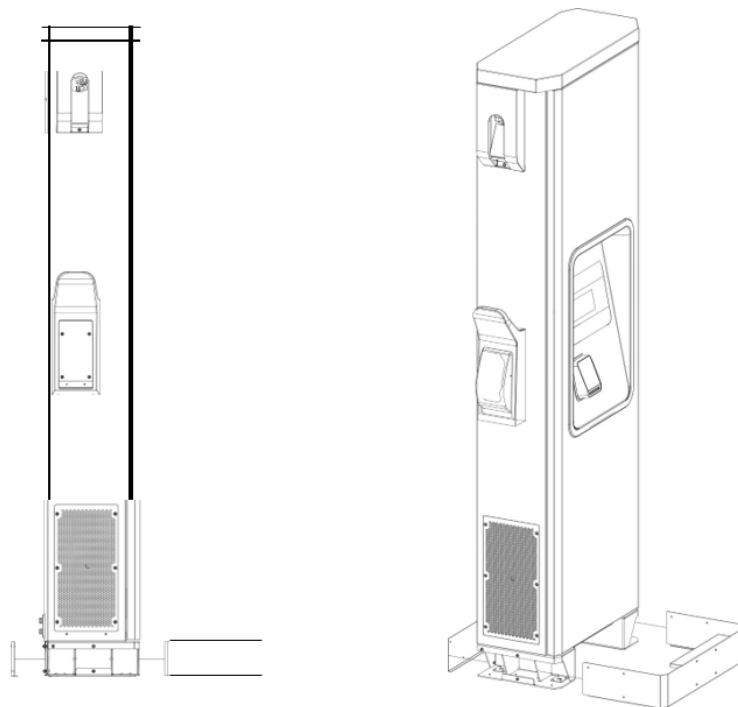

Figure 5.6 Charging Dispenser Installation View

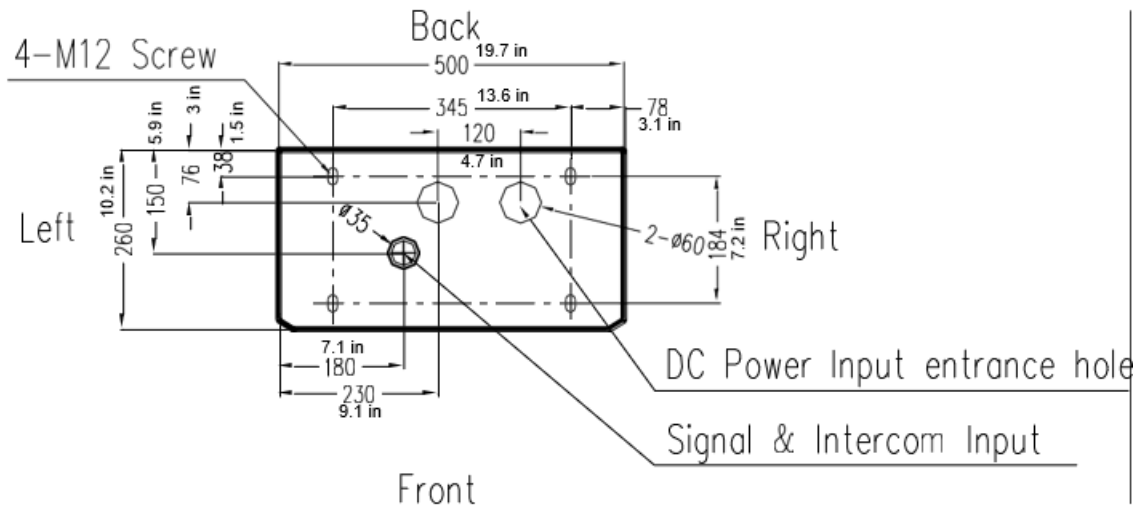

Figure 5.7 Charging Dispenser Top View

5.4.4) Micro Dispenser Installation (Wall/Overhead)

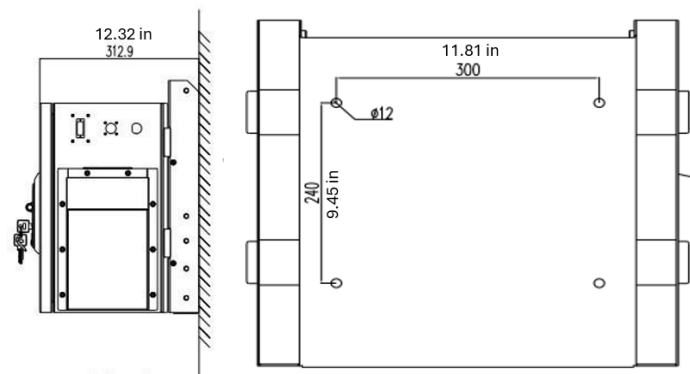

Figure 5.8 Micro Dispenser Mounted on Wall

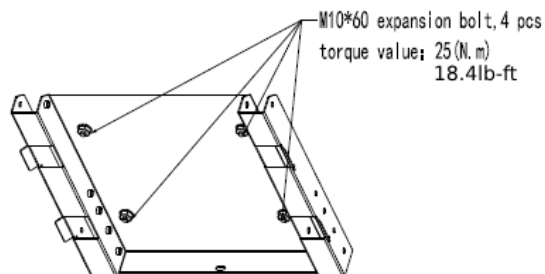

Figure 5.8.1 Micro Dispenser Wall Mount Bracket

- Drill holes into the wall based on the dimensions of the bracket shown in figure 5.8. Secure the bracket onto the wall with four M10*60 bolts and torque them down to the specified value.

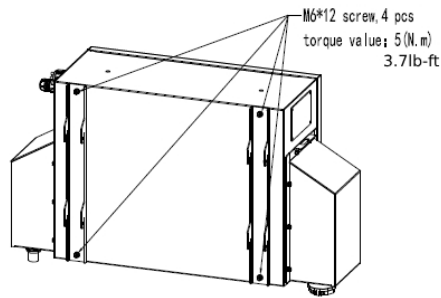

Figure 5.8.2 Micro Dispenser adapter brackets

- Secure the two brackets onto the back of the Micro Dispenser utilizing four M6*12 bolts.

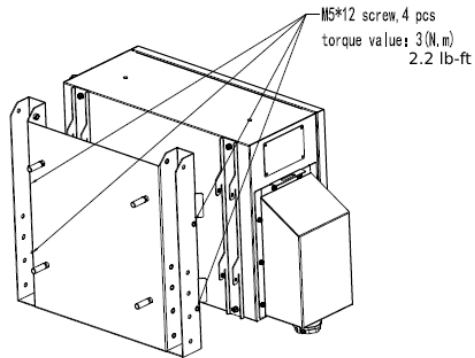

Figure 5.8.3 Micro Dispenser attachment

- Lift and place the micro dispenser onto the wall mount bracket. Once placed, secure in place with four M5*12 bolts.

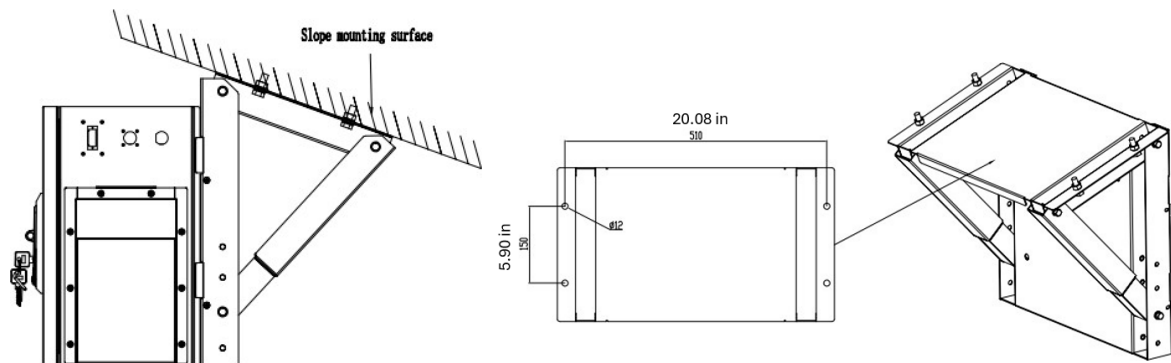

Figure 5.9 Dispenser Mounted on A Steel Frame or Gantry

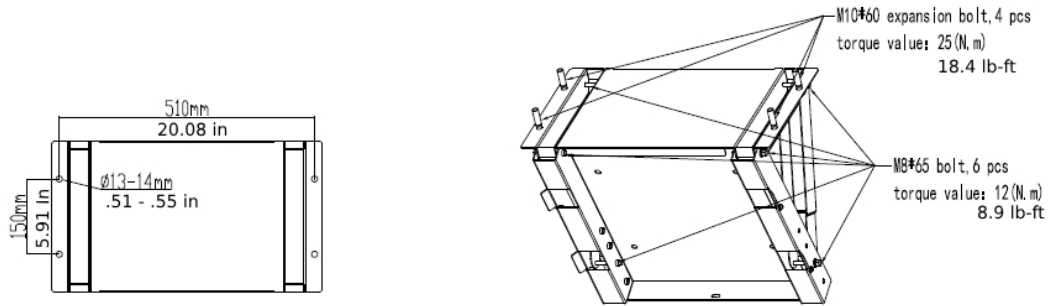

Figure 5.9.1 Micro Dispenser Gantry Mount Bracket

- Drill holes into the wall based on the dimensions of the bracket shown in figure 5.9. Secure the bracket onto the wall with four M10*60 bolts and torque them down to the specified value.

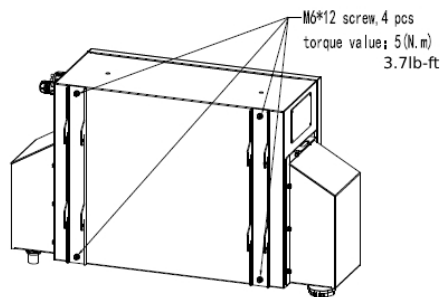

Figure 5.9.2 Micro Dispenser adapter brackets

- Secure the two brackets onto the back of the Micro Dispenser utilizing four M6*12 bolts.

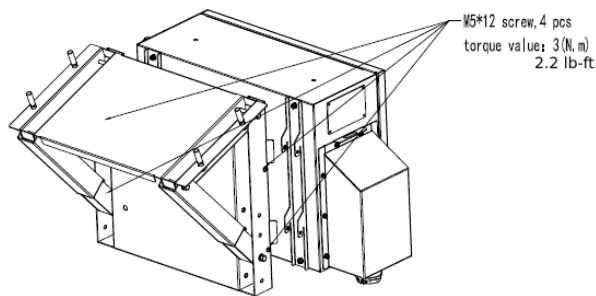

Figure 5.10 Micro Dispenser Gantry Mount

- Installation on angled overhead support : As shown in the figure 5.11 : Firstly, combined with the slope of the parking gantry, adjust the installation support angle so that the installed terminal is perpendicular to the ground. (Installation supports four angle adjustments: 0 ° , 10 ° , 20 ° , and 30 ° , to adapt to different gantry slopes). Then, use the combination bolts to install the Installing support in the corresponding position on the

Parking sheet. Simultaneously install the Cabinet wall pendant on the charging dispenser. Finally, affix the charging dispenser onto the Installing Support.

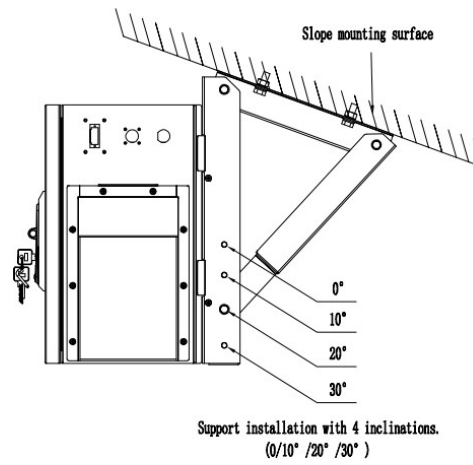

Figure 5.11 Diagram of Adjustment Angle of The Installation Plate

5.4.5) Power and Signal Cable Connections

Notes: System cable connection see Appendix 3 for the electrical connection of the 480kW split system. The communication distance between the system cabinets shall be less than 50m.

5.4.5.1) Connection Power Cabinet AC Input Cable

- Power Cabinet AC input wiring: two sets of AC input, using four-core cables, 3 phases + protective grounding as shown in Figure 5.12

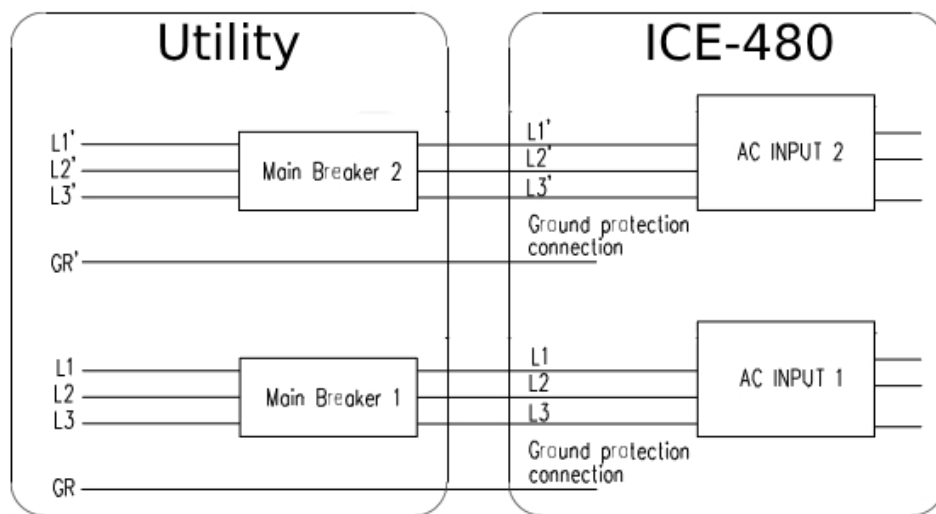

Figure 5.12 Power Cabinet AC Input Cable

Note:

- Neutral Wiring is Optional and not Required**

Table 5-1 Selection of AC Input Cable for Power Cabinet

NO.	The section for AC feed cables	Amperage at 480Vac	Max. Power of charger	Specification of terminal screw	Reserved length inside cabinet	Wiring diagram
1	(AC INPUT1) 3*0.3in2 + 0.15in2 (3*185mm2 + 1*95mm2)	304A	480kW	L1/L2/L3/ is M10 PE is M8	23.6 in 0.6m	Figure 5.13
	(AC INPUT2) 3*0.3in2 + 0.15in2 3*185mm2+1*95mm2	304A		L1/L2/L3/ is M10 PE is M8	23.6 in 0.6m	
2	(AC INPUT 1) 2/0 AWG	228A	360kW	L1/L2/L3/ is M10 PE is M8	23.6 in 0.6m	
	(AC INPUT 2) 2/0 AWG	228A		L1/L2/L3/ is M10 PE is M8	23.6 in 0.6m	
<p><i>Aluminum conductors may be used in place of copper conductors. Ensure to properly size and install per National Electrical Code/Local Codes</i></p>						

Notes:

- The AC feed power cables should be no less than 90°C (194 F) temperature resistant grade.
- The protective MCCB must be installed on the customer's distribution cabinet, and the upper MCCB capacity shall not be less than 1.25 times the input current.
- It is recommended that the upper MCCB should not be equipped with RCD function.
- This system is to be connected to a grounded, metal, permanent wiring system; or an equipment-grounding conductor is to be run with circuit conductors and connected to equipment-grounding terminal or lead on battery charger.
- **Before electrical connection, all switches shall be placed in the OFF position.**

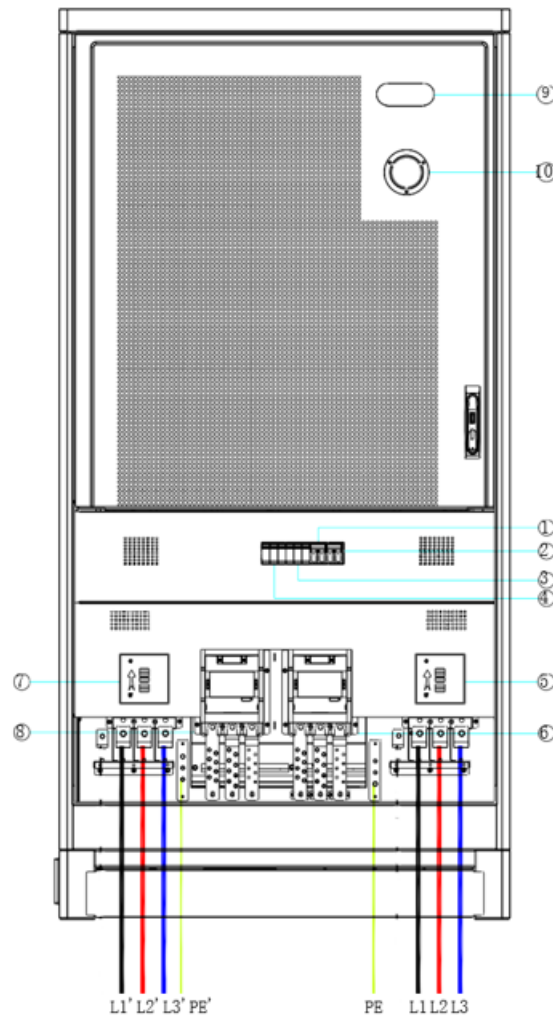

①	4QFP	Auxiliary Power for Power Cabinet
②	3QFP	Auxiliary Power for Dispenser
③	1SPD	AC SPD
④	2SPD	AC SPD
⑤	1QF	AC Input MCCB
⑥	1KMA	Main contactor
⑦	2QF	AC Input MCCB
⑧	2KMA	Main contactor
⑨	LED	Light emitting diode
⑩	ESD	Emergency Shutdown Device

Figure 5.13 Power Cabinet AC Input

5.4.5.2 Connection of Power Cables

- It is recommended to select the connection cable between the Power Cube and the Dispensers according to the requirements in Table 5-2. Connect the power cable between the power Cabinet and the Dispenser as shown in the following diagram 5.14 and diagrams 5.15 and 5.16.

Table 5-2 Selection of Cables from Power Cabinet to Dispenser

NO	Name of Connector	The section for DC feed cables	Amperage	Specification of terminal screw	Reserved length Power Cabinet	Reserved length Dispenser	Wiring diagram
1	Dispenser A DC Input	2*0.37 in2(240mm2)	500A,1000V	(DC1+, DC1-) is M10	1m (39.37 in)	43.31 in (1.1m)	Figure 5.14 or 5.15
2		2*0.11 in2 (70mm2)	200A,1000V	(DC2+, DC2-) is M10	1m (39.37 in)	43.31 in (1.1m)	
3		0.78 in2 (50mm2)	/	PE is M8	0.5m (19.68 in)	43.31 in (1.1m)	
4	Dispenser B DC Input	2*0.15 in2 (95mm2)	300A,1000V	(DC1+, DC1-) is M10	1m (39.37 in)	43.31 in (1.1m)	Figure 5.14 or 5.15
5		2*0.15 in2 (95mm2)	300A,1000V	(DC2+, DC2-) is M10	1m (39.37 in)	43.31 in (1.1m)	
6		0.78 in2 (50mm2)	/	PE is M8	0.5m (19.68 in)	43.31 in (1.1m)	
7	Dispenser C DC Input	2*0.11 in2 (70mm2)	200A,1000V	(DC5+, DC5-) is M10	1m (39.37 in)	43.31 in (1.1m)	Figure 5.14 or 4.15
8		2*0.11 in2 (70mm2)	200A,1000V	(DC6+, DC6-) is M10	1m (39.37 in)	43.31 in (1.1m)	
9		0.78 in2 (50mm2)	/	PE is M8	0.5m (19.68 in)	43.31 in (1.1m)	
10	Dispenser D DC Input	2*0.11 in2 (70mm2)	200A,1000V	(DC1+, DC1-) is M10	1m (39.37 in)	43.31 in (1.1m)	Figure 5.14 or 5.15
11		2* 0.78 in2 (50mm2)	125A,500V	(DC2+, DC2-) is M10	1m (39.37 in)	43.31 in (1.1m)	
12		0.78 in2 (50mm2)	/	PE is M8	0.5m (19.68 in)	43.31 in (1.1m)	
13	Dispenser E DC Input	2*120mm2	400A,1000V	(DC1+,DC1-)is M10	1m	1.1m	Figure 5.16
14	50mm2	/	PE is M8	0.5m	1.1m		
15	Dispenser F DC Input	2*95mm2	300A,1000V	(DC1+,DC1-)is M10	1m	1.1m	Figure 5.16
16	50mm2	/	PE is M8	0.5m	1.1m		
17	Dispenser G DC Input	2*70mm2	200A,1000V	(DC1+,DC1-)is M10	1m	1.1m	Figure 5.16
18	50mm2	/	PE is M8	0.5m	1.1m		
19	Auxiliary power input of Charging Dispenser	2*0.0038 in2 (2.5mm2)	1.2A,480V	L1/L2 is E2510	1m (39.37 in)	1m (39.37 in)	Figure 5.17, 5.18, 5.21, or 5.24
20	Can communication cable	UL2464 22AWG 2C With shielding	/	CANH/CANL is E0510	1m (39.37 in)	1m (39.37 in)	Figure 5.17, 5.18, 5.20 or 5.22

21	LAN communication of Charging Dispenser	2*CAT6 shielded network cable	/	Upper and Pilot controller LAN is RJ45	3m (118.11 in)	78.74 in (2m)	Figure 5.17, 5.18, 5.19 or 5.23
----	---	-------------------------------	---	--	----------------	---------------	---------------------------------

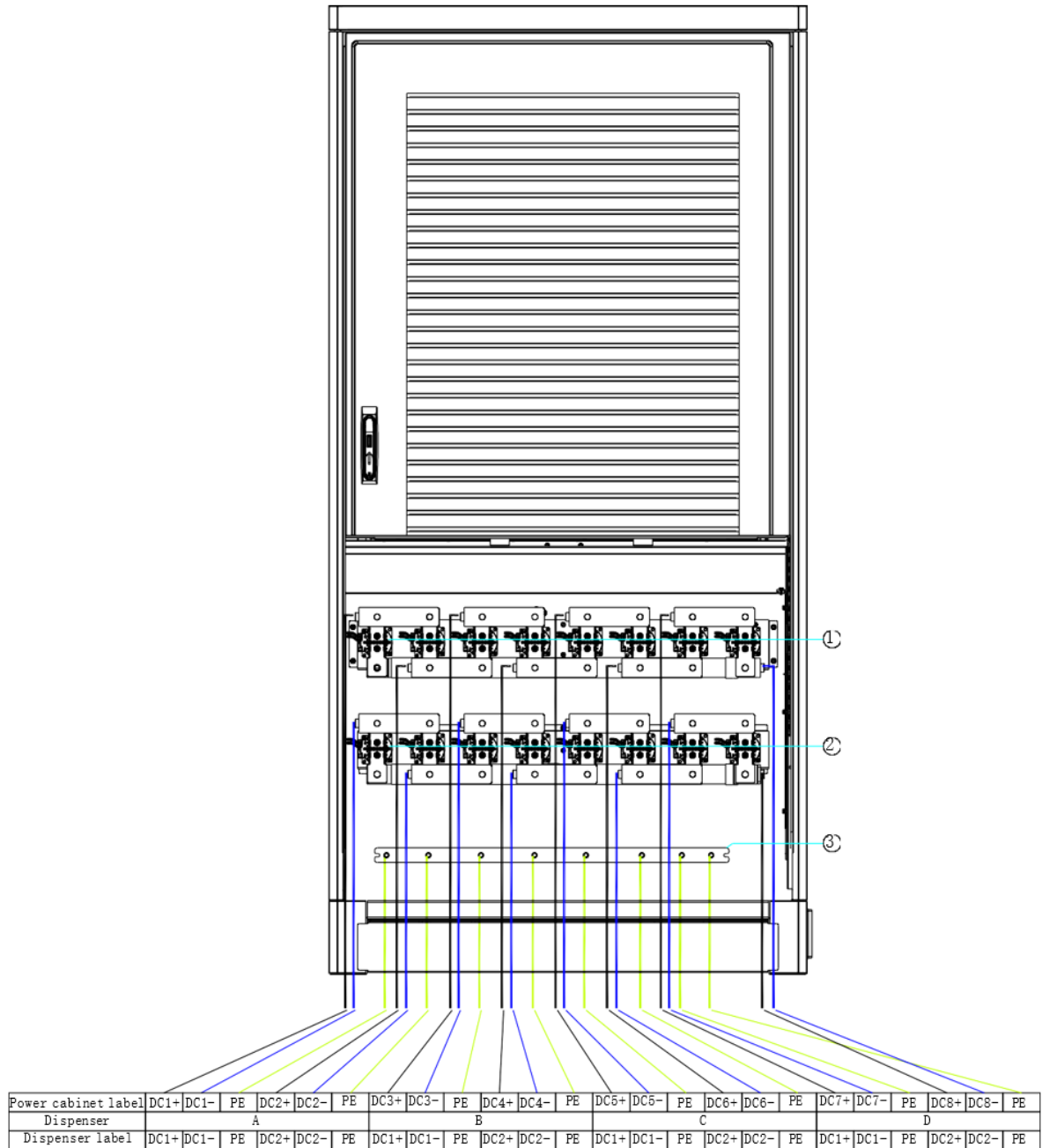

①	KMD	DC contactor
②	KMD	DC contactor
③	PE	Grounding copper bar

Figure 5.14 Power Cabinet DC Output

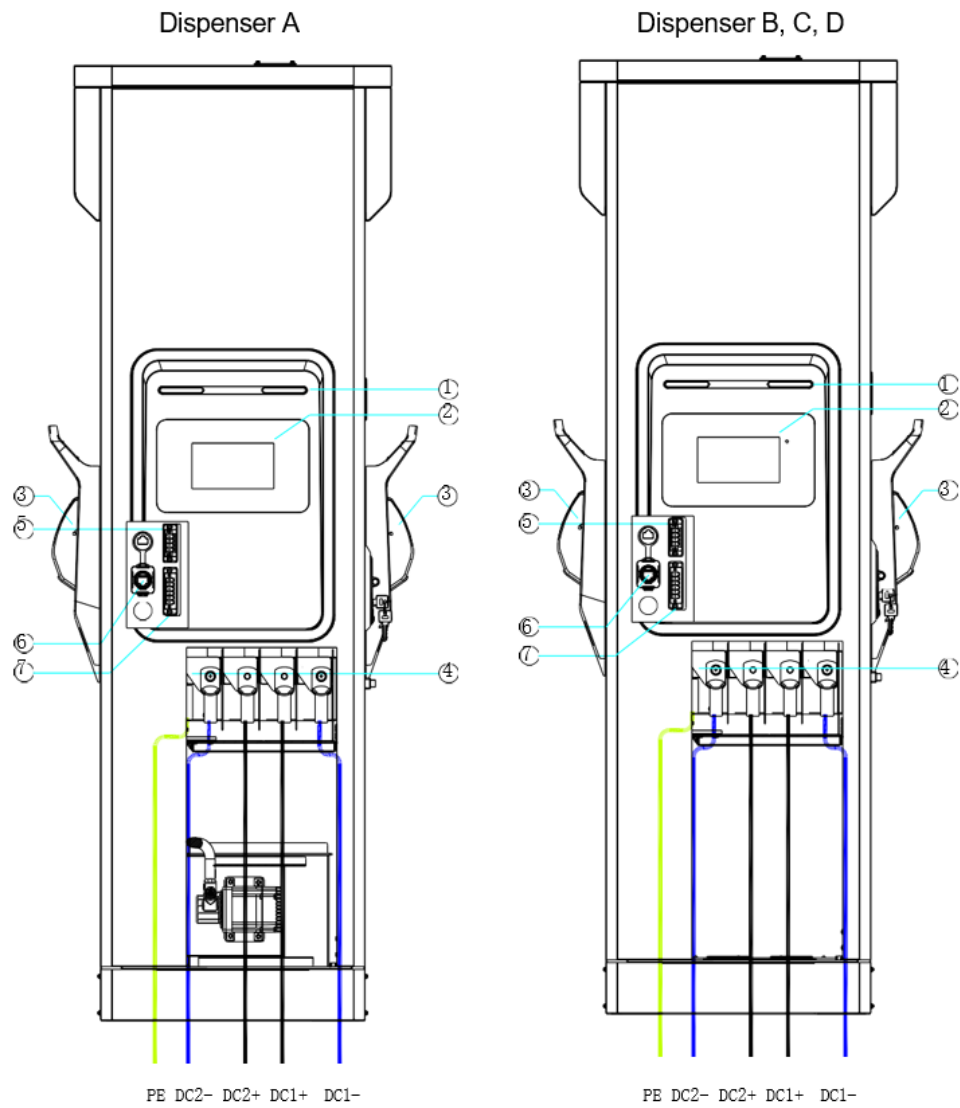

①	LED	Light emitting diode
②	LCD	Touch screen
③	CCS1/CCS2	Charging Connector
④	DC	DC input copper bar
⑤	J1	Auxiliary power supply
⑥	ETH	Network interface
⑦	J2	Communication signal connector

Figure 5.15 Dispenser DC Output

Micro Dispenser E,F,G

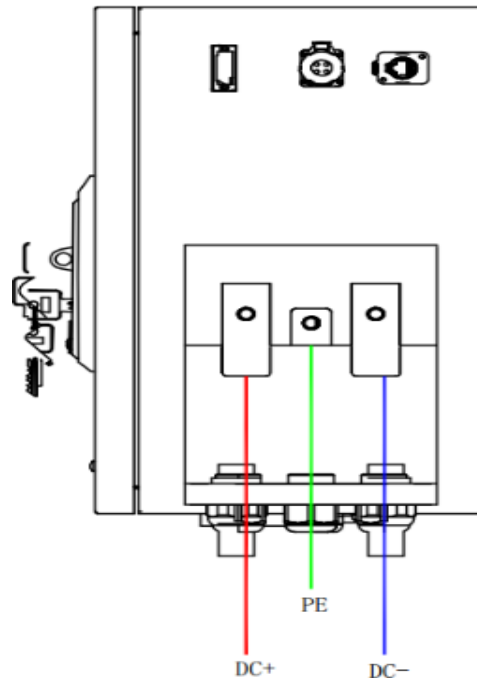

Figure 5.16 Dispenser DC Input

5.4.5.3) Connection of Signal Cables (Slim Line Dispenser)

- The Signal and Auxiliary power connection between Power Cabinet and the Slim Line Dispenser are shown in Figure 5.17 and Cable selection according to table 5-2.

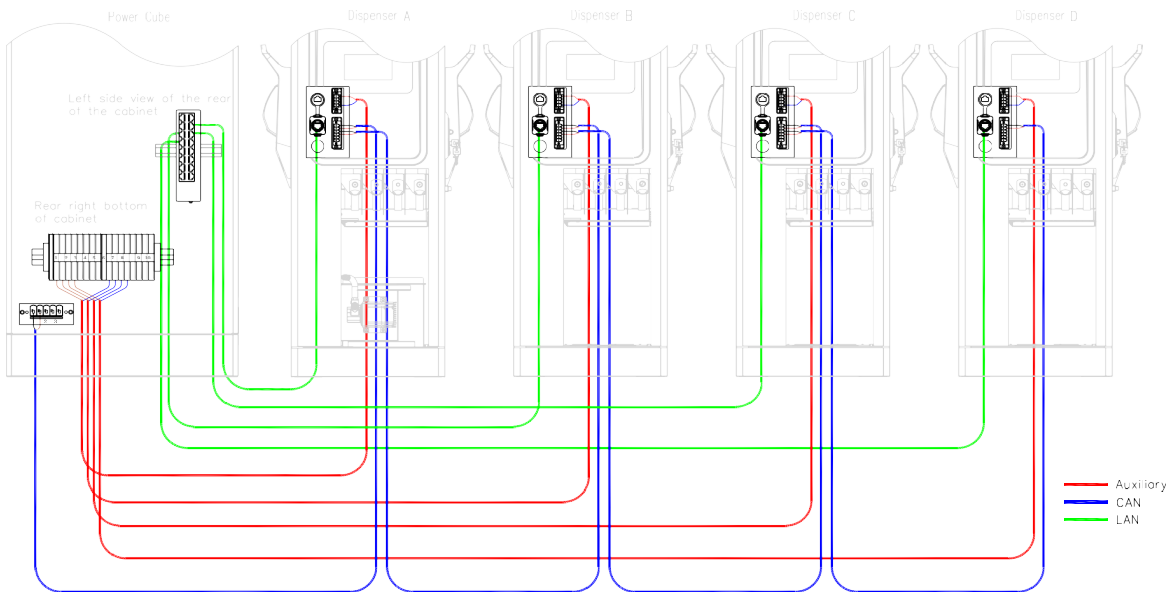

Figure 5.17 Power Cabinet auxiliary power supply and signal cable connection diagram for Slim Line Dispenser.

5.4.5.4) Connection of Signal Cables (Micro Dispenser)

- The Signal and Auxiliary power connection between Power Cabinet and the Micro Dispenser are shown in Figure 5.18 and Cable selection according to table 5-2.

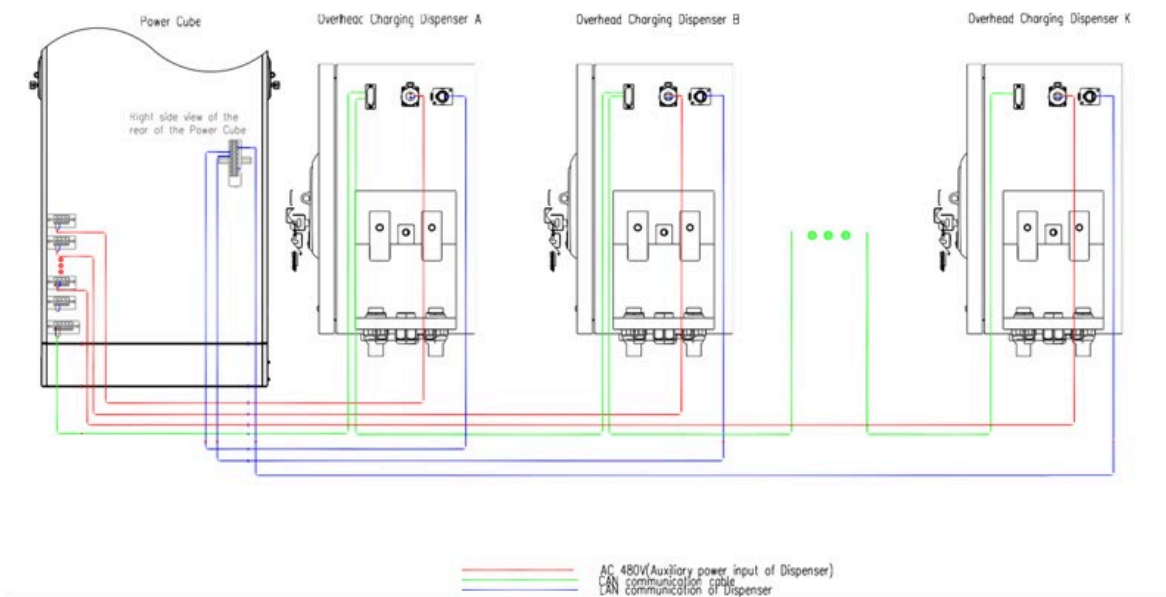

Figure 5.18 Power Cube auxiliary power supply and signal cable connection diagram

5.4.5.5) Connection of Network Cable (Slim Line Dispenser)

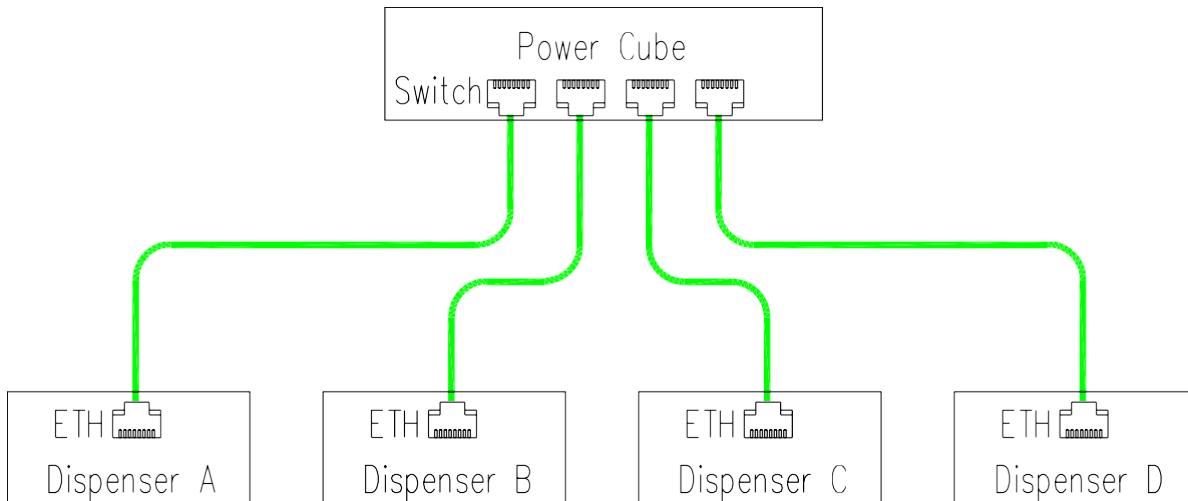

Figure 5.19 Network cable connection diagram for Slim Line Dispensers

5.4.3.6) Connection of Signal Cable (Slim Line Dispenser)

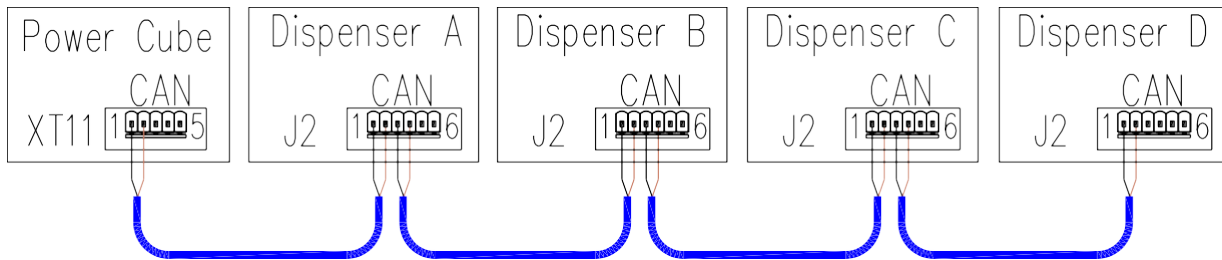

Figure 5.20 Signal cable connection diagram for Slim Line Dispensers

5.4.5.7) Auxiliary Power Cable Connection (Slim Line Dispenser)

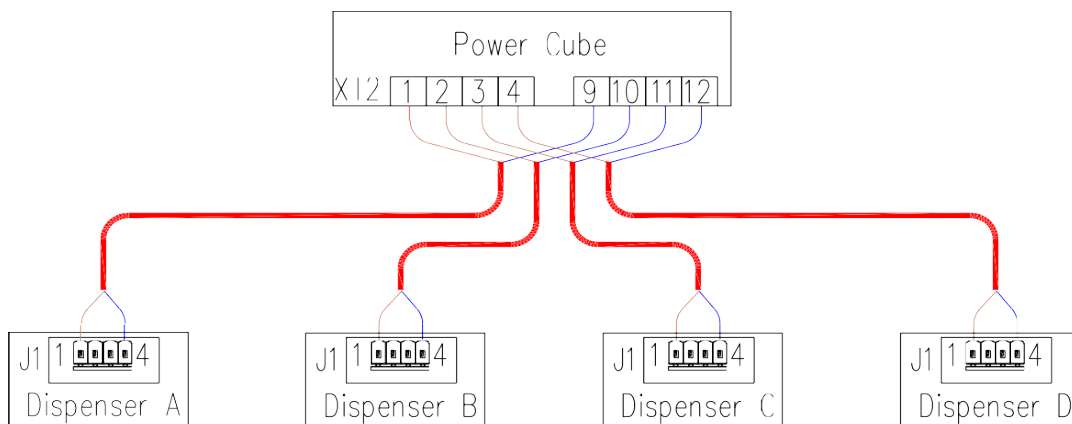

Figure 5.21 Power Cabinet and Dispenser Auxiliary power connection diagram for Slim Line Dispensers

5.4.5.8) Connection of Signal Cable (Micro Dispenser)

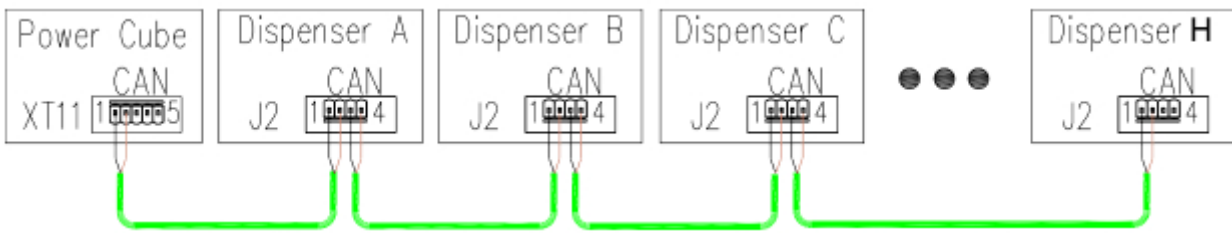

Figure 5.22 Signal cable connection diagram for Micro Dispenser

5.4.5.9) Connection of Signal Cable (Micro Dispenser)

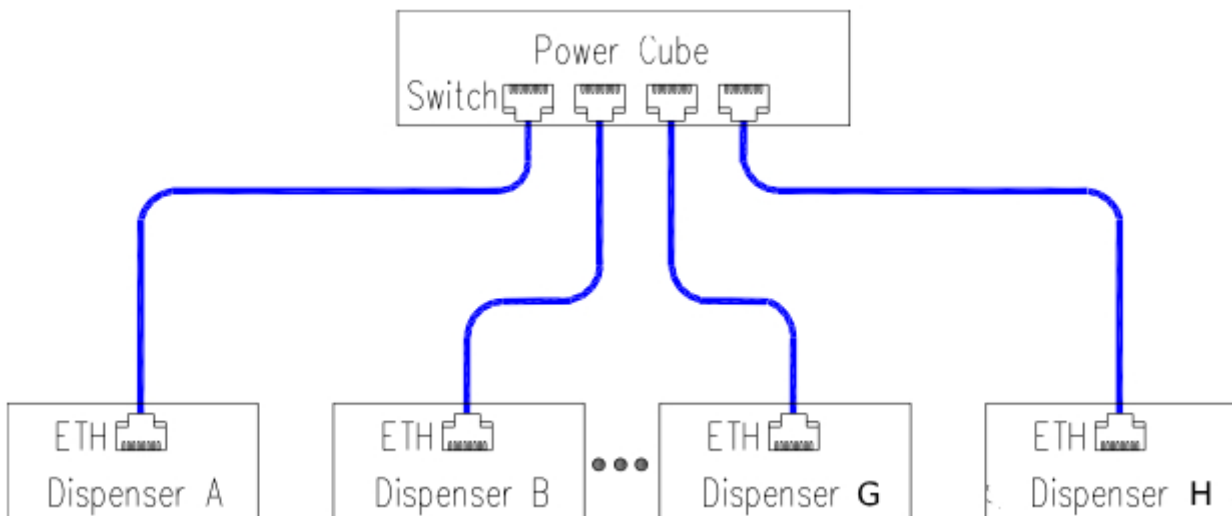

Figure 5.23 Network cable connection diagram for Micro Dispenser

5.4.5.10) Auxiliary Power Cable Connection (Micro Dispenser)

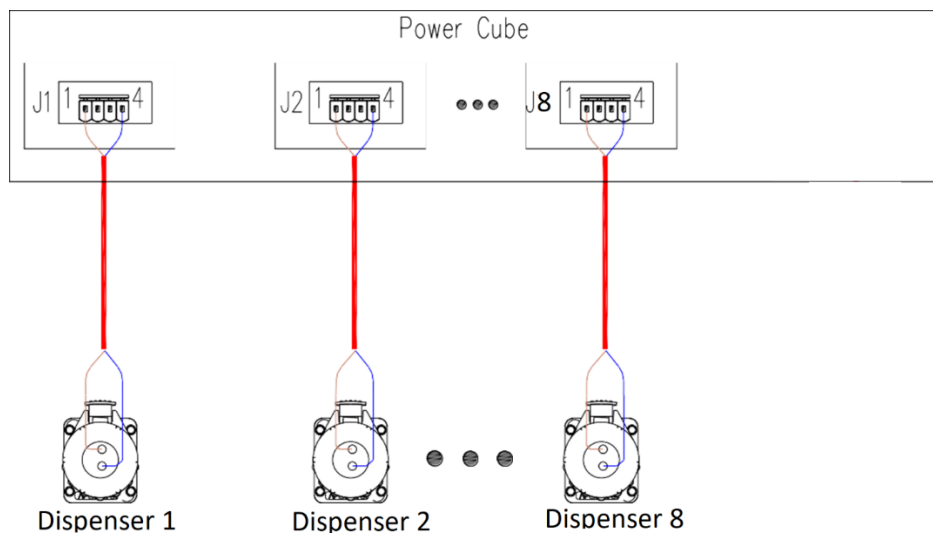
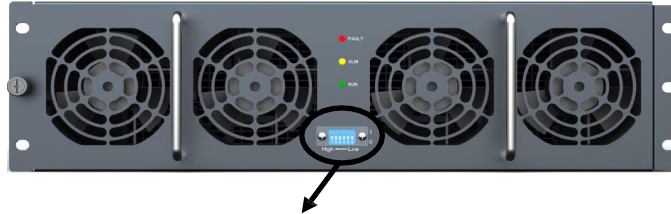

Figure 5.24 Power Cabinet and Dispenser Auxiliary power connection diagram for Micro Dispensers

5.4.6) Power Module Installation

- For the ICE-360/480 split type eight-gun four dispenser system, the charging module needs to be divided into eight groups. Each Group of charging modules must be addressed properly for the system to recognize which group slot the module is installed into.
- Set the appropriate dial switch for each charging module as shown in the following figure 5.25 and 5.26 below:



Dial Switch, Left High, Right Low

Figure 5.25 Front view of Power Module

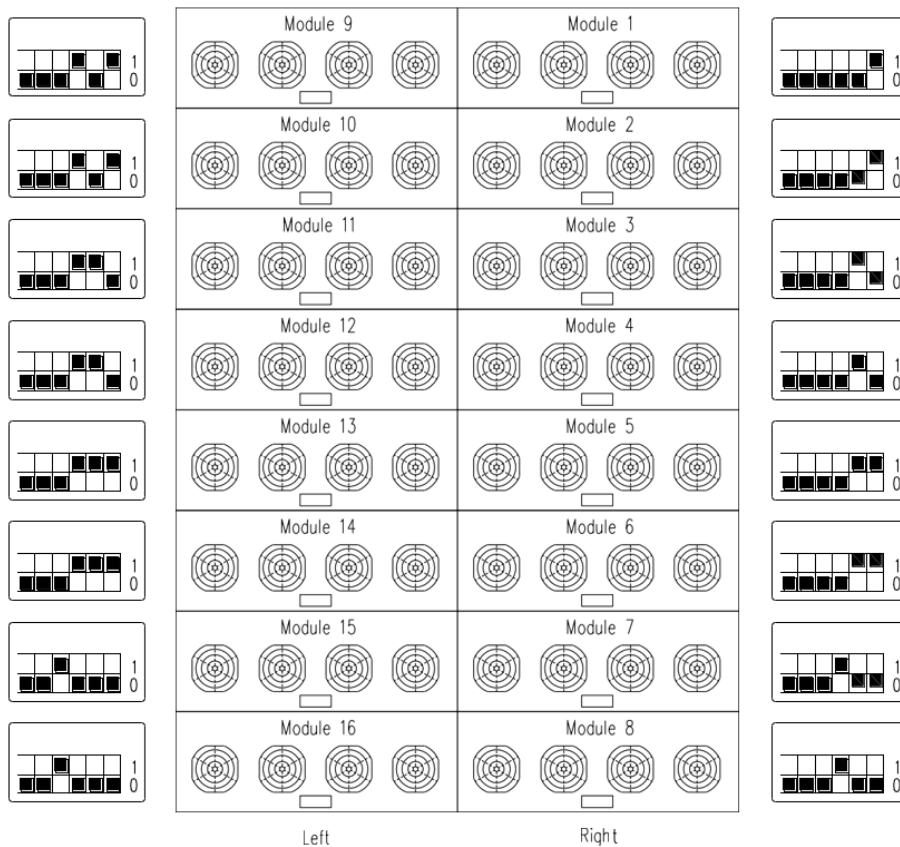



Figure 5.26 Power Cabinet front view of Power Modules

 Caution	<p>The charging module is heavy. Please be careful when moving the module.</p> <p>If the system is configured to less than 480kW output power, some power modules may be removed. The empty charging module slots must be covered by blanking plates. Otherwise, the system thermal management will not function correctly.</p>
---	---

5.5) Controller Setting

Notes: Power Cabinet and Charging Dispenser Controller address settings. See Appendix 2 for the electrical connection of the 480kW split system.

5.5.1) Address Settings

- The ADD of the controller marked as "IMSU-X" in the Power Cabinet does not require an address to be set.
- The ADD of the controller labeled " IMSU-X " in Dispenser A should be set to 0, pin1 set to OFF, pin2 set to OFF, pin3 set to OFF, and pin4 set to OFF.

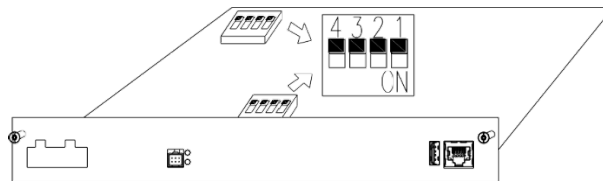

- The ADD of the controller labeled " IMSU-X " in Dispenser B should be set to 1, pin1 set to OFF, pin2 set to OFF, pin3 set to OFF, and pin4 set to ON.

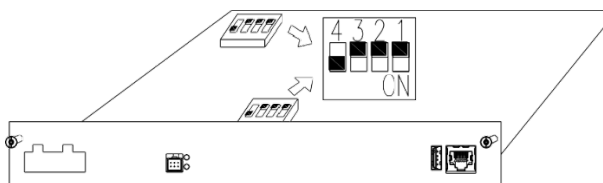

- The ADD of the controller labeled " IMSU-X " in Dispenser C should be set to 2, pin1 set to OFF, pin2 set to OFF, pin3 set to ON, and pin4 set to OFF.

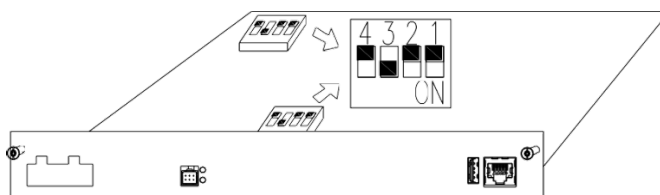

- The ADD of the controller labeled " IMSU-X " in Dispenser D should be set to 3, pin1 set to OFF, pin2 set to OFF, pin3 set to ON, and pin4 set to ON.

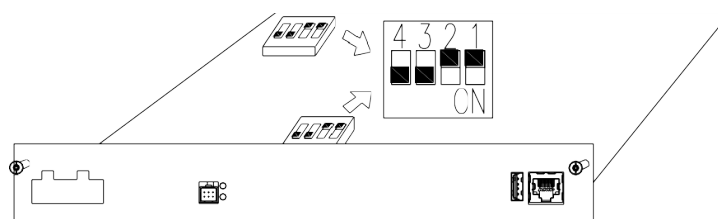

- If using Micro Dispensers and there are more than a total of 4 dispensers in the system, identify the dispensers in series with A thru H and address as follows:
 - The ADD of the controller labeled " IMSU-X " in Dispenser E should be set to 4, pin1 set to OFF, pin2 set to ON, pin3 set to OFF, and pin4 set to OFF.
 - The ADD of the controller labeled " IMSU-X " in Dispenser F should be set to 5, pin1 set to OFF, pin2 set to ON, pin3 set to OFF and pin4 set to ON.
 - The ADD of the controller labeled " IMSU-X " in Dispenser G should be set to 6, pin1 set to OFF, pin2 set to ON, pin3 set to ON and pin4 set to OFF.
 - The ADD of the controller labeled " IMSU-X " in Dispenser H should be set to 7, pin1 set to OFF, pin2 set to ON, pin3 set to ON and pin4 set to ON.

5.5.2) Resistance Setting

- The CAN communication line between the Dispensers is connected in a hand in hand manner. A 120 Ω resistor needs to be retained on the monitoring IMSU-X-CAN3 of the last Dispenser D, while the remaining CAN3 resistors of Dispenser A, Dispenser B, and Dispenser C are removed to ensure that the CAN bus is 60 Ω .
- Remove the CAN3 resistors from three Dispenser A, B, C. As shown in Figure 5.27. Move the resistor to pin 2 and 3.

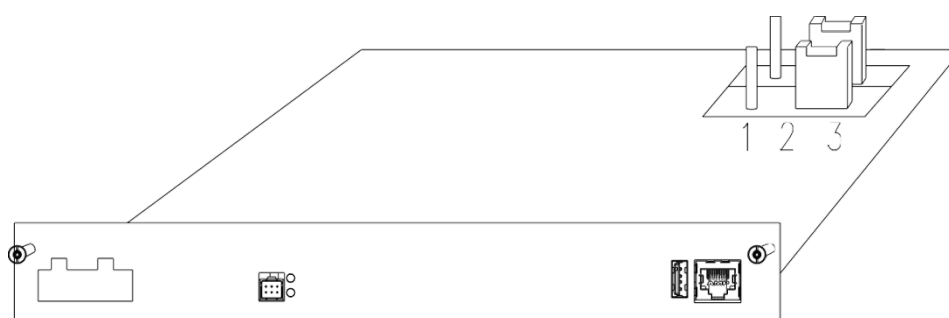

Figure 5.27 Resistance Setting Diagram

- Dispenser D follows factory settings and does not require adjustment. As shown in Figure 5.28:

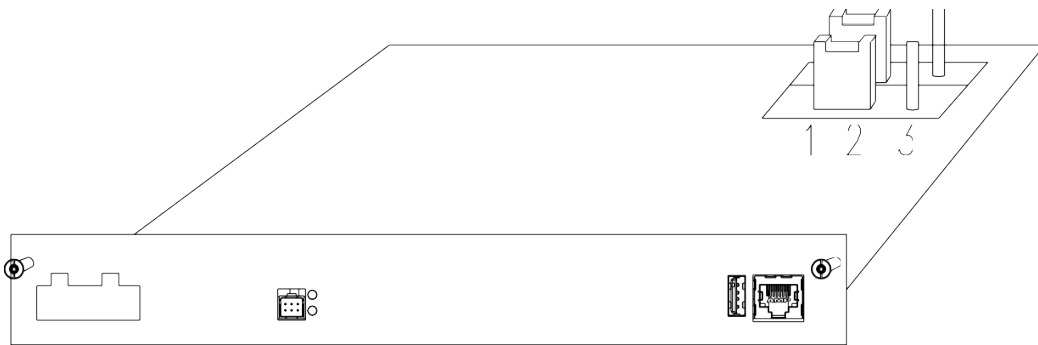

Figure 5.28 Resistance Setting Diagram

- Controller Dialing and resistance settings are shown in figure 5.29

NOTE: The last dispenser in the system will have the CAN resistor jumpers set on pins 1 and 2, and all other dispensers will have the CAN resistor jumpers set on pins 2 and 3.

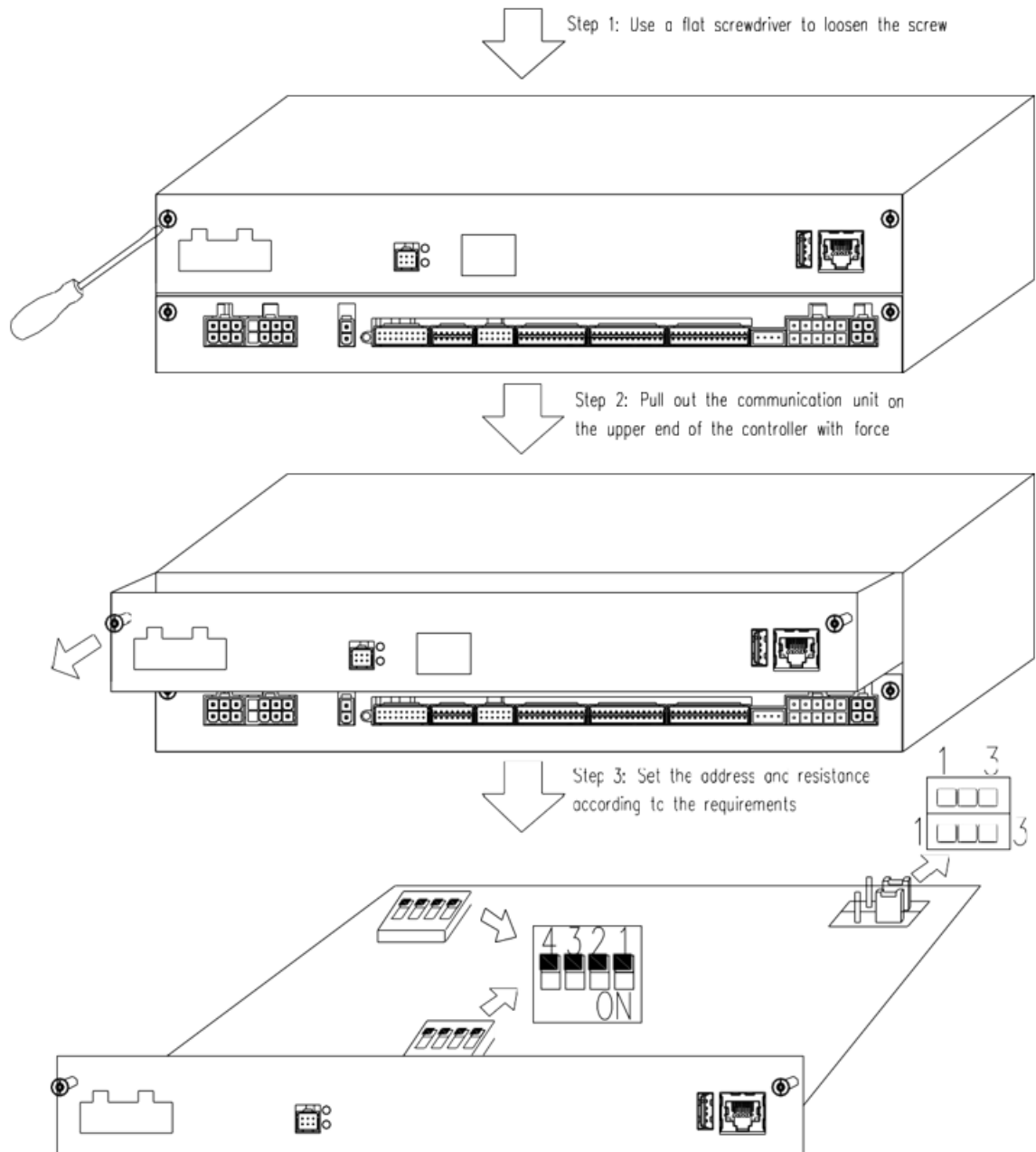

Figure 5.29 Address setting diagram

6.) Adding Cooling Liquid

6.1) Charging Dispenser Cold Source Description

- Liquid cooling system by the pump, reservoir, hoses, radiator, fan, pressure sensors, temperature sensors, liquid level alarm switch, drive controller, etc., As shown in Figure 6.1 below

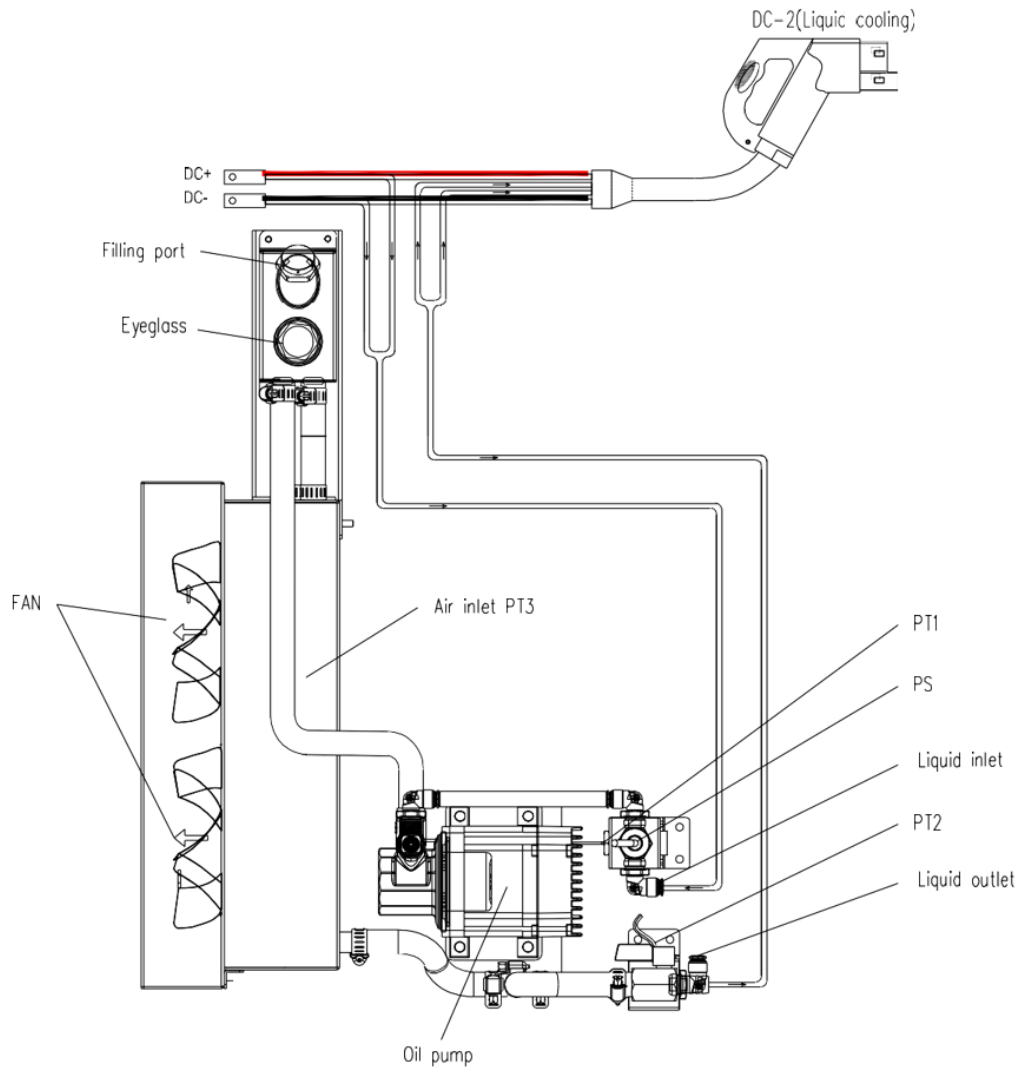

Figure 6.1 Schematic diagram of cold source of the Slim Line Dispenser

6.2) Liquid Cooled Cable System

- The cable system consists of connector no.1, cable no.2, cable fixture no.3, terminal to power supply no.4, ground wire no.5, pipes for coolant no.6, sensor and communication wires no.7. The cable system is fully assembled and only must be connected to the charging station. As shown in Figure 6.2 below:

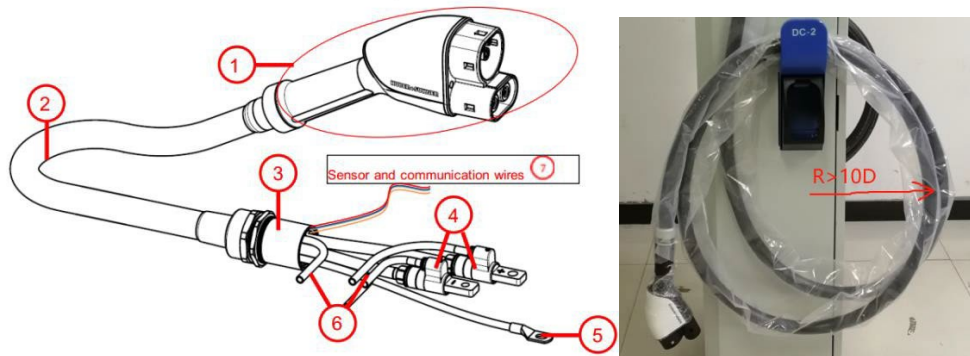

Figure 6.2 Schematic diagram of CCS1 liquid cooling connector

Notes

- There is a coolant pipe inside the liquid cooling connector. Users should ensure the minimum bending radius during charging $R > 10D$.
- CCS liquid cooling connector: $10D = 10 * 1.2 = 12\text{in}$ ($10 * 31.5 = 315\text{mm}$)
- GBT liquid cooling connector: $10D = 10 * 1.6 = 16\text{in}$ ($10 * 40 = 400\text{mm}$)

6.3) Adding Liquid Step

- Prepare a funnel and a 5L (1.32 Gal) measuring cup, 6L (1.60 Gal) of silicone oil specified by the manufacturer.
- Note: Huber silicone oil shall be used for CCS connector and 8025 Coolant oil shall be used for GBT liquid cooling connector. The two must not be mixed!



- Remove the fixing screws of the protective filter on the front of the charging terminal 6pcs*M4.

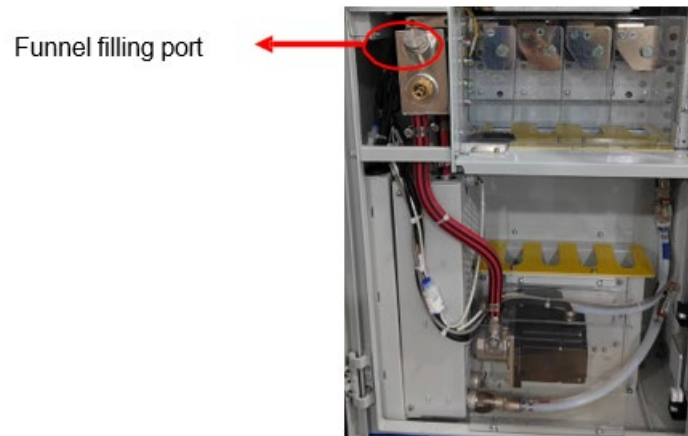

Figure 6.3 Front view of Dispenser

- Open the cooling source filling port bolt.
- Introduce 2200mL (0.60 Gal) of silicone oil into the measuring cup, add it to the fuel tank twice, add 1600mL to the fuel tank for the first time (always observe the oil level and stop adding liquid when the oil is below the high liquid level visual window), and tighten the filling port bolt.
- Once the system is powered on (see section 7), conduct the manual running of the liquid cooling system in each dispenser (as applicable). Perform the liquid cooling system oil circuit test. Observe that there is no leakage in the oil circuit and the oil pressure of the charging interface is normal (about 0.6~0.7Mpa). Ensure the oil temperature of connector is normal and it runs stably for 30 minutes. After the oil level is lower than the high liquid level sight window, open the cold source liquid filling port and add approximately 600mL (0.16 Gal) of silicone oil to the oil tank until you can see the level in the sight window. Ensure the oil level does not go above the high liquid level sight window. Tighten the liquid filling port cap. Turn off oil pump.
- **Note 1:** See Section 7 (START-UP) for powering on system. See Section 8 for Charging Dispenser startup and touch screen parameter settings.
 - **Notes:** The oil pressure is too low or 0 during the operation of the oil pump, please see if the oil pipe connection is in place.
- Finally, install the protective filter on the front of the Charging Dispenser, and the cold source system is filled with liquid.

7.) Start Up

7.1) Verification and Inspection

- Check if the bolts of the AC and protective ground cables of the ICE-360/480 are correctly tightened to the specified torque
- Check the resistance between the ICE-360/480 protective ground and the low voltage switchboard ground connection; the value must be according to local codes.
- Grid AC with L1/L2/L3/PE wiring or DC+/DC-/PE wiring for DC input.
- Power modules panel address setting is correct.
- Before switching ON all the fuses and circuit breakers, check the supply voltage between lines: it must be $480V \pm 10\%$ 50/60Hz.

7.2) Switch On

- Grid AC input connection wiring (L1, L2, L3, PE) to Main breaker
- Check all switches in the system are off (System Main breaker, AC output breaker, Aux power input breaker).
- Plug in the power modules as needed. If there is an empty slot, a blank cover must be installed in the empty slot(s) for proper air flow inside the Power Cabinet.
- Turn AC Grid power on, then check input voltages at the Power Cabinet. Verify voltages are 480VAC Phase to Phase and 277VAC Phase to PE. If voltages are not within tolerance, stop and verify system is fed with a 480/277VAC WYE electrical feed, check all input connections and wiring and try again.
- First switch on the auxiliary power switch 3QF and 4QF of the Power Cabinet, as shown in Figure 7.1

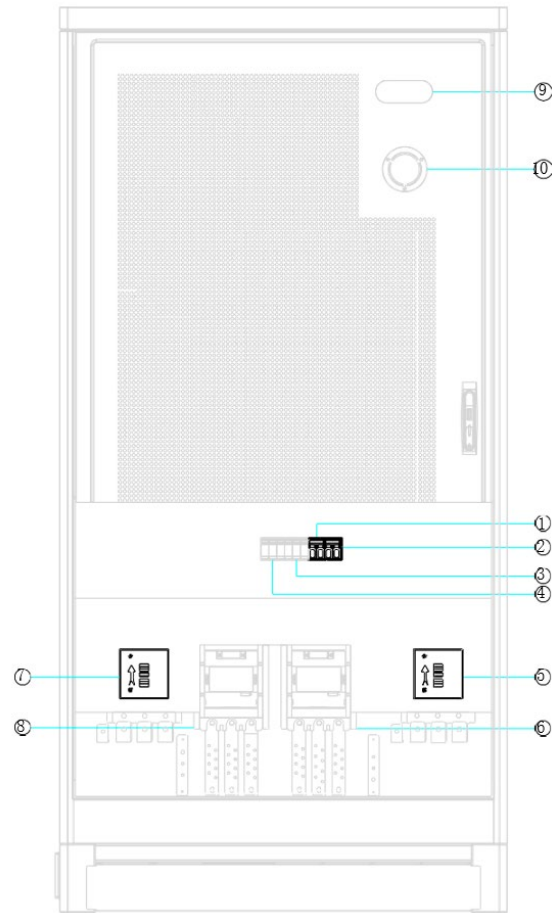

①	4QFP	Auxiliary Power for Power Cabinet
②	3QFP	Auxiliary Power for Dispenser
③	1SPD	AC SPD
④	2SPD	AC SPD
⑤	1QF	AC Input MCCB
⑥	1KMA	Main contactor
⑦	2QF	AC Input MCCB
⑧	2KMA	Main contactor
⑨	LED	Light emitting diode
⑩	ESD	Emergency Shutdown Device

Figure 7.1 Front view of Power Cabinet

- Next, switch on the auxiliary power switches QFP of charging Dispenser A, B, C, and D respectively, as shown in Figure 7.2

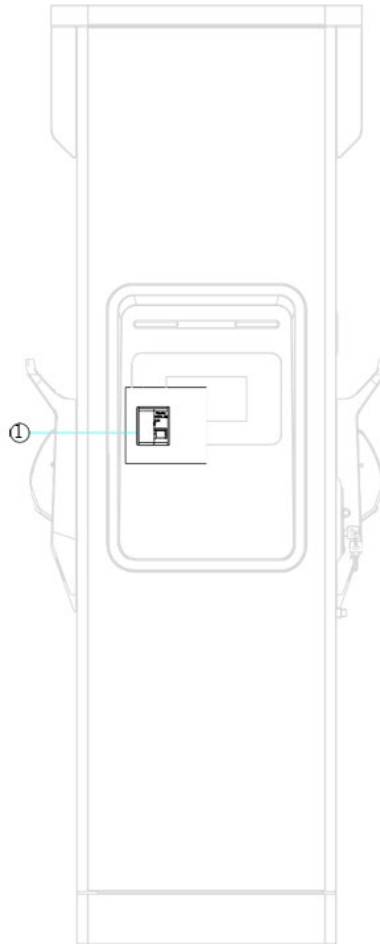

①	QFP	AC Input for Auxiliary Power
---	-----	------------------------------

- Check all controllers and meters, LCD and LED.
- Switch the main circuit breakers 1QF and 2QF of the Power Cabinet system to enable the power module input., as shown in Figure 7.1.
- Finally check the alarm from the front panel LED and Display for information about the system. If all parameters are set properly and all self-checks are clear, no alarms should be present. If alarms are present, address as needed to clear all alarms.

Notes:

- Please add liquid to the cold source system of the charging terminal before starting the system, otherwise the cold source system will fail to start properly due to improper oil level. The cold source system needs to be tested at the first power-on, and silicone oil is added to a reasonable position. (See Chapter 6 ADD LIQUID)

8.) Important Parameter Settings

Note: Before configuring any of the system components. Go to section 11.4.1 for the router set up procedure.

8.1) Dispenser Parameter Setup

- The parameter settings of the dispensers are basically the same as those of the integrated charger. The dispenser only has some unique parameter settings for the split charging system; Therefore, here we only introduce some parameters related to split charging system dispenser. Please refer to Document <IMMU2 Upper Controller Maintenance Guideline> for the remaining parameter settings.
- Notice: The parameters introduced below are essential to set after the system is installed.
- Login to the screen of the dispenser using the Root Login.
- 1. “Param Set” ->“Charger System” ->“Charger Type”

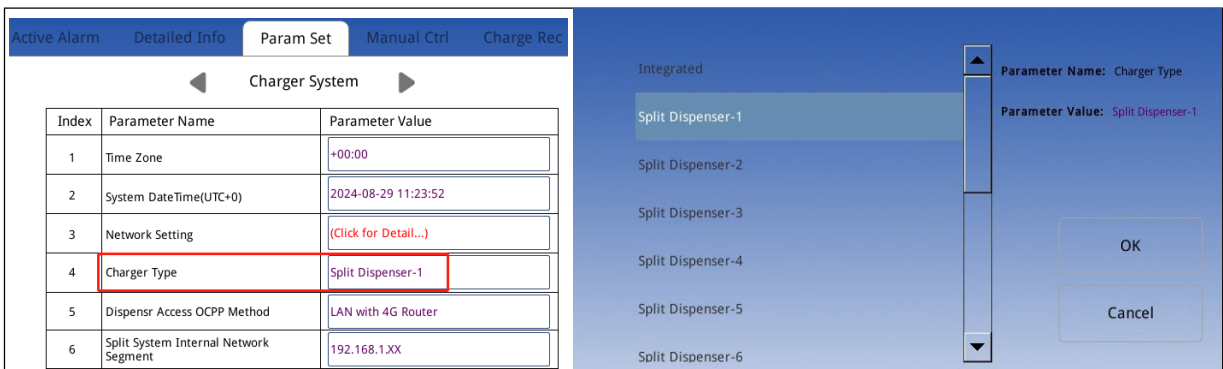

Index	Parameter Name	Parameter Value
1	Time Zone	+00:00
2	System DateTime(UTC+0)	2024-08-29 11:23:52
3	Network Setting	(Click for Detail...)
4	Charger Type	Split Dispenser-1
5	Dispenser Access OCPP Method	LAN with 4G Router
6	Split System Internal Network Segment	192.168.1.XX

- The default value of parameter Charger Type is Integrated, and the split system dispenser needs to be set to the corresponding value, such as Dispenser-1 being set to 'Split Dispenser-1', Dispenser-2 being set to ' Split Dispenser-2', Dispenser-3 being set to ' Split Dispenser-3', and so on. This parameter is associated with the IP address of Upper ETH1, which will fix the IP address of ETH1 to 192.168.1.201~192.168.1.210. After setting this parameter, it needs to be restarted to take effect.

- 2. “Param Set” ->“Charger System” ->“Dispenser Access OCPP Method”

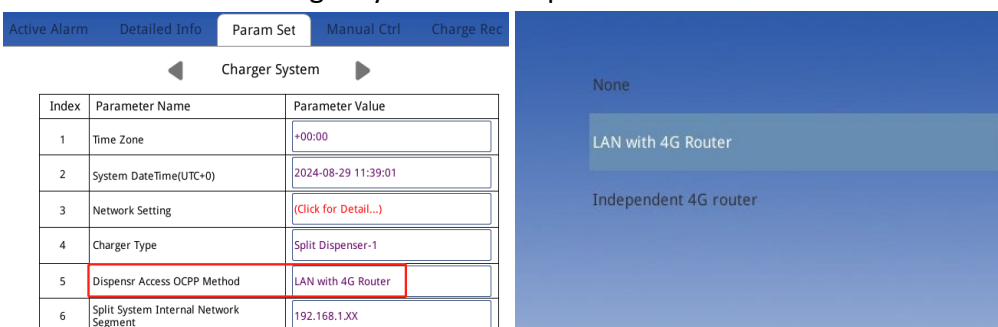

Index	Parameter Name	Parameter Value
1	Time Zone	+00:00
2	System DateTime(UTC+0)	2024-08-29 11:39:01
3	Network Setting	(Click for Detail...)
4	Charger Type	Split Dispenser-1
5	Dispenser Access OCPP Method	LAN with 4G Router
6	Split System Internal Network Segment	192.168.1.XX

This parameter is a setting item for the dispenser access OCPP server method. It can choose from the above three values; the default value is LAN with 4G Router. The meaning of the three values are:

- **None:** The dispenser does not access OCPP Server, and the split charging system is connected to OCPP server through PC-Upper Controller.
- **LAN with 4G Router:** The dispenser accesses the OCPP server through a 4G router connected to the system LAN switch located in the PC. Please ensure that the IP address of the 4G router connected to the power cabinet switch is 192.168.1.1.
- **Independent 4G Router:** Each dispenser uses an independent 4G router to access the OCPP server. In this condition, the independent 4G Router will occupy the ETH1 of the Upper, so the network cable from the dispenser to the power cabinet does not need to be connected.
 - NOTE: To connect a Dispenser to an OCPP Server, 'OCPP Server End URL' and 'Charger ID' settings also should be set.

3. "Param Set" ->"Charger System" ->"Split System Internal Network Segment"



Index	Parameter Name	Parameter Value
1	Time Zone	+00:00
2	System DateTime(UTC+0)	2024-09-05 01:42:27
3	Network Setting	(Click for Detail...)
4	Charger Type	Split Dispenser-1
5	Dispensr Access OCPP Method	LAN with 4G Router
6	Split System Internal Network Segment	192.168.1.XX

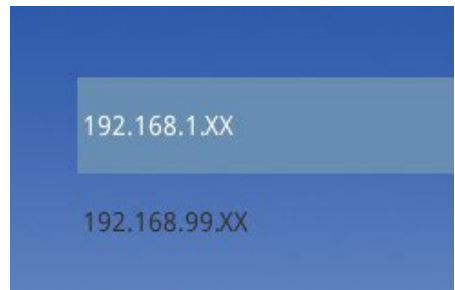

- This parameter is the network segment used by the dispenser to access the system LAN. The default value is "192.168.1. XX", and the other value is used by other systems.
- 4. "Param Set" ->"Charger System" ->"CCU Work Mode"

Index	Parameter Name	Parameter Value
1	Charger/CCU Specific Settings	(Click for Detail...)
2	Smart Charge Accuracy Compensation	0%
3	AC Main input includes AC connector input	Yes
4	CCU Work Mode	Standalone TCP
5	Is the Liquid Module Installed	No
6	Liquid-cooled Connector Installing type	Not Installed

- This parameter is the communication method between the dispenser upper controller and the pilot controller. The default value is Standalone TCP, be careful not to modify the default value.

5. "Param Set" -> "Charger System" -> "PC DC Output Number of Connector-A/B"

Index	Parameter Name	Parameter Value
7	PowerCabinet System Fan Startup Speed	50%
8	PowerCabinet System Fan Full Speed	50%
9	Trickle Charge Start SOC	101%
10	PC DC Output Number of Connector-A	1
11	PC DC Output Number of Connector-B	2
12	PLC&CHAdemo log grab type	RS232(for Gridwiz&RNL)

- These parameters are the DC output numbers of the power cabinet corresponding to the dispenser connectors A/B.

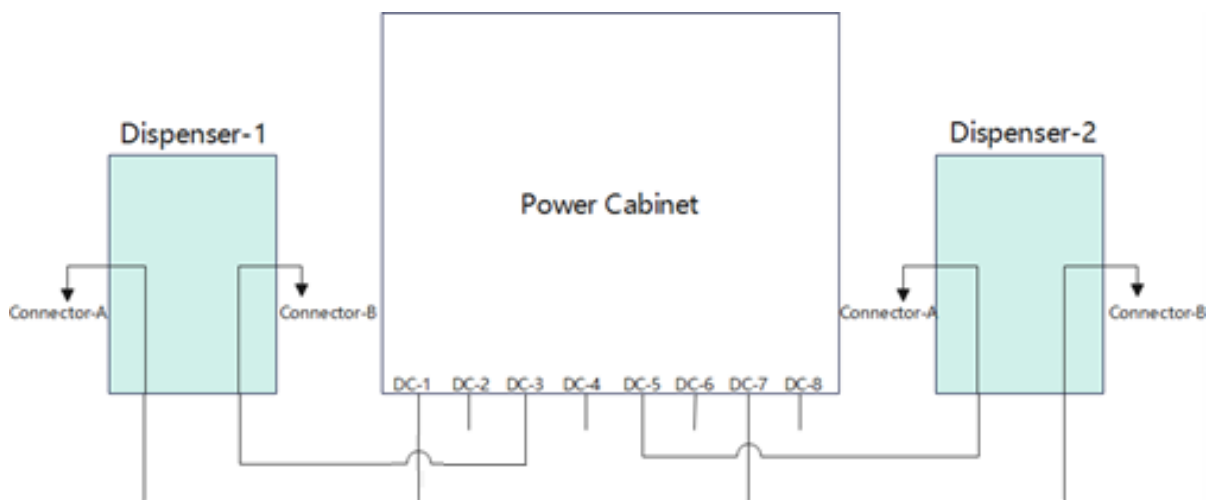

- In the above example where only 2 slim line dispensers are installed, Dispenser-1 connector A is connected to power cabinet DC-1 and connector B is connected to power cabinet DC-3. Dispenser-2 connector A is connected to power cabinet DC-5 and connector B is connected to power cabinet DC-7. So, dispenser-1 should be set as 1 and 3, dispenser-2 should be set as 5 and 7.
 - If the dispenser installed is a Micro-Dispenser, only the parameter of connector-A should be set to the proper PC output, and connector-B should be set to 0.
- See Section 9 for a full list of configuration settings and appropriate values/ranges.

8.2 Power Cabinet Parameter Setup

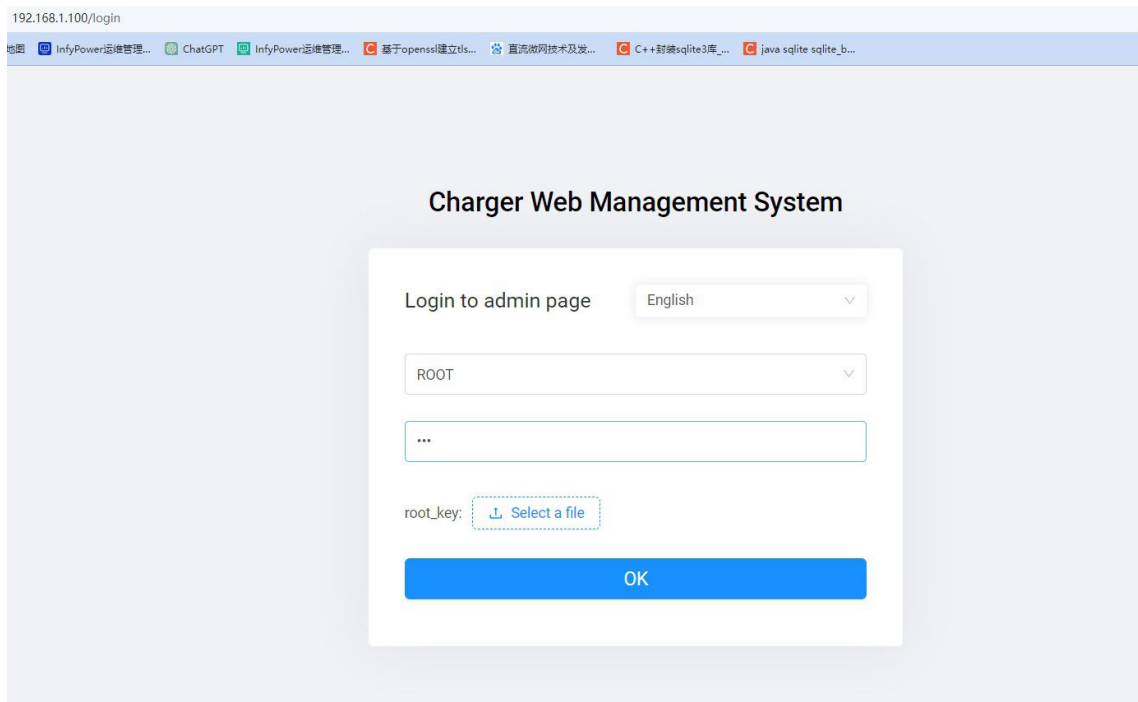

- The Power Cabinet Upper Controller does not have an HMI, so a webpage is used to access the power cabinet upper controller for parameter settings and information display.
- To access this, use an Ethernet cable and connect a laptop to The ETH2 port on the Upper Controller. Open a web browser and go to IP address 192.168.99.100. Login using the ROOT access password and root key file.

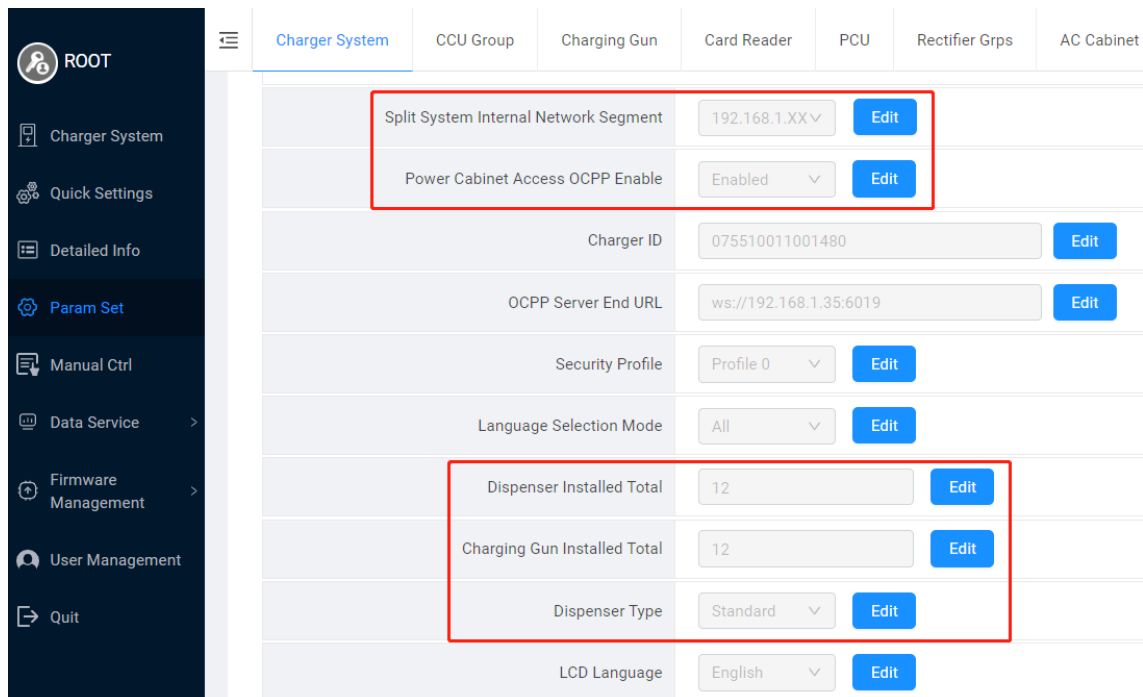

Parameter	Value	Action
Split System Internal Network Segment	192.168.1.XX	Edit
Power Cabinet Access OCPP Enable	Enabled	Edit
Charger ID	075510011001480	Edit
OCPP Server End URL	ws://192.168.1.35:6019	Edit
Security Profile	Profile 0	Edit
Language Selection Mode	All	Edit
Dispenser Installed Total	12	Edit
Charging Gun Installed Total	12	Edit
Dispenser Type	Standard	Edit
LCD Language	English	Edit

- 1. “Param Set” ->“Charger System” ->“Split System Internal Network Segment”
 - This parameter is the network segment used by the power cabinet upper controller to access the system LAN. The default value is "192.168.1. XX", and the other value is used by other systems.
- 2. “Param Set” ->“Charger System” ->“Power Cabinet Access OCPP Enable”
 - If the power cabinet needs to access the OCPP server, this parameter needs to be set to Enable, ‘OCPP Server End URL’ and ‘Charger ID’ also should set. See Section 7.3 for details.
- 3. “Param Set” ->“Charger System” ->“Dispenser Installed Total”
 - Set the total number of dispensers installed in the system.
- 4. “Param Set” ->“Charger System” ->“Charging Gun Installed Total”
 - Set the total number of charging guns that are installed in the system.
- 5. “Param Set” ->“Charger System” ->“Dispenser Type”
- 6. “Param Set” ->“PCU” ->“PCU Settings”
 - The PCU setting parameters are related to the power cabinet, and these parameters are very important. Some of these parameters must be set before the system runs.

PCU

PCU Settings [Edit](#)

Firmware Version	1.07	IMSU-X Hardware Version	A02
Boot Version	02.00	IMSU-X Startup Times	37
Door Open Alarm Enable	Disabled	SPD Alarm	Enabled
EPO Voltage Level	Alarm Normally Open	Total PM Grp Number	12
Total PM Number	20	Total DC output	5
Total Dispenser Number	4	Soft-start Time	1 seconds
AC Meter Ratio	150	AC Sleep Interval	0 min
Input Over Voltage Point	450 v	Input Under Voltage Point	310 v
Output Max Voltage	1050 v	Contactora Abnormal Judge Time	2 seconds
PM inlet overheating point	80 °C	PM outlet overheating point	93 °C
Busbar Lv1 overheating point	90 °C	Busbar Lv2 overheating point	120 °C
Temperature alarm hysteresis	5 °C	Busbar overheating curr lmt period	5 min
Busbar overheating curr lmt percent	80 %	Cooling Devices Type	Air cooling
AC Input Power Limit	10000 kW	Cabinet Fun Min Speed	25 %
Cabinet Fun Max Speed	100 %	Power Cabinet Fan Min Speed Temperature	40 °C
Power Cabinet Fan Full Speed Temperature	70 °C	Busbar Temperature Sensor Install	Not installed
PDU Inner Ring Enable	Yes	AC Input Single	No
Air cooled PC Outlet Over Temperature Lv1	90 °C	System Efficiency Setting	93 %
		Air cooled PC Outlet Over Temperature Lv2	100 °C

Parameter Name	Description	Value Range	Default Value	Remark
PCU Firmware Version	/	Read Only	/	
IMSU-X Hardware Version	/	Read Only	/	
Boot Version	Boot Loader Version	Read Only	/	
IMSU-X Startup Times	PCU Startup Times	Read Only	/	
Door Open Alarm Enable	/	Enable / Disable	Enable	
SPD Alarm Enable	/	Enable / Disable	Enable	
EPO Voltage Level	/	Alarm Normally Close / Alarm Normally Open	Alarm Normally Close	
Total PM Grp Number	The total number of power module groups in the power cabinet	0 ~ 16	8	must be manual set
Total PM Number	The total number of power modules in the power cabinet	0 ~ 32	16	must be manual set
Total DC Output Number	The total number of DC output busbar in the power cabinet	0 ~ 16	16	must be manual set
Total Dispenser Number	The total number of dispensers in the system	0 ~ 12	6	must be manual set
Soft-start Time	Soft start time of power module	0~255 S	1 S	
AC Meter Ratio	If the system has a AC meter, this parameter needs to be set	1~99999	160	
AC Sleep Interval	The time interval for the system to enter sleep mode from idle. If set to 0, it means the system will not enter sleep mode	0 ~ 255 S	0 S	
Input Over Voltage Point	If the input line voltage is greater than this value, an alarm will be triggered	0 ~ 2000 V	450 V	
Input Under Voltage Point	If the input line voltage is less than this value, an alarm will be triggered	0 ~ 2000 V	310 V	

Output Max Voltage	The maximum voltage that the power module can output	0 ~ 2000 V	1050 V	
Contactor Abnormal Judge Time	After controlling the contactor, determine the time interval for abnormal contactor status	0 ~ 255 S	2 S	
PM inlet overheating point	If the PM inlet temperature is greater than this value, an alarm will be triggered	0 ~ 255 °C	80 °C	
PM outlet overheating point	If the PM outlet temperature is greater than this value, an alarm will be triggered	0 ~ 255 °C	93 °C	
Busbar Lv1 overheating point	If the temperature of the busbar is greater than this value, LV1 alarm will occur. And the charging power will decrease	0 ~ 6553 °C	90 °C	
Busbar Lv2 overheating point	If the temperature of the busbar is greater than this value, LV2 alarm will occur. And the charging will stop	0 ~ 6553 °C	120 °C	
Temperature alarm hysteresis	When an over temperature alarm occurs, the alarm will only disappear if the temperature drops below the hysteresis value	0 ~ 255 °C	5 °C	
Busbar overheating current period	When the LV1 over temperature alarm of the busbar occurs, the cycle time of current limiting.	0 ~ 255 Min	5 Min	
Busbar overheating current percent	When the LV1 over temperature alarm of the busbar occurs, the percentage of current limiting.	0 ~ 100 %	80 %	
Cooling Devices Type	Cooling method of power cabinet	Water Cooling \	Air Cooling	
		Air Cooling		
AC Input Power Limit	System total AC power limit value.	0 ~ 65535 KW	10000 KW	
Cabinet Fan Min Speed	Minimum speed of rotation for power cabinet fan	0 ~ 100 %	25 %	
Cabinet Fan Max Speed	Maximum speed of rotation for power cabinet fan	0 ~ 100 %	100 %	
Power Cabinet Fan Min Speed Temperature	The starting temperature of the power cabinet fan	0 ~ 255 °C	40 °C	
Power Cabinet Fan Full Speed Temperature	There is a linear relationship between temperature and fan speed, and at this temperature, the fan speed will reach its maximum	0 ~ 255 °C	70 °C	

Busbar Temperature Sensor Install	Is the temperature sampling sensor of the busbar installed?	Not Install\ Install	Not Install	
AC Input Single	Is it a single AC input? If it is No, then the AC input is dual channel	No \ Yes	No	
PDU Inner Ring Enable	Installation Enable for Inner Ring Contactor of Power Distribution Unit	No \ Yes	No	
System Efficiency Setting	Assumed value of system efficiency. This value can be used to calculate the total available power on the DC side	0 ~ 100 %	93 %	
Air cooled PC Outlet Over Temperature Lv1	LV1 overheating point at the outlet of the power cabinet. If the temperature at the outlet of the power cabinet exceeds this value, the system will run at reduced power and alarm.	0 ~ 120 °C	90 °C	
Air cooled PC Outlet Over Temperature Lv2	LV2 overheating point at the outlet of the power cabinet. If the temperature at the outlet of the power cabinet exceeds this value, the system will become unavailable and alarm.	0 ~ 120 °C	100 °C	

- 7. “Param Set” ->“AC Cabinet” ->“AC Cube Setting” -> “AC Meter Enable”

[AC Cabinet](#)



AC Cube Setting [Edit](#)

IMEU2 Device Type

- If the system is installed with an AC input meter, this value should be set to enable.

- 8. “Param Set” ->“AC Cabinet” ->“AC Contactor Setting”

AC Contactor Setting		Set	Cancel
AC Contactor Total Number	<input type="text" value="2"/>	1#PM Group AC Input Contactor	<input type="text" value="1"/>
2#PM Group AC Input Contactor	<input type="text" value="1"/>	3#PM Group AC Input Contactor	<input type="text" value="1"/>
4#PM Group AC Input Contactor	<input type="text" value="1"/>	5#PM Group AC Input Contactor	<input type="text" value="2"/>
6#PM Group AC Input Contactor	<input type="text" value="2"/>	7#PM Group AC Input Contactor	<input type="text" value="2"/>
8#PM Group AC Input Contactor	<input type="text" value="2"/>	9#PM Group AC Input Contactor	<input type="text" value="0"/>
10#PM Group AC Input Contactor	<input type="text" value="0"/>	11#PM Group AC Input Contactor	<input type="text" value="0"/>
12#PM Group AC Input Contactor	<input type="text" value="0"/>	13#PM Group AC Input Contactor	<input type="text" value="0"/>
14#PM Group AC Input Contactor	<input type="text" value="0"/>	15#PM Group AC Input Contactor	<input type="text" value="0"/>
16#PM Group AC Input Contactor	<input type="text" value="0"/>		

- 'AC Contactor Total Number' is set to the actual number of AC contactors installed in the system. Next is the mapping relationship table between power module and AC input contactors. Non-existent power module groups write 0.
- Example: Standard ICE-360/480 Power Cabinet has 16 total Power Modules configured into 8 Groups of 2 and has 2 AC Input Contactors. Groups 1-4 are connected to the #1 AC Input Contactor, and Groups 5-8 are connected to the #2 AC Input Contactor. The settings required for proper operation are shown in the above image.

8.3) Reset and Test

8.3.1) System Self Check

- Ensure there are no vehicles connected to the charger and all charging cables are in their proper holsters. Close and lock all the equipment doors except for the Power Cabinet. Enter the PC-Upper Controller webpage (192.168.1.100) and initiate a system Self Check by going to **Manual Ctrl → PCU → Start System Self Check**.

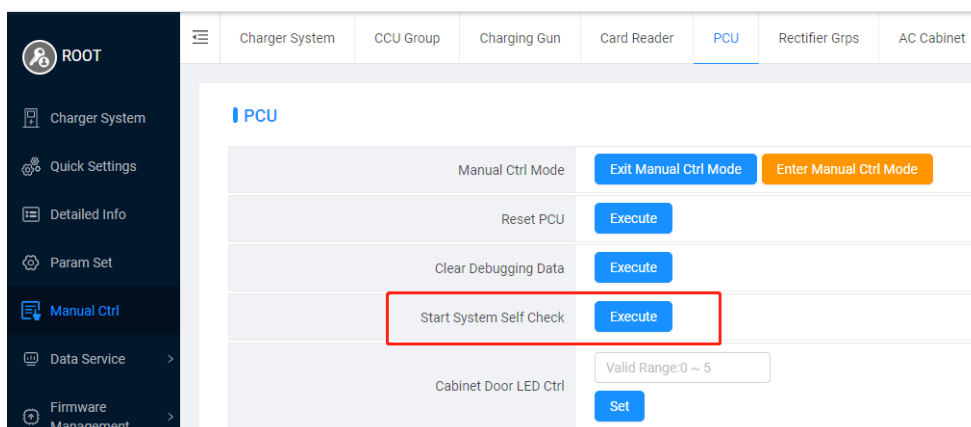

- Pay attention to safety during the Self Check. After the Self Check starts, the power modules and contactors will perform a series of sequential actions until the end; The process takes about a few minutes. If the Self Check passes, there will be no alarms. If the Self Check does not pass, an alarm will prompt which items have not passed. Address the alarms as necessary.

9.) Description of Relevant Parameters

- The important setting parameters of the power cabinet and liquid-cooled charging terminal of the split charging system are described in the following table:
- input User Level and Password: Root

NO.	Parameter name	Default parameters	Remarks
1	CCU Work Mode	There is a dial switch on the back side of Pilot controller, which corresponds to terminal address # 1 or # 2...	At the same time, it also needs to correspond to the network TCP # address on the billing unit.
2	Liquid-cooled Connector Installing type	One dispenser can support up to one liquid cooling connector and can choose no/A gun or /B gun.	Select the connector installation position, and the corresponding 485 (# 1 or # 2) bus of the pilot controller will communicate with the IMEU2. Consistent with the system wiring.
3	Liquid-Bump Max Speed	Default maximum 50%	The pilot controller is sent to the IMEU2 board via RS485
4	Fan Speed Limit (Aux)	Default 100%	The small fan on the top side of the dispenser is used for cooling in the cabinet and running during charging.
5	Power Cabinet System Fan Full Speed Temperature	Default 131 F (55°C)	Pilot controller sent to IMEU2 offline via CAN
6	Power Cabinet System Fan Start up Temperature	Default 113 F (45°C)	Pilot controller sent to IMEU2 offline via CAN
7	Power Cabinet System Fan Startup Speed	40%	Starting speed of fan of power Cabinet system
8	Fan Speed Limit	100%	Power Cabinet system fan full speed limit.
9	Liquid-Bump Max Speed	100%	Max speed of liquid cooling unit oil pump
10	Liquid-Bump Startup Speed	20%	When the oil pump of the liquid cooling unit starts slowly, the initial speed.
11	Ring Nodes Total(connector)	Default 4	Note that it is actually consistent with the number of groups of modules. Even if there are only two guns, if there are four groups of modules, it needs to be set to 4.
12	Liquid Pump Full Sped Start up Temperature	Default 95 F (35°C)	The oil pump reaches the maximum speed when the oil temperature exceeds 35 degrees.

13	Liquid Pump Work Duration at Low Temperature	Default 1 min	Time to prevent solidification disturbance when oil temperature is too low.
14	Liquid Pump Pause Duration at Low Temperature	Default 2 min	
15	Max Output Current when liquid oil is in: Low Temp temperature	Default 300A	
16	When Gun Temp Over this point, act as Normal Gun	Default 149 F (65°C)	
17	Max Output Current when act as Normal Gun	Default 100A	
18	Cool Source EnvTemp High Point	Default 122 F (50°C)	
19	Cool Source EnvTemp Low Point	Default -13 F(-25°C)	
20	Liquid Oil High Pressure Alarm Point	Default 0.9Mpa	
21	Connector Over Temperature	Default 185 F (85°C)	
22	Connector Ultra Temperature	Default 203 F (95°C)	
23	Conn Recover from OverTemp Point	Default 149 F (65°C)	
24	Pressure Meter Range	Default 16	
25	Motor Pole Pair	Default 4	
26	Power Cabinet AC input Channels	Default 2	

10.) Power Distribution Strategy

10.1) Introduction to Power Nodes

- Each group of power modules is referred to as a node, corresponding to a charging gun (if the node is not connected to a charging gun externally, the node only performs power switching).
- When charging begins, only the node corresponding to the charging gun provides output power. The node outputs power according to the demand of the dispenser. When the dispenser requests an increase in power, the node searches for available sub-nodes to parallelize with. When there is excess charging power, the root node will search for end-terminal sub-nodes and exit the parallelization.

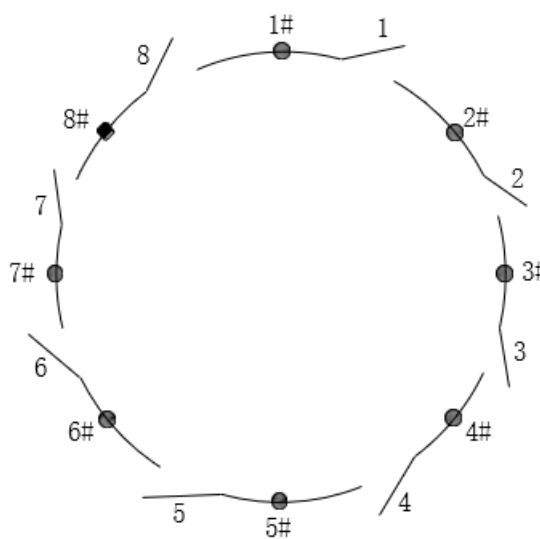

- Using an 8-node system as an example, each node is connected to adjacent nodes on the left, right, and inside.

10.2) Scenario 1: Increasing Charging Power

- Node 1's left node is Node 8; its right node is Node 2.
- Node 1 serves as the root node for charging. When the dispenser requests an increase in charging power, Node 1 will select Node 8 (left) as a sub-node. If the dispenser requests another power increase, Node 1 will select Node 2 (right) as a sub-node. If, in this situation, the dispenser still requires a further increase in charging power, Node 1 will go through Node 8 (left of Node 1) to select Node 7 (left of Node 8) as a sub-node.
- Therefore, when there is a need to increase the charging power during the charging process, the root node will sequentially increase the power by selecting the left node, then the right node.
- If a node is found during the search process, but it is not an idle node (e.g., currently charging, charging as a child node, or experiencing a malfunction), then the algorithm will skip that node and continue searching for other available nodes. The goal is to find a suitable, idle node that can meet the charging requirements.

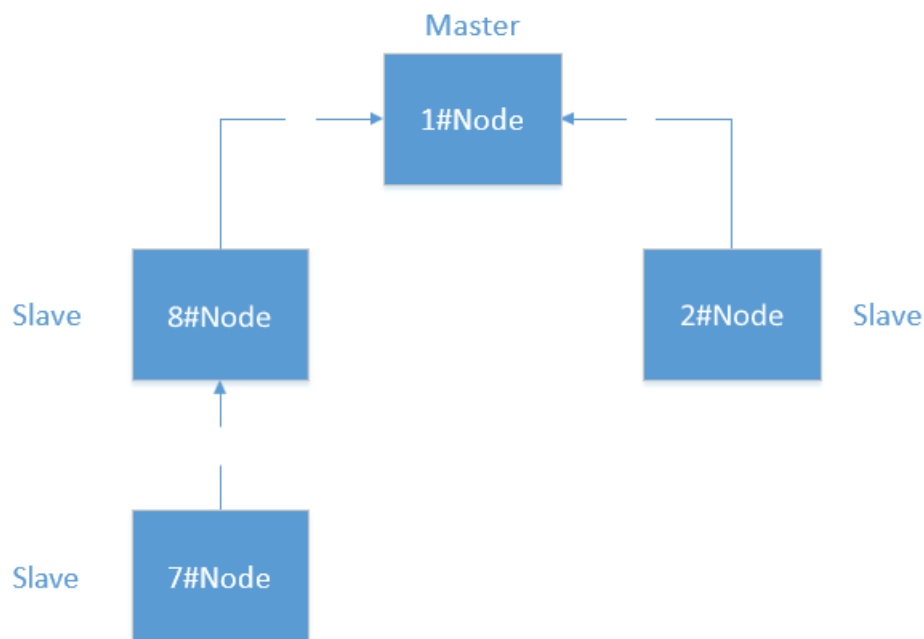
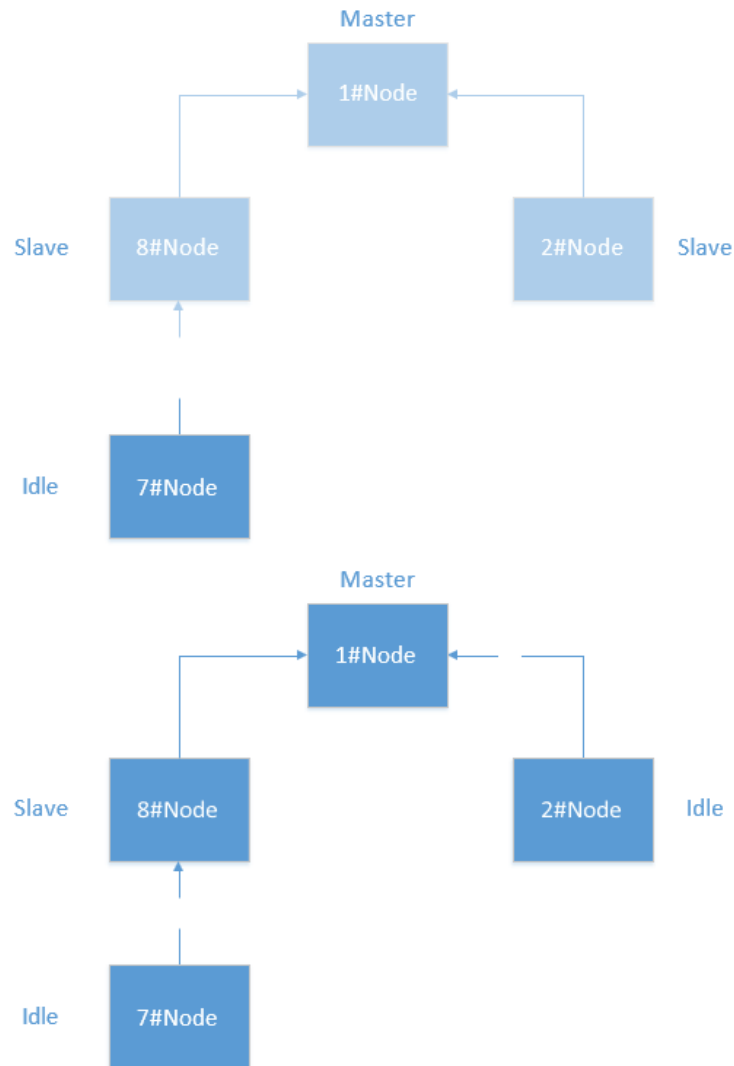

Figure 10.1 The order in which the root node searches for child nodes is 1 -> 2 ->3

10.3) Scenario 2: Decreasing Charging Power

- When the required power decreases and remains below the current root node's maximum charging output power minus the maximum output power of the furthest end-terminal child node for a continuous duration of 60 seconds, the power allocation for the end-terminal node will be terminated.
- Using the example provided:
 - Node 1 is the root node and nodes 8, 2, and 7 are the child nodes. In this case, the maximum output power of the root node is the sum of the maximum output power of nodes 1, 8, 2, and 7. Since node 7 is the furthest terminal node, when the charging power is lower than the difference between the maximum output power of the root node and the maximum output power of node 7, and this situation persists for 60 seconds, node 7 exits and becomes idle. In this case, nodes 8 and 2 become the new terminal child nodes.
- When the charging power decreases further and the child node exits for 60 consecutive seconds, the root node exits from the node with the lowest power (for example, the maximum power of node 8 is 80 kW, and the maximum power of node 2 is 40kw, then node 2 exits).



- As shown in the diagram, when the required power decreases and meets the conditions for the furthest end-terminal node (node 7) to exit for a continuous duration of 60 seconds, it will be prioritized for termination. Then, as the required power decreases further, with the new end-terminal nodes being 8 and 2, the node with the lowest output power will be prioritized for termination.

10.4) Scenario 3: Charging Initiated at Node Along the Power Path

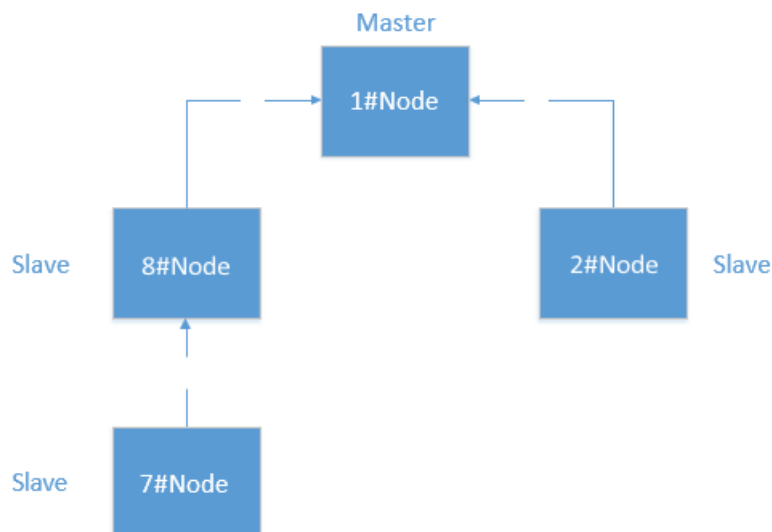

- In this scenario, Node 1 serves as the root node, and Nodes 8, 2, and 7 serve as child nodes. Here, Node 8 initiates charging through its corresponding charging gun. As a result, Node 8 and all its child nodes will exit the charging process and become idle nodes. Node 8 will then function as a new root node, providing output power to the corresponding charging gun.

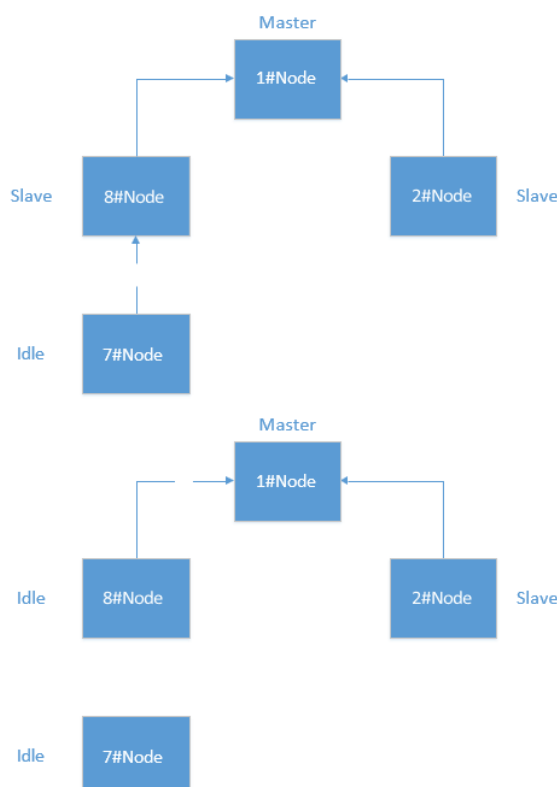

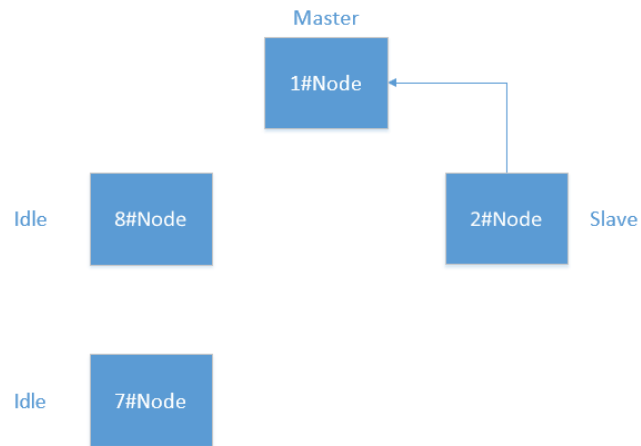

- In this situation, if the charging power is insufficient, root node 1 will look down for a new child node through its right child node 2. When the charging power of root node 8 is insufficient, it will search for child nodes through node 7 on its left side, which is the same as scenario 1.

11.) User Operation

- The ICE-360/480 operation depends on its output connections: CCS or CHAdeMO. During the charging process, the Human Machine Interface (HMI), will give instructions and will signal different stages. These sequences are shown in this section.

11.1) Output Connector

- The ICE-360/480 is prepared to charge electric vehicles according to the charging systems mentioned. **Notes:** There is a coolant pipe inside the liquid cooling connector.
- CCS liquid cooling connector: Bending of the cable should be minimized to prevent restriction of the liquid coolant within the cable.
- See section 6.2 for more details

11.1.1) CCS1 and NACS Connector

	<p>CCS1 Combined Charging System Natural cooling</p>	
	<p>CCS1 Combined Charging System Liquid cooling</p>	<p>CCS1 Connector Handling</p>
	<p>NACS Combined Charging System Natural cooling</p>	

11.2) Operation Instructions

- When the user starts the operation on the charging dispenser, if all output connections are idle or the device allows DC charging, the HMI display will display the following screen:

CCS1+CCS1 Units

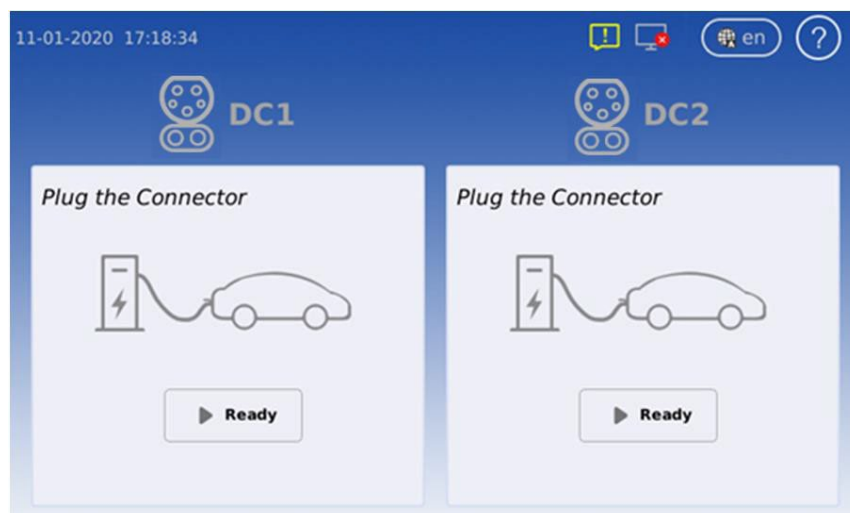

- Charging Steps
 - Plug the charging connector into the vehicle interface. UI main page display connector has "Plugged". Click "→Start" Button.

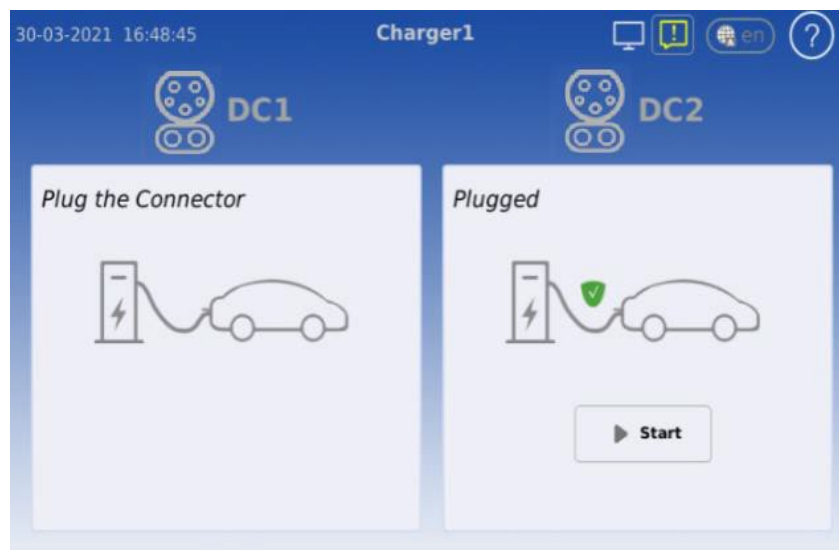

- Swipe the RFID or scan QR Code or use OTP by inputting the password to start the charging.



- Select Auto/Time/SOC/KWh charging strategy (Optional)

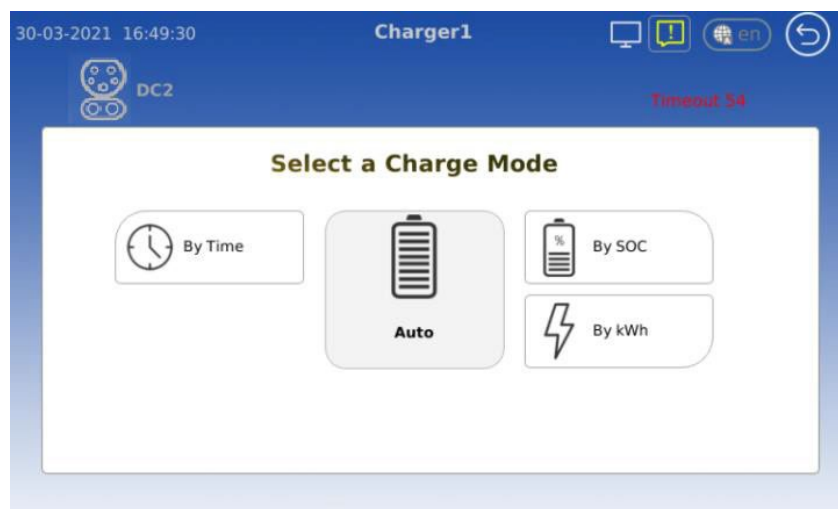

- On Waiting Start Charge.

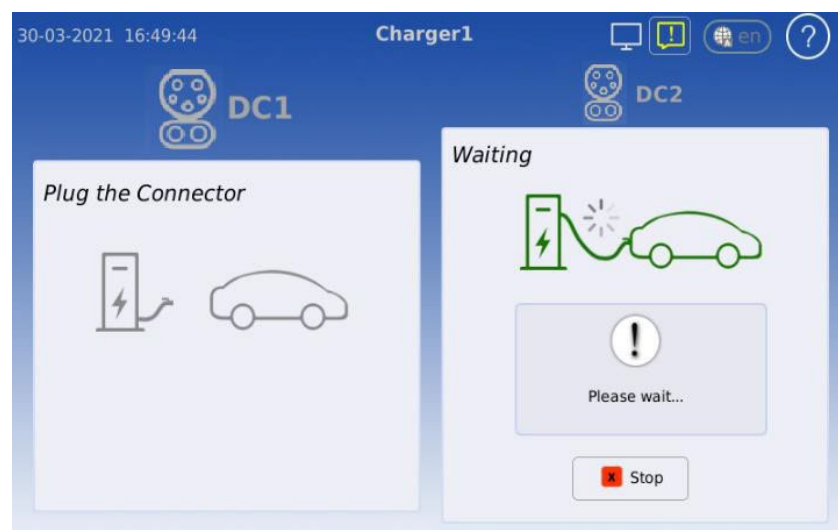

- On Charging

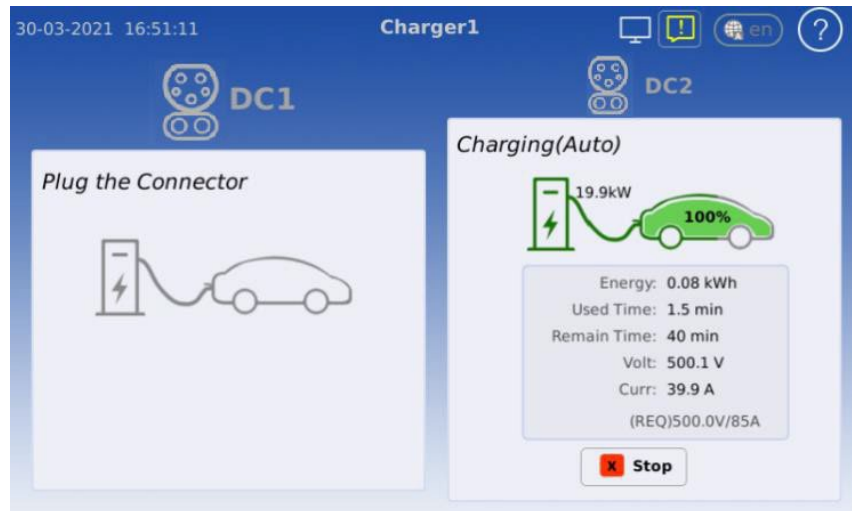

- After the vehicle is fully charged, stop charging first, then unplug the charging connector.

11.3) Ethernet and OCPP Setting

- There are 2 standard parameters for back-end setting. Please get them from the back-end supplier.
 - Charger ID
 - OCPP Server End URL

Example 1: for a charge point with identity “CP001” connecting to a Central System with OCPP-J endpoint URL “ws://centralsystem.example.com/ocpp” this would give the following connection URL:

ws://centralsystem.example.com/ocpp/CP001

Figure 11.1 Example of OCPP-J 1.6 Spec

- **Notes:** The protocol upper controller supports OCPP-J 1.6 and 2.0.1. Please refer to the OCPP official documents if you have any questions about the above 2 parameters or the protocol itself.

11.3.1) Connection Check

- If the above settings are done properly, you should see the  icon on screen (without reboot).
- Check the OCPP Platform for proper communication of the charger. Seeing the icon on the display screen only shows the charger is connected to the system but does not show the system sees the charger properly.

11.4) Network Setting

11.4.1) Router Set Up

This guide is intended to help configure the main Cellular Router inside the Power Cabinet for external communication. Log into the SSID of the router via the web browser.

- Click on “Devices” enter in the MAC address of the router that needs to be configured. Click on the device and it will bring you to the device page. If logging in via SSID you can skip this step.

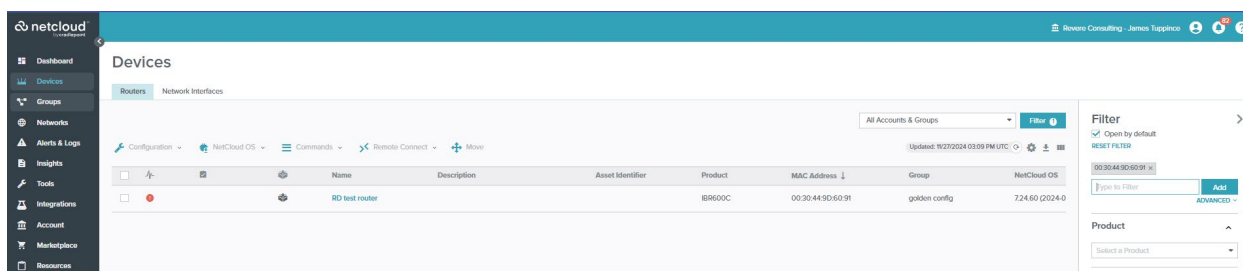

- On the Device page click on “Configuration” then “Edit”. Drag Ethernet to the top of the list of “WAN Device Interface Profiles & Priority”.

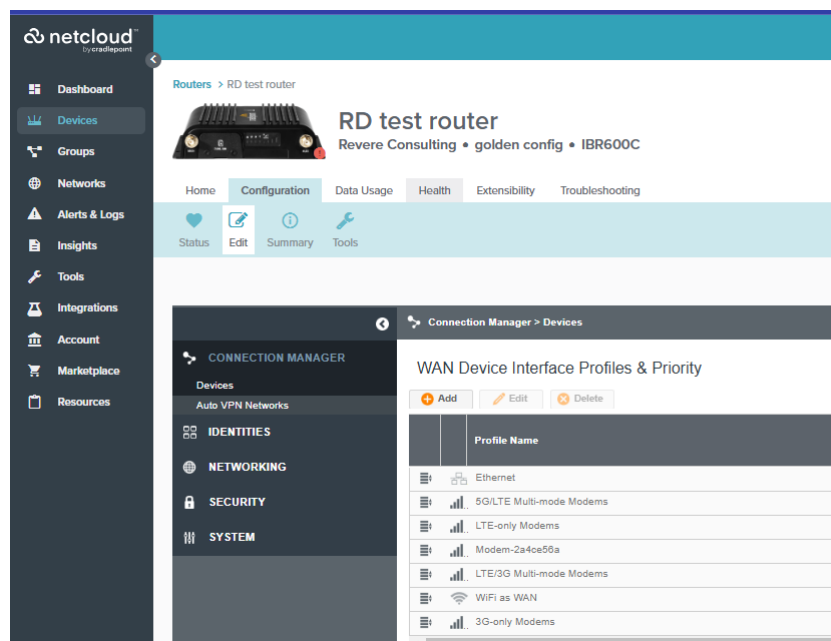

- Once “Ethernet” is at the top of the list, under Connection Manager click on “Networking” and in the sub tab click “Local IP Networks”. Click on the first option check box and hit “Edit.”

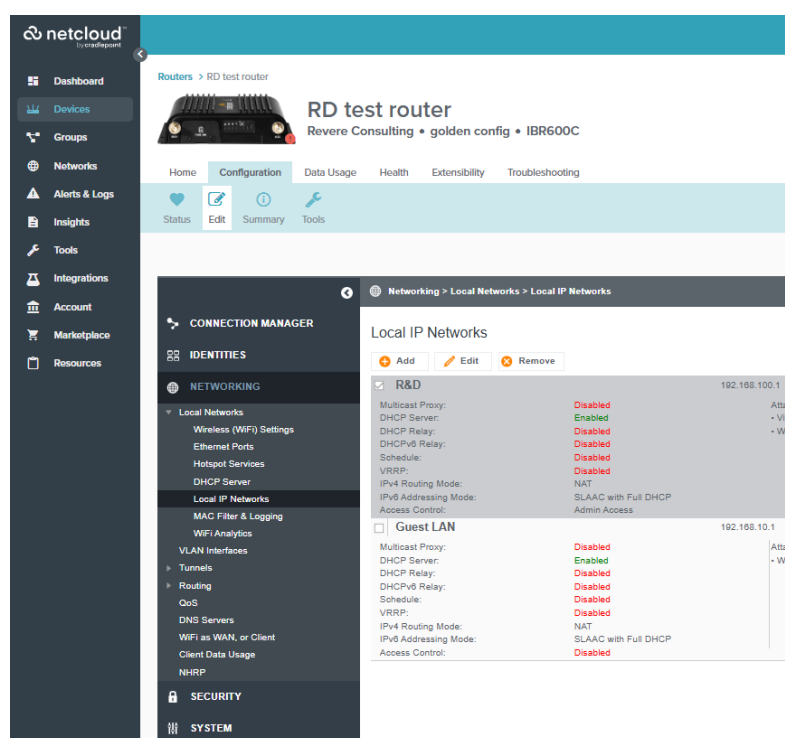

- Click on “IPv4 settings” and make sure the IP address is the correct scheme needed for the Ice cube. This will ensure that all dispensers can properly communicate locally and externally to InControl. The IP address should be changed to 192.168.1.1.

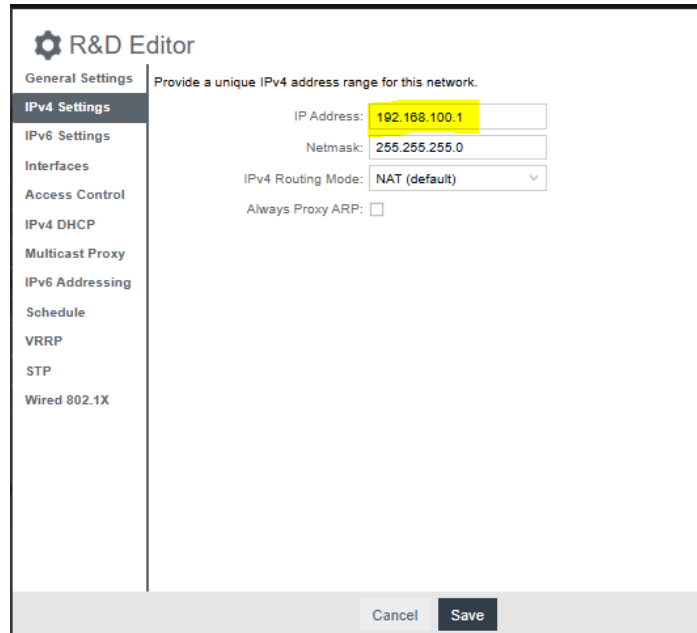

The screenshot shows the 'R&D Editor' interface with the 'IPv4 Settings' tab selected. The main content area is titled 'Provide a unique IPv4 address range for this network.' and contains the following fields:

- IP Address: 192.168.100.1
- Netmask: 255.255.255.0
- IPv4 Routing Mode: NAT (default)
- Always Proxy ARP:

At the bottom of the screen, there are 'Cancel' and 'Save' buttons.

- Hit “save” then hit “Commit” at the bottom of the screen to update the router configurations.

11.4.2) Wireless Network Configuration

- First, check if your system is equipped with an external wireless router.
- This router is installed inside the Power Cabinet and is interconnected with the Network Switch with a RJ45 network cable. The router is usually pre-installed along with the charger before leaving the factory, therefore the only thing needed to ensure it is operating properly.

11.4.3) Wired Network Configuration

- First, check if your system is equipped with an external wireless router.
- Connect the customer ethernet cable from their router LAN port to the WAN port of the Cradlepoint.

11.5) Charger Software Update

- The charger can update the firmware through OCPP or OEM backend remotely, or local update through USB drive to update the firmware of the upper controller and pilot controller.
- The following figure 11.2 software version is for reference only, the actual situation shall prevail.

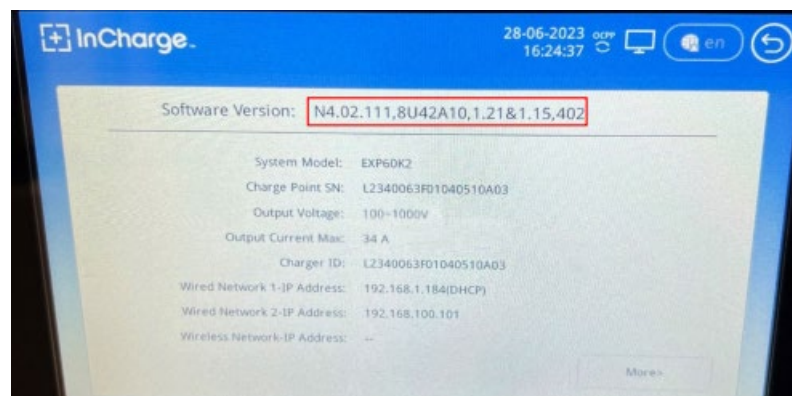

Figure 11.2 Software Version

- **CAUTION:** It is imperative that the correct firmware be installed into each component. If the incorrect firmware for a component is installed, the component may require replacement and full reprogramming prior to operating properly. Please contact InCharge Support for assistance.

11.5.1) Upper Controller Update

- For upper controller's update, firstly power on the controller, and then plug the USB drive into the controller's USB inlet, and then go into the setting in "Manual Ctrl" --> "Charger System" --> "Reboot System", need to input "Soft Reset", and waiting the automatic update finish, and then take off the USB disk. Check the software version as shown in Figure 11.2.

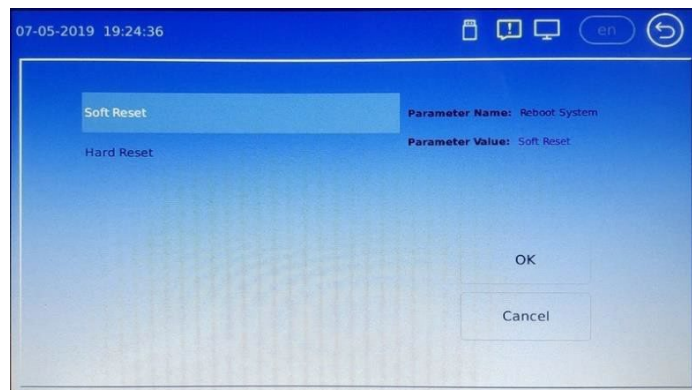
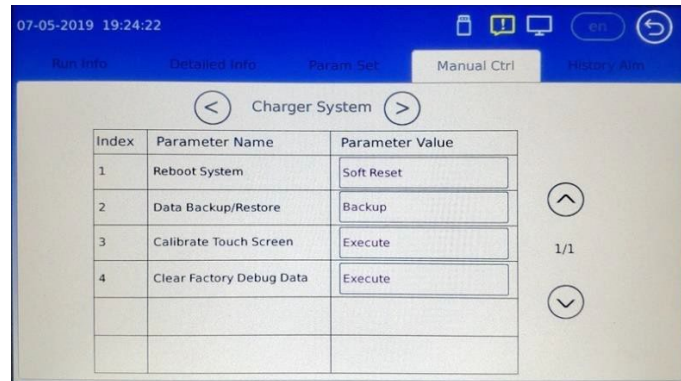

Figure 11.2 Software Version

11.5.2) Pilot Controller Update

- For pilot controller's update, firstly power on the controller, and then plug the USB disk into the controller's USB inlet. Then restart the system (disconnect the auxiliary switch, then close it again). Pay attention to the sound. After hearing three beeps, it means the upgrade is complete. You can pull out the USB drive. Check the software version as shown in Figure 11.3.



Figure 11.3 Software Version

Appendix 1) Engineering and Technical Parameters

- The Power Cabinet has a front and back door. At least 39.37 inches (1000mm) of clearance should be left on both sides to provide space for maintenance.
- The Power Cabinet has front and back exhaust heat and ventilation. A clearance of at least 39.37 in (1000mm) must be provided to prevent hot air recirculation back to the inlet.
- **Note: While the system is running, the temperature of the back door will be hot. Avoid touching by hand.**

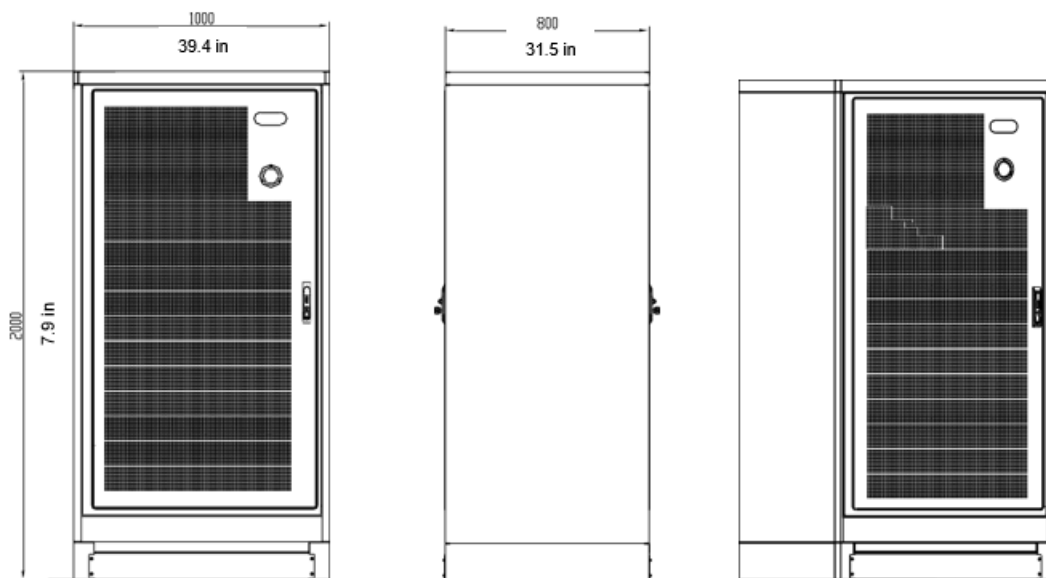

Power Cabinet Three Views

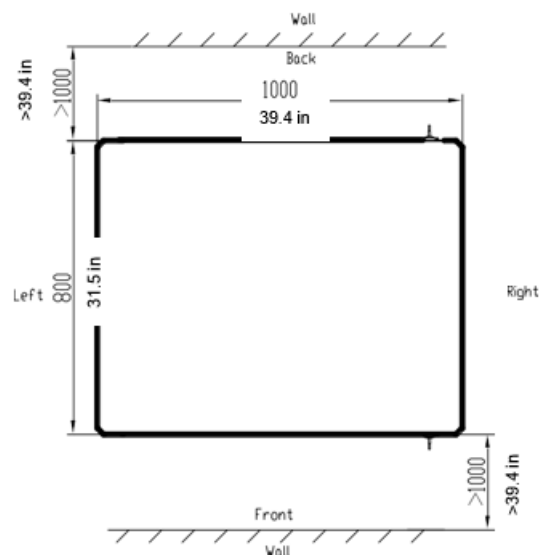

Power Cabinet Space Requirement

- The Slim Line Dispenser is reliable for wall installation, but it is recommended to leave at least 39.47 in (1000mm) distance. The front door should have a gap of at least 39.47 in (1000mm) to provide maintenance space.
- The Charging Dispenser has a right-side air inlet and a left side air outlet. A minimum gap of 39.47 in (1000mm) should be provided to prevent hot air from flowing back into the inlet.

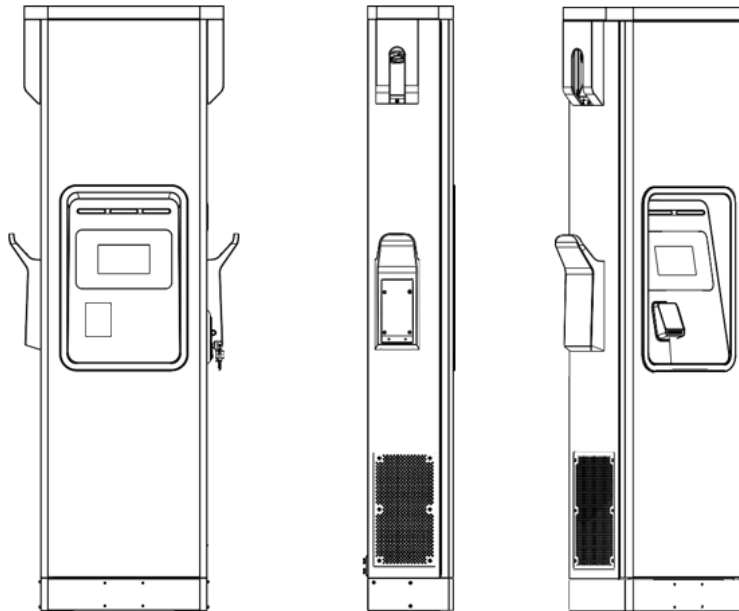

Slim Line Dispenser Three Views

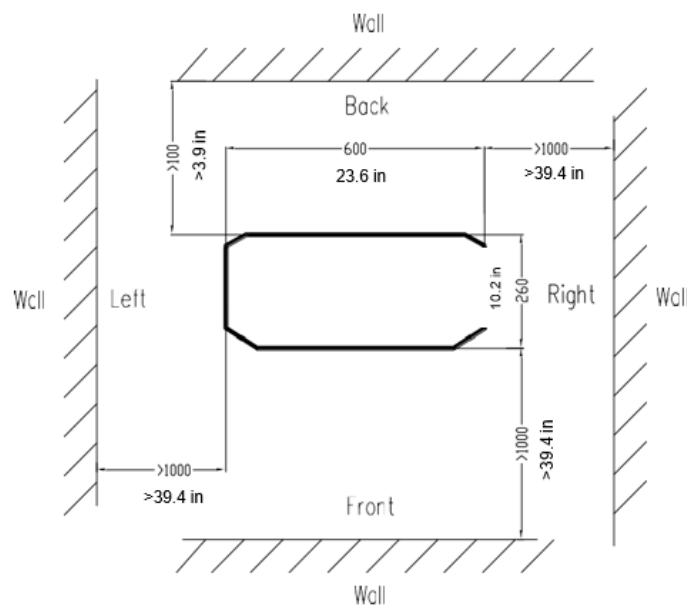

Slim Line Dispenser Spacing Requirements

The Micro Dispenser is reliable for Wall installation. The front door should have a gap of at least 23.62in (600mm)

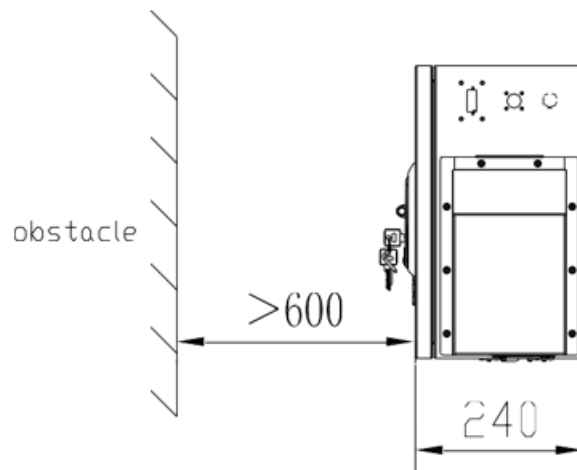
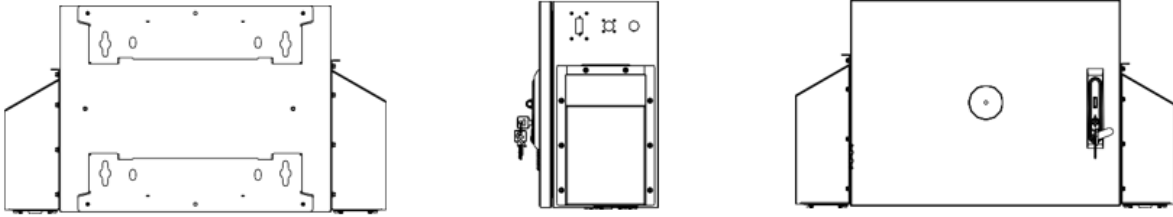

Micro Dispenser Space Requirements

Appendix 2) System Electrical Connection Diagram

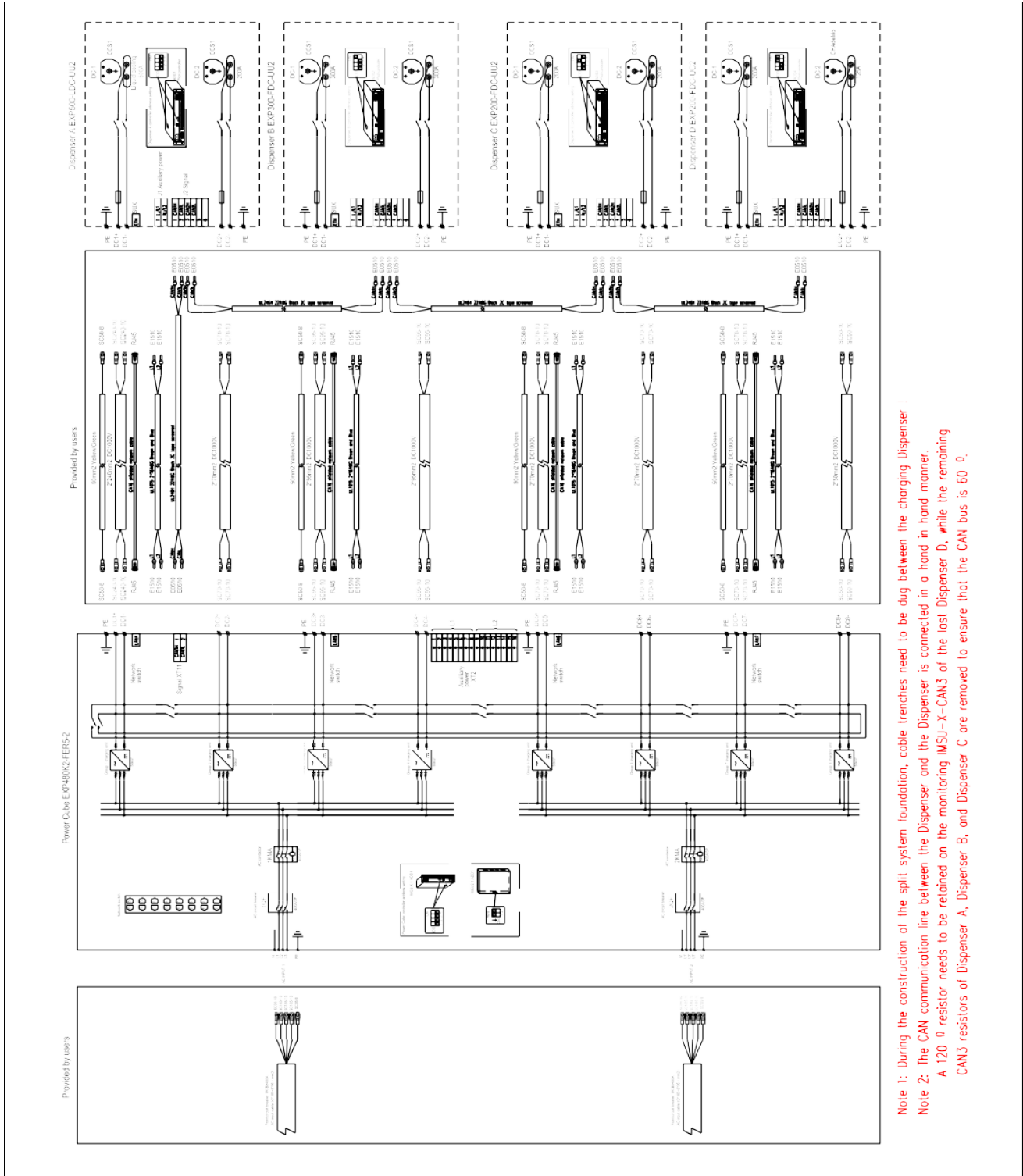

Note 1: During the construction of the split system foundation, cable trenches need to be dug between the charging Dispenser
Note 2: The CAN communication line between the Dispenser and the Dispenser is connected in a hand in hand manner.
 A 120 Ω resistor needs to be retained on the monitoring IMSU-X-CAN3 of the last Dispenser D, while the remaining
 CAN3 resistors of Dispenser A, Dispenser B, and Dispenser C are removed to ensure that the CAN bus is 60 Ω.

Attachment 2:

Method for removing CAN3 120 Ω Resistor from IMSU-X Monitoring

- Step 1: Unscrew the two screws on the left and right sides of the upper part of the IMSU-X monitoring board, and the upper monitoring board can be pulled out, as shown in the following figure

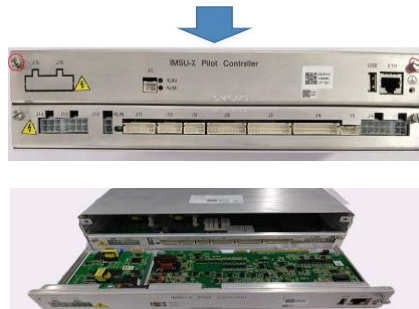

- Step 2: Find the matching resistor jumper cap on the monitoring board, as shown in the following figure.

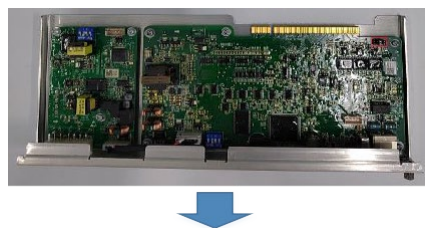

- Step 3: Both jumper caps need to be changed from PIN 1 and 2 (with 120 Ω) to PIN 2 and 3 (without 120 Ω), as shown in the left and right figures.

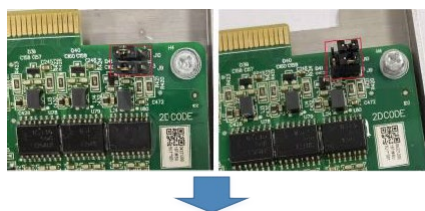

- Step 4: Insert the upper control board back in and tighten the two fixing screws.

Micro Dispenser Electrical Connection Diagram

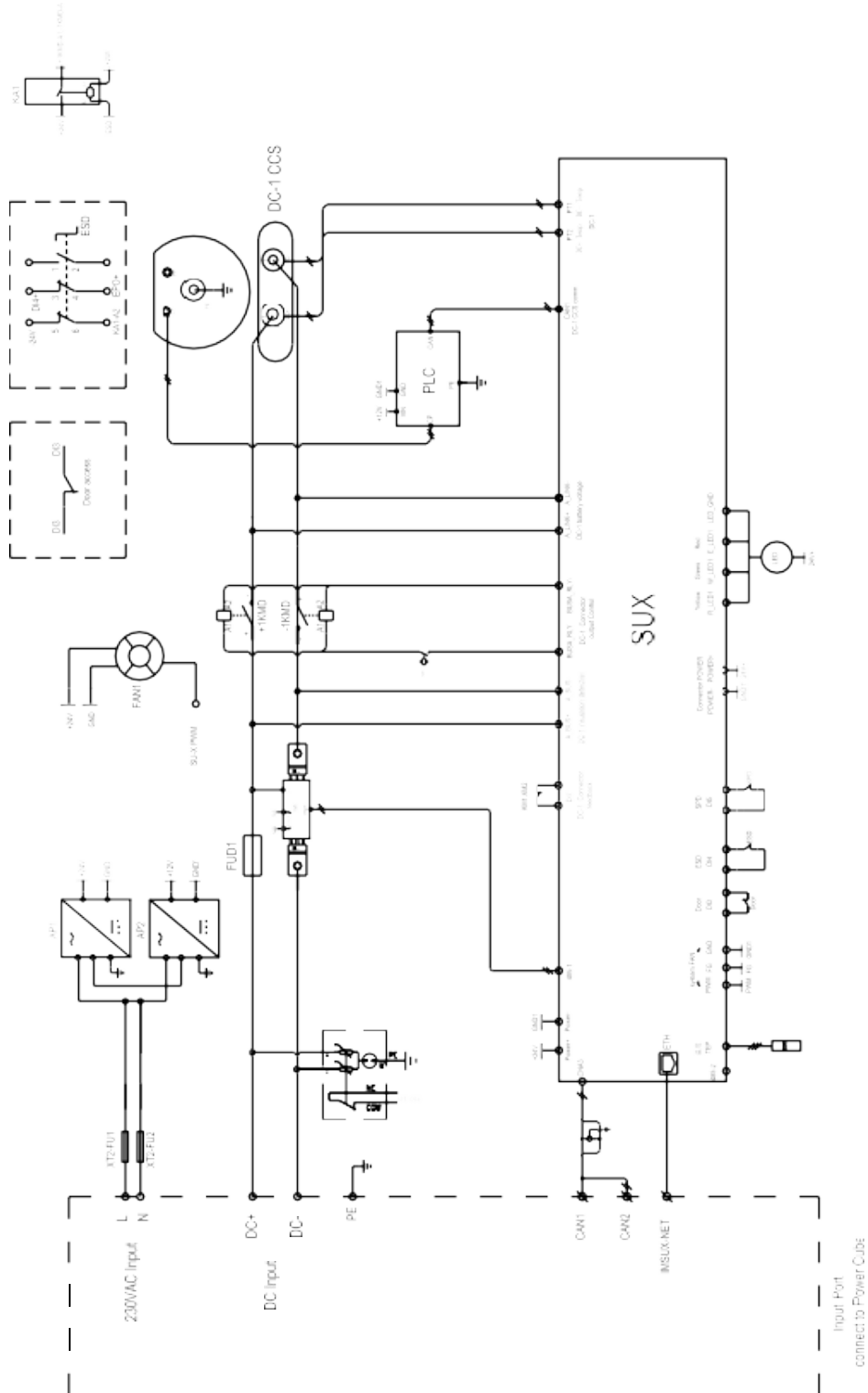

Appendix 3) Maintenance

1.) Maintenance Table

NO.	Position	Method	Tool	Maintenance cycle
1	AC input main breaker	Eyes check	/	2 months
2	Devices and connection points Main circuit devices (circuit breaker, AC contactor, DC contactor, DC fuse), copper bar, power module connector	Sound and Eyes check	Torque wrench	2 months
3	AC SPD	Eyes check	/	3 months
4	Charging plug	Eyes check	Brush	Daily
5	Cooling Fan and Filter cotton	Eyes check	Blower, Screwdriver Soft Brush Vacuum Cleaner	3~6 months
6	ESD	Eyes check	/	Daily
7	Alarm information check	Eyes check	/	Daily
8	Check all electrical connections	Sound and Eyes Check	Torque Wrench	12~24 months

2.) Maintenance Operation

2.1) AC Input Main Breaker

- When the circuit breaker is in the closing state, press the insulation test knob or trip test button to test the insulation function or trip function of the circuit breaker.
- After the circuit breaker is released, the recovery method is as follows: first, turn the circuit breaker to the switch off state; then, turn it to the switch on state.





400A Frame

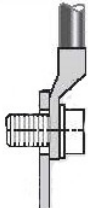

2.2) Devices and Connection Points

- Check the connection points (circle in the picture) between the main circuit components (circuit breaker, AC contactor, DC contactor, fuse) and copper bar or cable, the connection points between copper bar and copper bar, and the connector of power module for burns or serious discoloration. If any are seen, please check the torque and connection according to point 2) and replace the damaged cable.
- Check whether the screw fixing torque mark is normal. If there is any deviation, please re-torque with a torque wrench and mark with a marker.

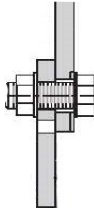
Types of connection points and similar structures		
Type A	Type B	Type C
		

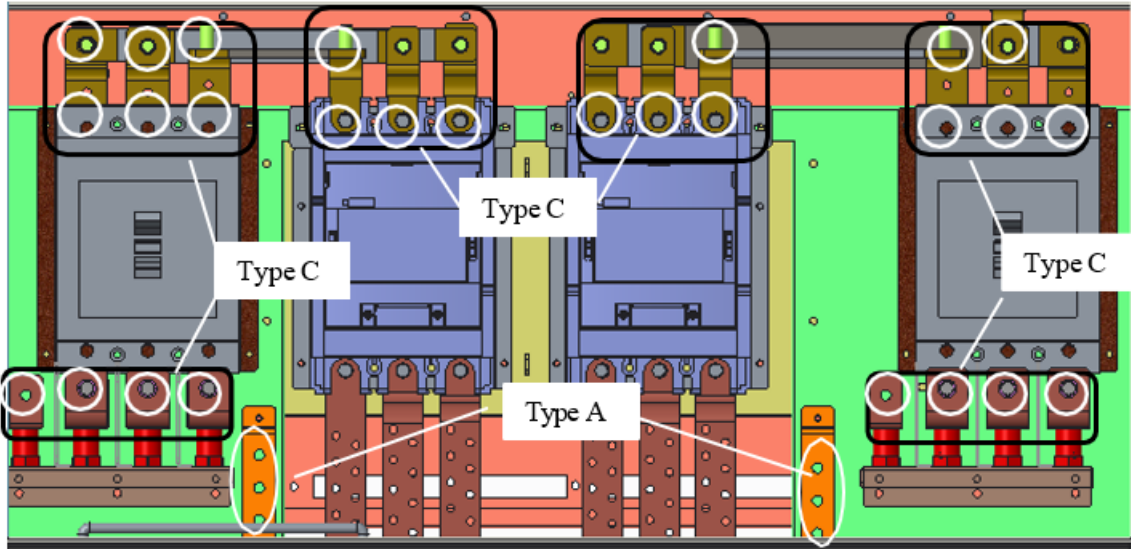

AC input side of Power Cabinet

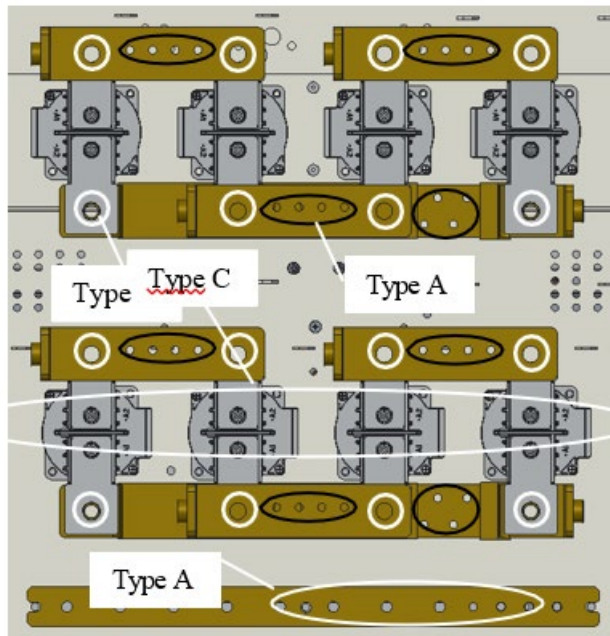

DC output side of Power Cabinet

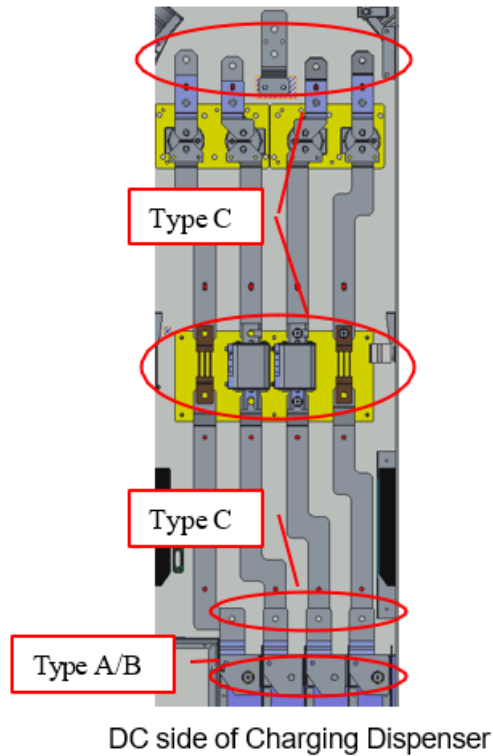

2.3) AC SPD

- Check the status window of SPD. If the window color changes from green to red, it indicates that SPD has been damaged, and the manufacturer will need to be contacted for replacement.

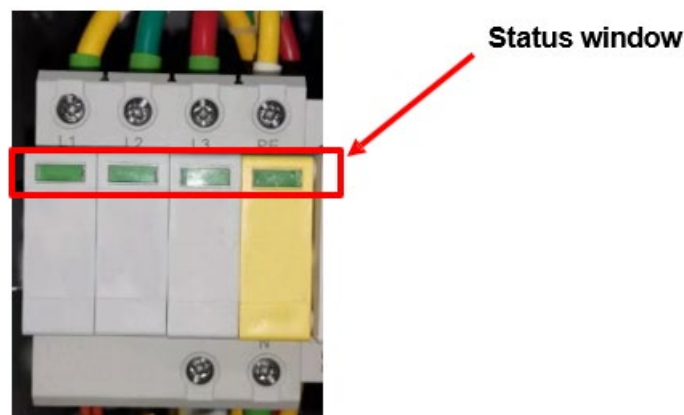

2.4) Charging Plug

- Check whether the charging plug is cracked or damaged. If so, please contact the manufacturer.
- Check whether the DC + and - terminals of the charging plug have obvious burning marks. If so, please contact the manufacturer for treatment.
- Use a brush to remove the dust on the surface of DC + and - terminals.

CCS1

DC+ and DC- terminals

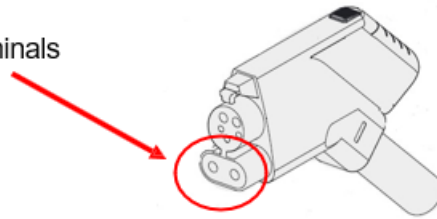

CCS1 (Liquid cooling)

DC+ and DC- terminals

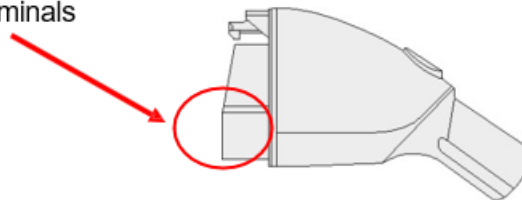

2.5 Cooling Fan and Filter Cotton

- Check the dust screen on both sides of the heat exchanger for dust.
- Use the fan to clean the dust on the dustproof net.
- According to the site environment, the dust net shall be effectively removed at least once every three to six months, and it shall be replaced once a year at most.
- Remove the dust screen with a screwdriver, and use a soft brush, blower and vacuum cleaner to remove the dust effectively.
- Use vacuum cleaner and soft brush cloth to effectively remove the sundries and dust in the cabinet.



Power Cabinet dustproof net

2.6) ESD

- Check the emergency stop cover plate. If the cover plate is damaged, please contact the manufacturer for replacement.

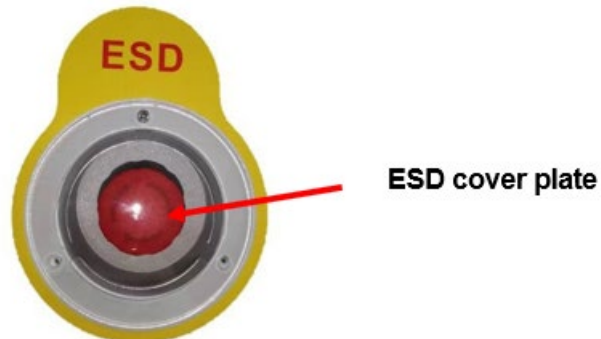

2.7) Alarm Information

- Click “?” In the upper right corner of the screen to view the alarm information.
- If there is alarm information, it should be handled immediately. If it cannot be handled, contact the manufacturer to handle.



Appendix 4) Error Codes and Possible Solutions

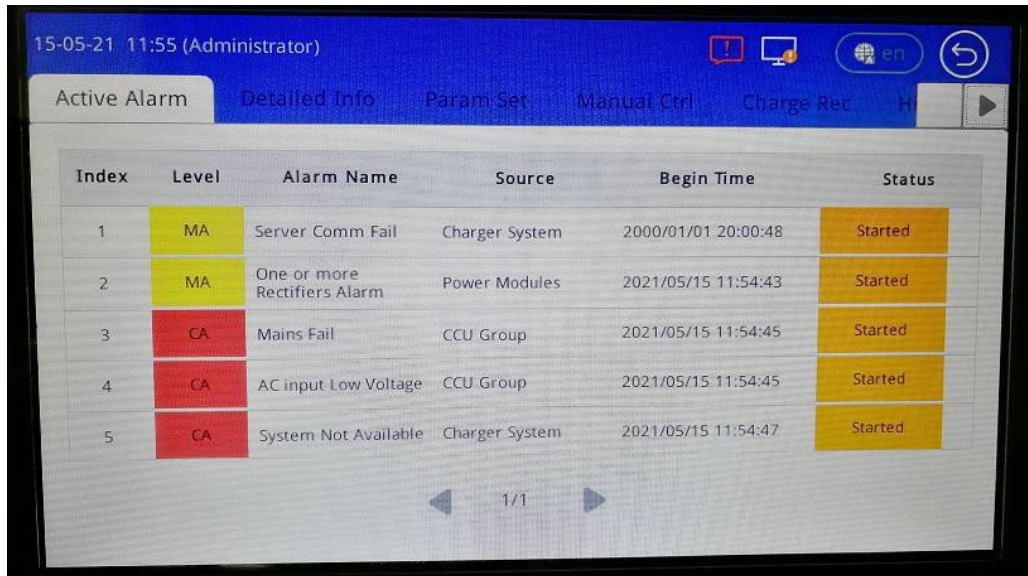

Index	Level	Alarm Name	Source	Begin Time	Status
1	MA	Server Comm Fail	Charger System	2000/01/01 20:00:48	Started
2	MA	One or more Rectifiers Alarm	Power Modules	2021/05/15 11:54:43	Started
3	CA	Mains Fail	CCU Group	2021/05/15 11:54:45	Started
4	CA	AC input Low Voltage	CCU Group	2021/05/15 11:54:45	Started
5	CA	System Not Available	Charger System	2021/05/15 11:54:47	Started

Table: Charger Alarms

NO.	Alarm ID	Alarm Name	Alarm Level	Description	Remark
1	1	System Not Available	CA	The system is out of service and charge is not allowed. This usually comes after other critical alarm (e.g. EPO pressed)	
2	2	System Disabled	MA	The system is out of service and charge is not allowed. This happens after system is set to 'In-operative' by service guy or back-end.	
3	4	Server Comm Fail	MA	Whether the network is not accessible or the connection between server and charger is broken. If the charger is supposed to be used offline this alarm can be ignored.	
4	5	All kWh Meter Not Installed	MA	All kWh meters are set to 'Not installed'. This means the system is not available. This alarm should not come with a normal charger unless you erased all the settings in controller Flash.	

5	6	CCU Comm Fail	CA	The communication between Upper controller and pilot controller failed. You need check the RS-232-2 connection to eliminate it.	
6	7	EPO is pressed	CA	This alarm appears after someone pressed the EPO. Please reset the EPO when nothing emergency is existed to eliminate it.	
7	8	Door is opened	CA	Door should be closed.	
8	9	SPD alarm	CA	Check the SPD device and replace it.	
9	10	Mains Fail Alarm	CA	Check AC mains and the related contactor.	
10	11	Connector is disabled	MA	The specified connector is out of service and not allowed to charge. This happens after the connector is set to 'In-operative' by service guy or backend.	Connector A/B shall be specified
11	12	System over temp	MA	The temperature measurement from sensor is over the high limit point (default is 75 'C)	Note that this alarm does not stop/prohibit charge function
12	13	All Rectifier Failure	CA	This means system not available. Please check the work status of the power modules and make sure they work properly	
13	14	All Rectifier Comm Fail	CA	This means system not available. Please check the CAN wiring between power modules and pilot controller.	
14	15	Rectifiers Failure	CA	This means the specified connector will not be available. Please check the work status of the specified group of power modules and make sure they work properly.	Rectifier group (Dispenser A/B) shall be specified
				This means the specified connector will not be available. Please check the CAN wiring between power modules and pilot	Rectifier group (Dispenser A/B) be specified

15	16	Rectifiers Comm Fail	CA	controller. Also, you may need check the dipswitches of the power module.	
16	17	Insulation Comm Fail	CA	This means the specified connector will not be available. Check the RS-485 wiring between insulation detector and pilot controller.	
17	18	Output Shorted	CA	This is from Rectifiers after detected the internal circuit shorted	
18	19	Insulation Alarm	CA	This is from pilot controller after detected the insulation abnormal.	
19	20	PLC ComFail Alarm	CA	This is from pilot controller when the PLC communication is lost.	
20	21	Ground Fault	CA	This is from pilot controller after detected ground fault.	
21	22	AC Fail Alarm(for AC only)	CA	This is from pilot controller after detected AC connector input fails (DI)	
22	24	One or more Rectifiers Alarm	CA	This means one or more power modules in system has failure and you need to check/repair them.	
23	25	IMEU2(Liquid Control) Comm Fail	CA	This means the controller of the liquid connector cooling system has lost communication (RS485) to pilot controller. (Note: this is for the liquid connector in split charger system only.)	
24	26	IMEU2(Power Control) Comm Fail	CA	This means the controller of power controlling (inside the power cabinet) has lost communication (CAN) to charger main controller. (Note: this is for the split charger system only.)	
25	27	Liquid Alarm-Pump Fail	CA	This means the pump has a failure in the liquid connector cooling system. (Note: this is for the liquid connector in split charger system only.)	

26	28	Liquid Alarm-High Temperature	MA	This means high temperature detected by liquid controller and the ongoing charging power will be derated. (Note: this is for the liquid connector in split charger system only.)	
27	29	Liquid Alarm-Over Temperature	CA	This means very-high-temperature detected by liquid controller and the ongoing charging will be derated or terminated. (Note: this is for the liquid connector in split charger system only.)	
28	30	Liquid Alarm-Temperature Sensor Fault	CA	This means the liquid controller detected that the temperature sensors have been all failed and the liquid connector may be disabled unless one of the sensors is recovered or repaired. (Note: this is for the liquid connector in split charger system only.)	
29	31	Liquid Alarm-Pump Pressure Abnormal	CA	This means the pump pressure has been detected as abnormal and the ongoing charging will be derated or terminated. (Note: this is for the liquid connector in split charger system only.)	
30	32	Liquid Alarm-Pump Oil Level Abnormal	CA	This means the pump oil level has been detected as abnormal and the ongoing charging will be derated or terminated. You need to check the oil. (Note: this is for the liquid connector in split charger system only.)	
31	33	AC input Over Voltage	CA	The AC mains voltage is higher than the max range which will cause the system run abnormally.	
32	34	AC input Low Voltage	CA	The AC mains voltage is lower than the min range which will cause the system run abnormally.	

33	36	CCU in Upgdate Process...	OA	This means the pilot controller is in upgrading process and system is temporarily disabled.	
34	301	CR CommFail	CA	Card Reader communication is failed. Check the RS-232 wiring between card reader and upper controller.	
35	401	kWhMeterCommFail	CA	The communication between upper controller and specified kWh meter is failed. This means the specified connector will be out of service and forbidden to charge. Please check the RS-485 wiring between the kWhMeter and upper controller.	
36	402	Sampled Invalid Current	CA	The measurement from the specified kWh meter is invalid. This usually happens with a reversed wiring for the current shunt.	
37	403	HeatExchangerCommFail	CA	The HeatExchanger is losing RS485 communication with Upper controller. This may be dangerous for the heatExchanger may have been physically damaged.	
38	404	U2 Comm Break	CA	There are two control boards, U1 and U2, inside the pilot controller, and their communication is abnormal. Please ensure that their control dial is correct and consistent, otherwise it may lead to charging failure	
39	405	Communication failure between CCU and PCU	CA	Communication failure between pilot controller and PCU, which may be due to abnormal CAN communication line connection or abnormal resistance value on the CAN bus (normally around 60 ohms)	

1. *CA* - Critical alarm *MA* - Major alarm *OA* - Observative Alarm

Stop Reason Classification	Code	Description	Remark
Normal Stop	1	Normal Stop	Condition satisfied
	2	EV Request Stop	EV Request Stop
Charger Error	201	Parameter configuration failed	
	202	Charging Enable timeout	
	203	Abnormal volt of outside bus	
	204	Unable lock charging connector	
	205	Insulation inspection abnormally	
	206	Insulation inspection timeout	
	207	EV Relay Pull-In timeout	
	208	Require Curr Timeout	
	209	Remain time over stop	
	210	Ring fail alarm (reserved)	
	211	Communication with EV failed	
	212	Plugged connector timeout	
	213	Pre-Charging fault	
	214	DoorOpen	
	215	EPO	
	216	SPD	
	217	AllRectFail	
	218	MainsFailAlm	
	219	AIRectCommFail	
	220	E_LockFail	
	221	ConnectorOverTemp	
	222	OutputShortCircuit	
	223	PWM Failure	
	224	Ground Fault Detected	
250	CR Comm Fail		

	251	kWhMeterComm Fail	
	252	CCU Comm Fail	
EV Error	301	Battery overvoltage	
	302	Battery undervoltage	
	303	Battery current deviation error	
	304	High battery temperature	
	305	Battery voltage deviation error	
	306	Charger Connector Lock Fault	
	307	Vehicle shift position	
	308	Error Status Noticed by EV	
	309	PLC Low Level Comm Fail	
	310	PLC High Level Comm Fail	
	311	PLC Authentication Timeout	
312	PLC ParamDiscovery Timeout		
Canceled	401	Local Stop	
	402	Server Stop	
	403	Network fault	
	404	Reboot	
	405	DeAuthorized	
	406	One-Click Stop	
	407	Hard Reset	
	408	Soft Reset	
Other	501	Other	
PCU	2000	PCU refuse invalid cmd	
	2001	PCU refuse request voltage too high	
	2002	refuse request current too high	
	2003	has non-usable PM	
	2004	has no power distribute	
	2005	port fault	
	2006	PCU receive gun ID abnormal	
	2051-2109	PCU currently has an alarm	

Appendix 5) Torque Table

Screw specification (applicable scenario)	Normal torque (kgf.cm)	Normal torque (in-lbs)	Primary tightening tool	Secondary tightening tool
M4 (connection between DC contactor and copper bar)	12±10%	10.4±10%	Electric screwdriver	torque screwdriver
M5 (connection between air switch/lightning arrester and cable)	18--20	15.6±10%	Electric screwdriver	torque screwdriver
M5 (connection between copper bars and between cable and terminal)	30±10%	26±10%	Electric screwdriver	Cross screwdriver or torque screwdriver
M6 (connection between copper bars and between cable terminals)	45±10%	39.1±10%	Electric screwdriver	Cross screwdriver, torque screwdriver or wrench
M6 (connection between AC contactor and cable)	45±10%	39.1±10%	Electric screwdriver	Slot-type screwdriver and torque screwdriver
M6 (connection between DC contactor and copper bar)	45±10%	39.1±10%	Electric screwdriver	Torque screwdriver or wrench
M8 (connection between copper bars and between shunt and copper bar)	110±10%	95.4±10%	Electric screwdriver	Wrench, rocker arm or torque wrench
M8 (connection between DC contactor and copper bar)	100±10%	86.7±10%	Electric screwdriver	Wrench, rocker arm or torque wrench
M10 (connection between copper bars and between shunt and copper bar)	220±10%	191±10%	Electric screwdriver	Wrench, rocker arm or torque wrench
M12 (connection between copper bars)	390±10%	338.5±10%	Electric screwdriver	Wrench, rocker arm or torque

				wrench
Screw specification (applicable scenario)	Normal torque (kgf.cm)	Normal torque (in-lbs)	Primary tightening tool	Secondary tightening tool
M4 (connection between DC contactor and copper bar)	12±10%	10.4±10%	Electric screwdriver	torque screwdriver