



ICE-60 DCWB (AC-DC) Installation and Operation Manual



Version: 2

Last Edited: 04/06/2026

InCharge Energy Inc.

All Rights Reserved. This Manual May Be Subject to Change Without Notice

Failure to follow the installation and operations manual may void the EVSE warranty.

<https://inchargeus.com/>

Service Hotline: 818-697-GOEV

Contents

1.) IMPORTANT SAFETY INSTRUCTIONS.....	4
1.1) Electrical Safety	4
1.2) Tools	5
1.3) Thunderstorm	5
1.4) Static Electricity.....	5
1.5) Short Circuit	5
1.6) Sharp Corners of Objects	6
1.7) Power Cable	6
1.8) Signal Cables	6
2.) General Product Description.....	7
2.1) Main Features	7
3.) General Characteristics	8
3.1) Technical Characteristics	8
3.2) Model Description	9
3.3) Standards	9
4.) Installation	10
4.1) Safety and Compliance	10
4.2) Grounding Instructions	10
4.3) Unboxing and Visual Inspection	10
4.4) Assembly/Placing Instructions.....	10
4.4.1) ICE-60 DCWB Wall Mounting.....	11
4.4.2) Power Cable Connections	15
5.) Start Up	16
5.1) Verification and Inspection	16
5.2) Switch On	16
6.) User Manual.....	18
6.1) Output Connector	18
6.1.1) CCS1 Connector	18

6.2) Operation Instructions	18
6.2.1) Setting the Discharge Cutoff Conditions	18
6.3) Ethernet and OCPP Setting	19
6.3.1) Connection Check	20
6.4) Network Setting	21
6.4.1) Router Set Up	21
6.4.2) Wireless Network Configuration	25
6.4.3) Wired Network Configuration	26
6.5) Charger Software Update	27
6.5.1) Upper Controller Update	27
6.5.2) Pilot Controller Update	29
Appendix 1) Engineering and Technical Parameters	30
Appendix 2) ICE-60 DCWB Schematic Diagram	31
Appendix 4) Maintenance	32
1.) Hardware Torque Values	32
2.) Maintenance Operation (ICE-60 DCWB)	33
2.1) AC Input RCD For Auxiliary Power	33
2.2) Devices and Connection Points	34
2.3) AC SPD	34
2.4) Charging Plug	35
2.5) Cooling Fan and Filter Cotton	35
2.6) ESD	37
2.7) Power Module Replacement	37
2.8) Alarm Information	38
Appendix 3) Error Codes and Possible Solutions	39

1.) IMPORTANT SAFETY INSTRUCTIONS

- Read the operating instructions and notes carefully before starting operation to prevent accidents. The "Caution, Attention, Warning, and Danger" statements in the products and product manual do not represent all safety matters to be observed and are intended to supplement various operational safety precautions.
- During the various operations of our products and equipment, it is necessary to comply with the relevant National Safety Regulations and strictly observe the precautions and special safety instructions for the relevant equipment provided by InCharge Energy
- Any usage of water on the charger during a charge session or during idling is a safety hazard and prohibited.

1.1) Electrical Safety

 Danger	<p>Since some parts of this power system are under high voltage during operation, direct or indirect contact can be fatal.</p>
---	--

- It is necessary to comply with the relevant National Safety Regulations during the installation of the Portable DC Charger. Personnel who install and maintain this equipment must be qualified to work with high DC voltage up to 1000Vdc and 3-phase AC voltage up to 500Vac.
- It is strictly forbidden to wear watches, bracelets, bangles, rings and other conductive objects on the wrist during installation and maintenance.
- If there is water inside the DC Charger enclosure, AC power and DC connector must be disconnected immediately. During operation in a humid environment, water should be strictly prevented from entering the equipment.
- During installation, it is strictly forbidden to operate the DC Charger and an "Operation prohibited" signboard must be used.

 Danger	<p>Construction operation of high voltage lines may cause fire or electric shock. The wiring area and the area where the line passes through for AC cables must comply with national and local regulations and norms. As this device utilizes high voltages do not attempt to install this equipment if you are not a qualified electrician.</p>
---	--

1.2) Tools

 Warning	<p>Special tools must be used during various operations involving high DC and AC voltages.</p>
---	--

1.3) Thunderstorm

 Danger	<p>It is strictly forbidden to carry out live installation and maintenance work during thunderstorms.</p>
--	---

- A strong electromagnetic field will be produced in the atmosphere during a thunderstorm. Therefore, the equipment should be well grounded to avoid damage to the equipment due to lightning strikes.

1.4) Static Electricity

 ESD Caution	<p>Static electricity generated by the human body may damage electrostatic sensitive components on the circuit boards, such as the large-scale integrated circuit (IC), etc. Before handling any patch boards, circuit boards and IC chips, it is necessary to wear an anti-static wrist strap with the anti-static wrist strap wire connected to Ground to avoid damage to sensitive components due to static electricity.</p>
--	---

1.5) Short Circuit

 Danger	<p>During operation, it is strictly forbidden to short-circuit the positive and negative of the DC Charger DC distribution or short-circuit any DC distribution polarity to Ground. The DC Charger is a high voltage DC power supply, and short circuit may cause damage to the DC Charger and personal safety hazards.</p>
--	---

- During work with High Voltage DC output, it is necessary to strictly check the polarity of cables and interface terminals.
- The space for DC power distribution work is compact and attention should be paid to planning cable routing etc. before starting any installation work.
- Insulated tools must be used.
- During live work, attention should be paid to keeping hands, arms tools etc. away from live high voltage parts to avoid accidents.

1.6) Sharp Corners of Objects

 Warning	During the handling of equipment by hand, it is necessary to wear protective gloves to prevent injuries caused by sharp objects.
---	--

1.7) Power Cable

 Caution	Make sure that the cable label is correct before the connection of cables.
---	--

1.8) Signal Cables

 Caution	Signal cables should be kept away from power cables, with a minimum distance of 100mm.
---	--

2.) General Product Description

2.1) Main Features

- The ICE-60 DCWB can fast charge all electric vehicles compliant with combined charging system (CCS1) charging system standards.
- IP55 for severe environment using -30°C to 50°C ambient temperature full power charging.
- Depending on the battery capacity, ICE 60 K3 can charge properly equipped electric vehicles from 0% to 80% in roughly 60 minutes, output power from 30 kW to 60 kW output voltage from 150V to 1000V.
- The battery charging state is displayed on the HMI and the charging cycle finishes by itself or can be interrupted by user command.
- The ICE-60 DCWB is user-friendly and safe. After user identification, it only requires coupling the charger's output plug in the EV for automatic starting if all safety features are accomplished.
- Full safety function with output contactor and fuse, ESD, SPD leakage switch insulation detector software logic for multiple protection.
- LTE wireless modem support, RFID authorization and Mobile App payment support

3.) General Characteristics

3.1) Technical Characteristics

- ICE-60 DCWB technical characteristics are indicated in Table 1.
- This system is intended to have at least one DC output connection (CCS1 / NACS).

Table 3-1: ICE-60 DCWB Technical Characteristics

Technical Data		Description	Remarks
Nominal Input	Phases/Lines	3 phases + PE	
	Voltage	480/277 Vac (+/-10%)	
	Frequency	60Hz	
	Current	Max 77A	
	Power	60kW	
	Power factor	≥0.99	
	System Efficiency	≥ 95% (Full load)	
DC Output CCS1	Voltage	150~1000Vdc	
	Current	200A	
	Nominal Power	60kW	
Cabinet	Dimensions(W*D*H)	27.8*9.4*43.3 in (705*240*1100 mm)	
	Weight	154.32lbs (70 kg) (excluding power modules, each power module is 34.17lbs (15.5kg .))	
	Protection Degree	NEMA 3S (IP55), IK10	
HMI and Command Unit	Local interface	TFT Color touch display 7"	
	Communication	Router 3G/4G (GSM, CDMA or LTE)	
	Protocol	OCP1.6	
Environmental conditions	Operating temperature ¹	-22°F to 122°F (-30°C~+50°C)	
	Transportation/storage temperature	-40°F to 158°F (-40°C~+70°C)	
	humidity	5%RH~95%RH	
	Place of installation	Indoor / Outdoor ²	
	Altitude	6561.68ft (2000m)	
	Sound Noise	≤70dB (nominal input/output power, the environment temperature is 25°C.)	
	Atmospheric pressure	80KPa~110KPa	
	Overtoltage category	III	
Protection class	Class I		
Note 1: The DC Charger provides full output power up to 122°F (50°C), output power derating 5% / °C above 122°F (50°C).			
Note 2: The protection level of the DC Charger is IP55. But for charging safety it should not be used during rain or snow if water can reach the charger connector.			

3.2) Model Description

Table 3-2: Model Overview

Model	Configuration	Output Power
ICE-60 DCWB		
I60W-C1C1-R	CCS1 + CCS1	60 kW

3.3) Standards

The System complies with the following standards:

Table 3-3: Applicable Standards

Technical Data	UL	Remarks
Applicable Standards	UL 2202:2022 R2.18 UL 2231-2 R08.16 UL 2231-1 R08.16 C22.2 No. 107.1-16	

- UL2202: 2022: DC Charging Equipment for Electric Vehicles
- UL2231-2: STANDARD FOR SAFETY Personnel Protection Systems for Electric Vehicle (EV) Supply Circuits: General Requirements
- UL2231-1: STANDARD FOR SAFETY Personnel Protection Systems for Electric Vehicle (EV) Supply Circuits: Requirements for Protection Devices for Use in Charging System.
- CSA22.2: Standards that is apart the Canadian Electrical Code and ensure the safety, reliability, and performance of various electrical products.

4.) Installation

4.1) Safety and Compliance

The working voltage and current inside the charging system is very high. The following rules should always be observed to ensure personal safety:

- Only personnel who have received training for and fully mastered the knowledge of the charging system can complete installation. During installation, always observe the safety precautions mentioned in this document and all relevant National Safety Regulations.
- It is necessary to make sure that the charging system DC output is disconnected in case of operation inside the charging system. The main inputs of the charging system must also be disconnected.

4.2) Grounding Instructions

An equipment grounding conductor as well as a permanent grounding electrode is required for the ICE-60 DCWB charger connection. This runs with circuit conductors and connects to the equipment grounding bar or lead on the ICE-60 DCWB charger.

4.3) Unboxing and Visual Inspection

- Check if the exterior packaging has been damaged by mechanical impacts or any accidents during transportation.
- If applicable, check that the exterior panels of the ICE-60 DCWB are without fault.
- Check if the interior of the Quick Charger Station is clean.
- Check if the door of the Quick Charger Station is working properly.
- Check for a proper Quick Charger Station protective ground connection point, which should be interconnected with the low voltage switchboard ground connection during the installation.

4.4) Assembly/Placing Instructions

- The wall mounted charging pile comprises a body, a back plate and two-connector holders, and the body is fixed on the wall through the back plate.
- The figure below shows some details of the power cabinet drilling layout.

4.4.1) ICE-60 DCWB Wall Mounting

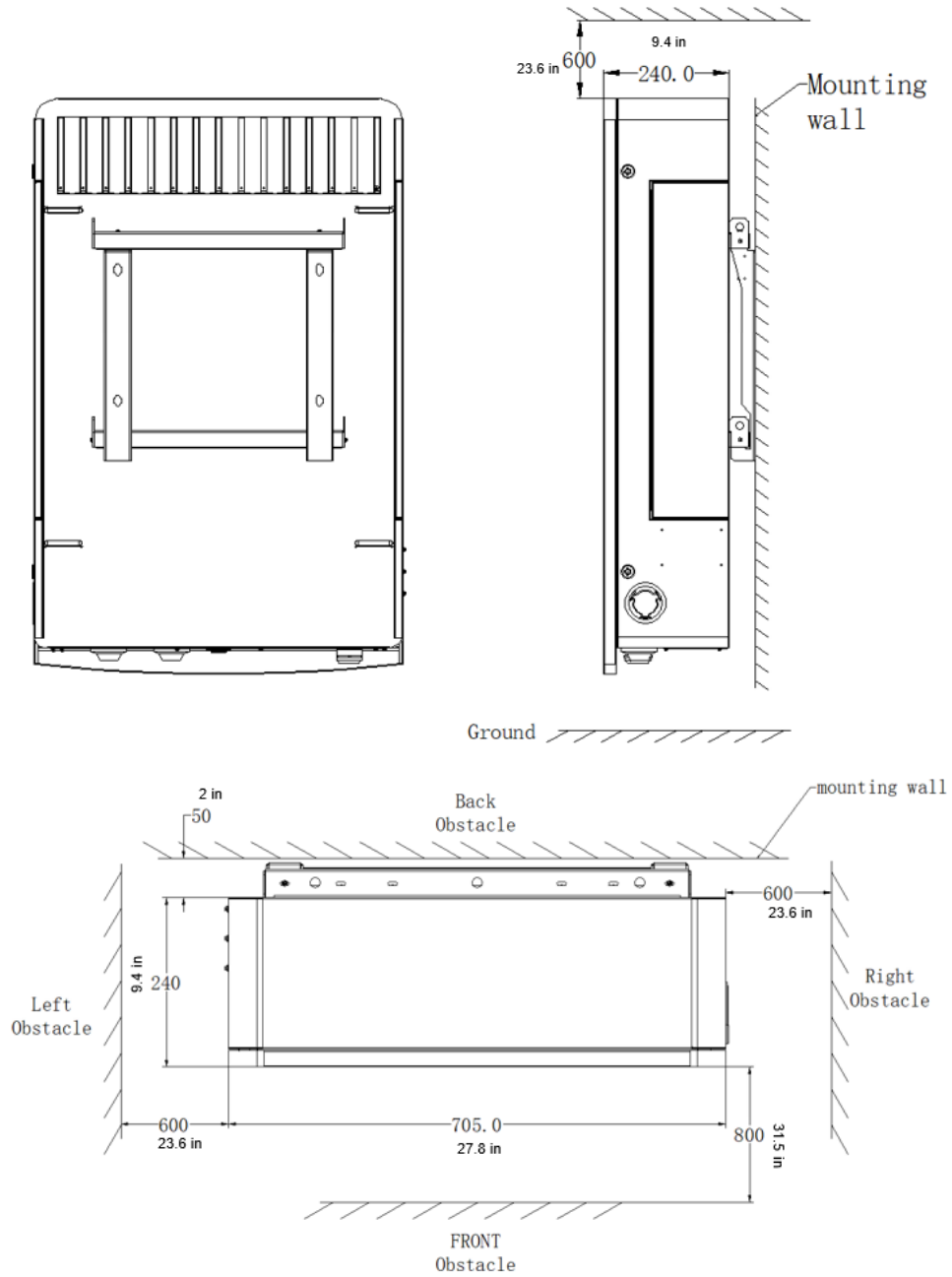

Figure 4-1: ICE-60 DCWB Space Requirements View

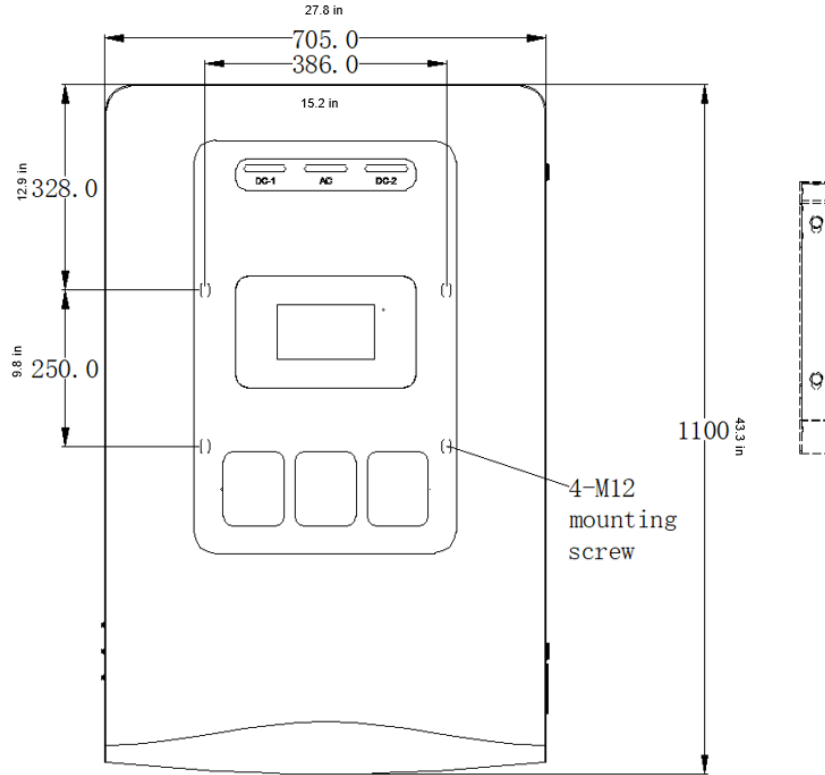

Figure 4-2: ICE-60 DCWB Back Hole Dimensions

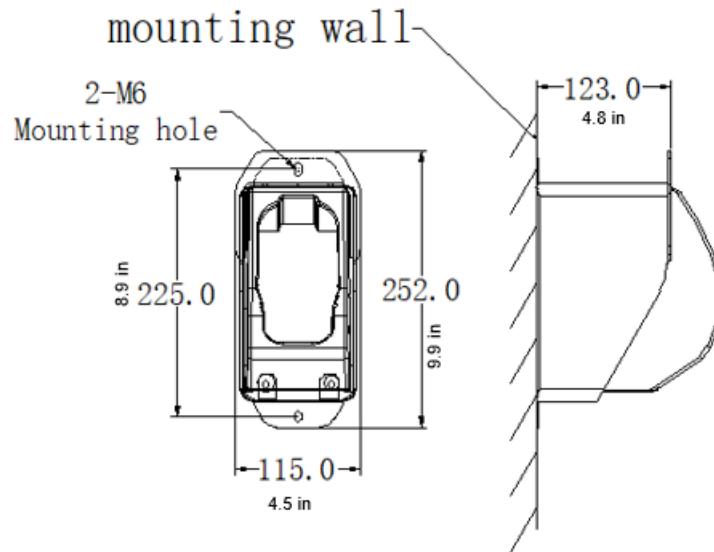
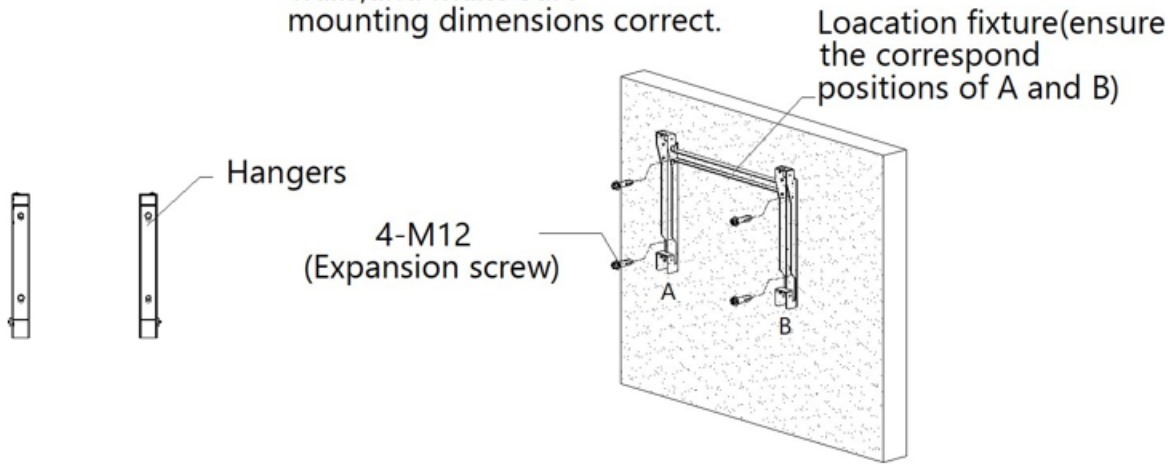
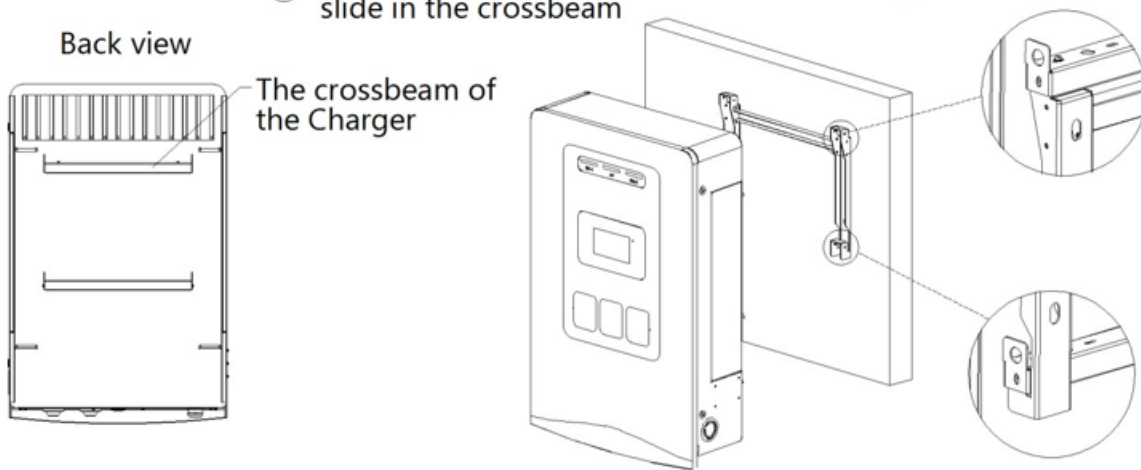

Figure 4-3: Holster Wall Mount Dimensions

- ① Fixed the hangers on the walls, and make sure mounting dimensions correct.



- ② Lift the EV Charger, and make sure the hangers slide in the crossbeam



- ③ Tighten the fastening screws for hangers and crossbeam

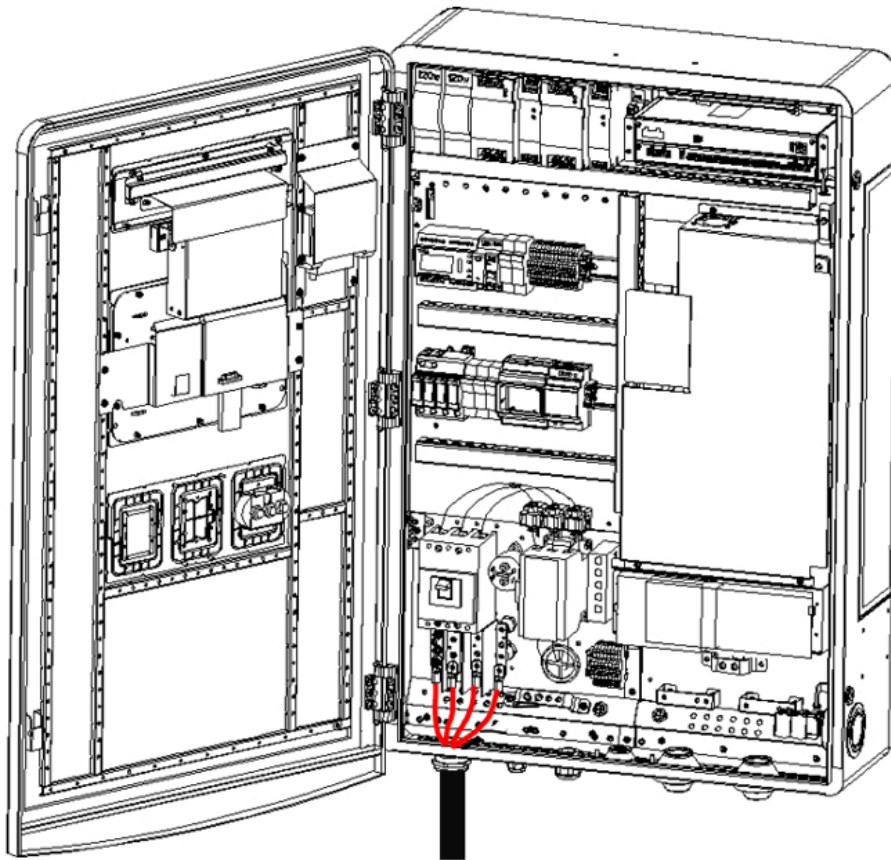
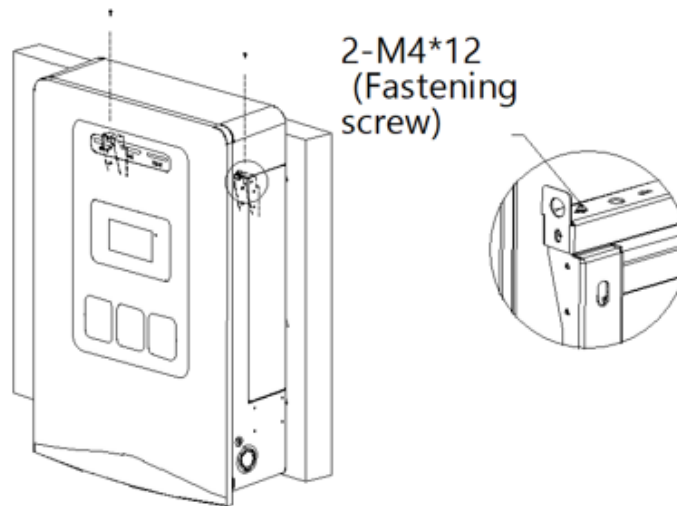

Figure 4-4: Grid Input Wiring

4.4.2) Power Cable Connections

End terminal for input wiring: 5(five) end terminals up to 3phases+neutral+protective ground

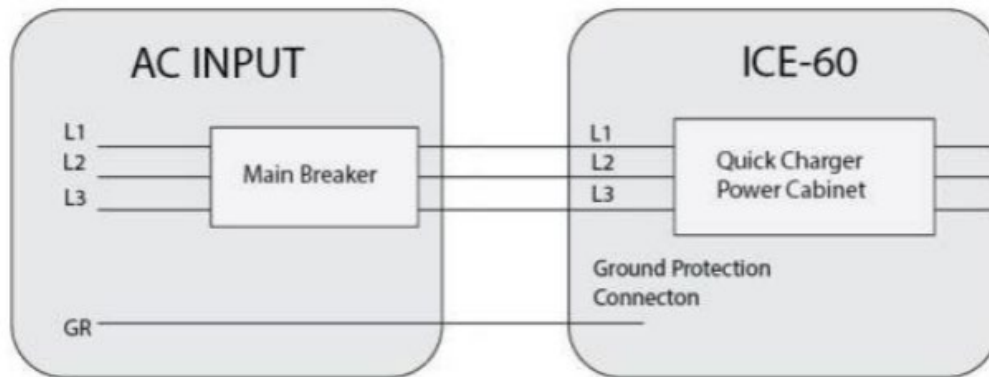

Table 4-1: AC Cables choice for ICE-60 DCWB

NO.	The section for AC feed cables	Amperage at 480Vac	Max. Power of charger	Specification of terminal screw	Tightening torque
1	1 AWG	77A	60KW	L1/L2/L3 is M6 PE is M8	M6: 39.6 lb-in M8: 97.2 lb-in

Notes:

- The AC feed power cables to the charger are not included.
- The AC feed power cables should at least be 194 F (90°C) resistant.
- The protective MCCB must be installed on the distribution cabinet, and the upper MCCB capacity should be at most 1.25 times the input current.
- It is recommended that the upper MCCB should not be equipped with RCD function.
- This system is to be connected to a grounded metal permanent wiring system; or an equipment-grounding conductor is to be run with circuit conductors and connected to equipment-grounding terminal or lead on battery charger.
- The section for feed cables is 25 to 70mm². However, within this range, the selected section is based on the distance between distribution board and charger (to be decided by customer's electrician for installation).
- A disconnecting switch must be installed on the customer's distribution board.

5.) Start Up

5.1) Verification and Inspection

- The installation location of charging device shall not be less than 20 feet away from commercial garage (repair facility) or outdoor vehicle fuel distribution device
- Check if the bolts of the AC and protective ground cables of the ICE-60 DCWB are correctly tightened to the specified torque
- Check the resistance between the ICE-60 DCWB protective ground and the low voltage switchboard ground connection; the value must be according to local codes.
- Grid AC with L1/L2/L3/PE wiring.
- Power module address setting (dip switches) is correct.
- Before switching ON all the fuses and circuit breakers, check the supply voltage between lines: it must be $480V \pm 10\%$ 60Hz.

5.2) Switch On

- Switch on all the circuit breakers in the ICE60 charger.

CCS1+CCS1 Units:

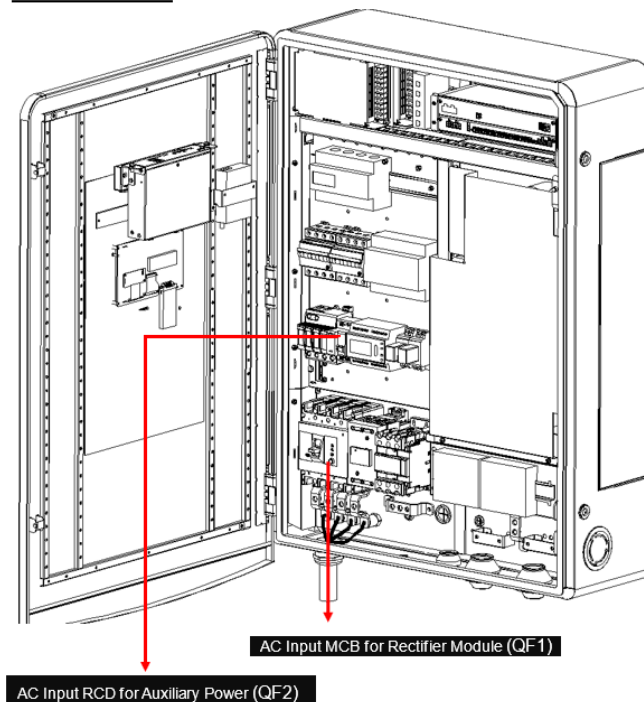

- Wait for a few seconds. The display will present a picture as below:



- Finally, the display will present the following screen.
- **CCS1 + CCS1 Units:**

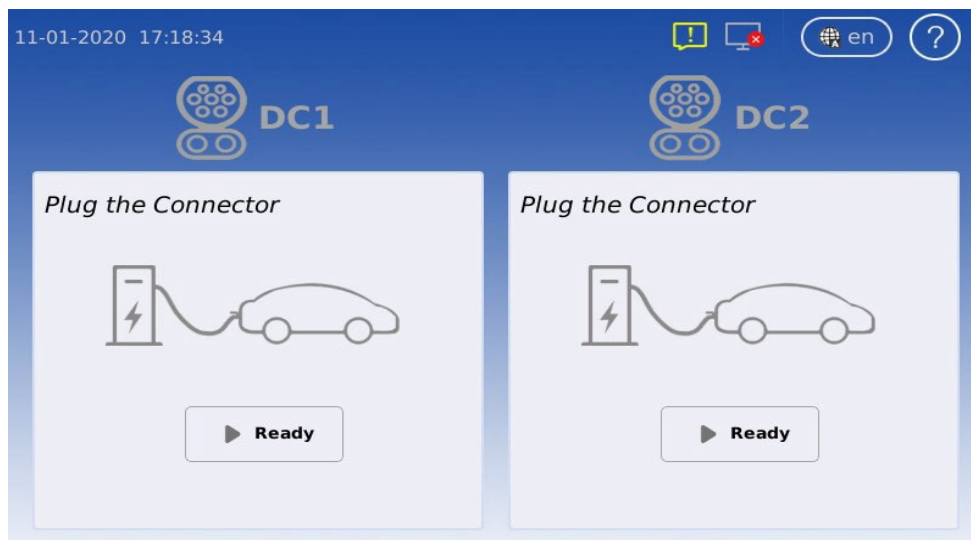

Before attempting to install or start up the charger must ensure that the safety instructions in this manual have been carefully read and observed by technically competent personnel. Keep this manual with the charger for future reference.

This charger must not be started or put into use without having been commissioned by a fully trained and authorized person.

6.) User Manual

The ICE60 operation depends on its output connection: CCS1. During the charging process, the Human Machine Interface (HMI), will give instructions and will signal different stages. These sequences are shown in this portion of the manual.

6.1) Output Connector

The ICE60 is prepared to charge electric vehicles according to the charging systems mentioned.

6.1.1) CCS1 Connector



6.2) Operation Instructions

6.2.1) Setting the Discharge Cutoff Conditions

- When a user starts an operation on the ICE-60 DCWB, the HMI display will show one of the following screens if All output connections are idle or, the unit allows the charging of DC power simultaneously.

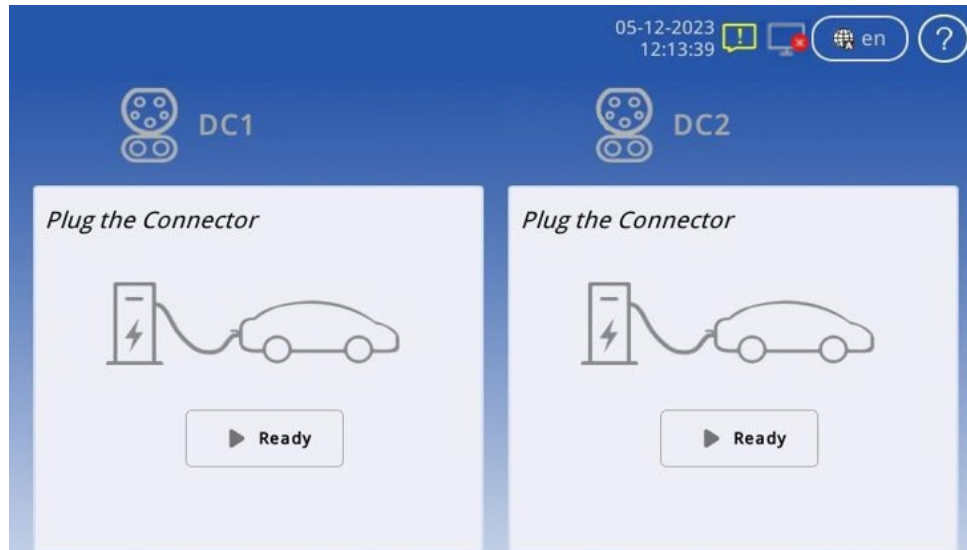

- Plug the charging gun into the vehicle interface
- Start charging on the screen
- Waiting for charging
- After the vehicle is fully charged, stop charging first, then unplug the charging gun

6.3) Ethernet and OCPP Setting

11-01-20 17:23 (Administrator)

Active Alarm Detailed Info **Param Set** Manual Ctrl Charge Rec

Charger System

Index	Parameter Name	Parameter Value
1	Time Zone	+00:00
2	System DateTime	2020-01-11 17:08:25
3	Network Setting	(Click for Detail...)
4	Charger ID	Charger123456
5	OCPP Server End URL	ws://192.168.1.200:6005
6	LCD Language	English

1/3

Here are basic descriptions of these parameters:

- **Time zone:** this determines the local time display on LCD. Adjust according to local time zone (Note this parameter only takes effect via LCD, that means even if charger is connected to OCPP server, this parameter is not affected).
- **System Date Time:** local system date time. Please set this along with time zone together.
- **Network Setting:** you can enter the sub-setting page to configure the network environment. Please refer to the next section for more details.
- **Charger ID & OCPP Server End URL:** these 2 parameters are for OCPP server communication. Please refer to the related sections below for more details.
- **LCD Language:** you can change the display language here. This has the same effect with the home page language selection dialog.
- There are 2 standard parameters for back-end setting. Please get them from the back-end supplier.
 - Charger ID
 - OCPP Server End URL

Example 1: for a charge point with identity “CP001” connecting to a Central System with OCPP-J endpoint URL "ws://centralsystem.example.com/ocpp" this would give the following connection URL:

ws://centralsystem.example.com/ocpp/CP001

Figure 7.1: Example of OCPP-J 1.6 Spec

- **Notes:** The protocol upper controller supports OCPP-J 1.6 and 2.0.1. Please refer to the OCPP official documents if you have any questions about the above 2 parameters or the protocol itself.

6.3.1) Connection Check

- If the above settings are done properly, you should see the  icon on screen (without reboot).
- Check the OCPP Platform for proper communication of the charger. Seeing the icon on the display screen only shows the charger is connected to the system but does not show the system sees the charger properly.

6.4) Network Setting

6.4.1) Router Set Up



- Look at the WIFI networks on your computer and locate the Cradlepoint Network. Connect to the Cradlepoint Wi-Fi network (Ex: IBR600C-1D7) and enter the password from the back of the device.
- Once connected to the device via WIFI, Launch a browser in either Google Chrome or Firefox, and type in 192.168.0.1

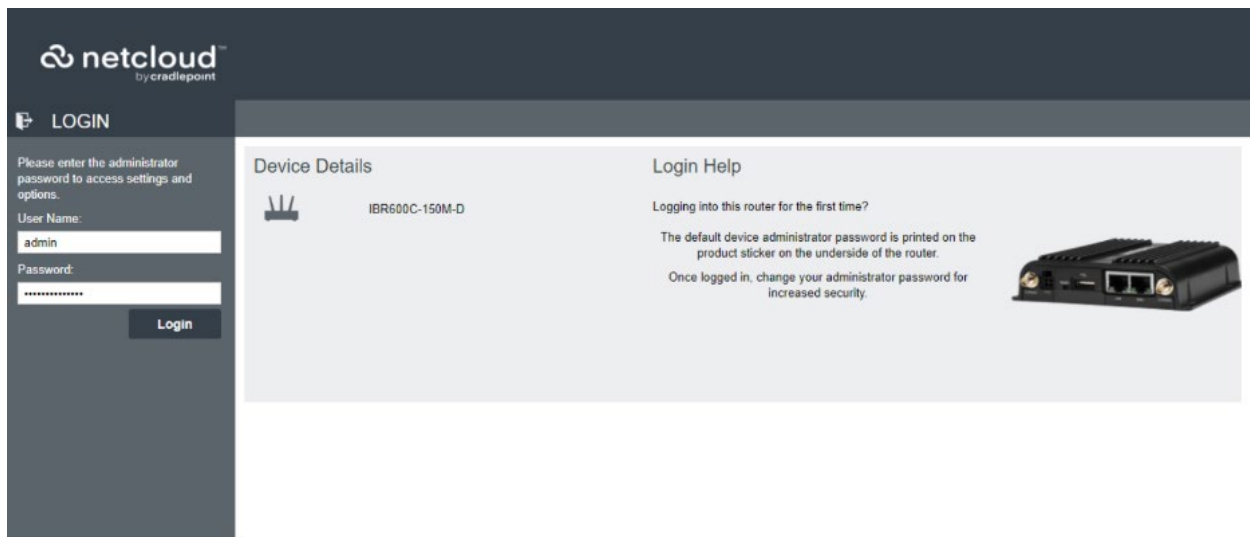

- For the Log in information, the username is (admin) and the password (Serial number from the back of the device, Ex: WA223200738571). Please note that the password is case sensitive.

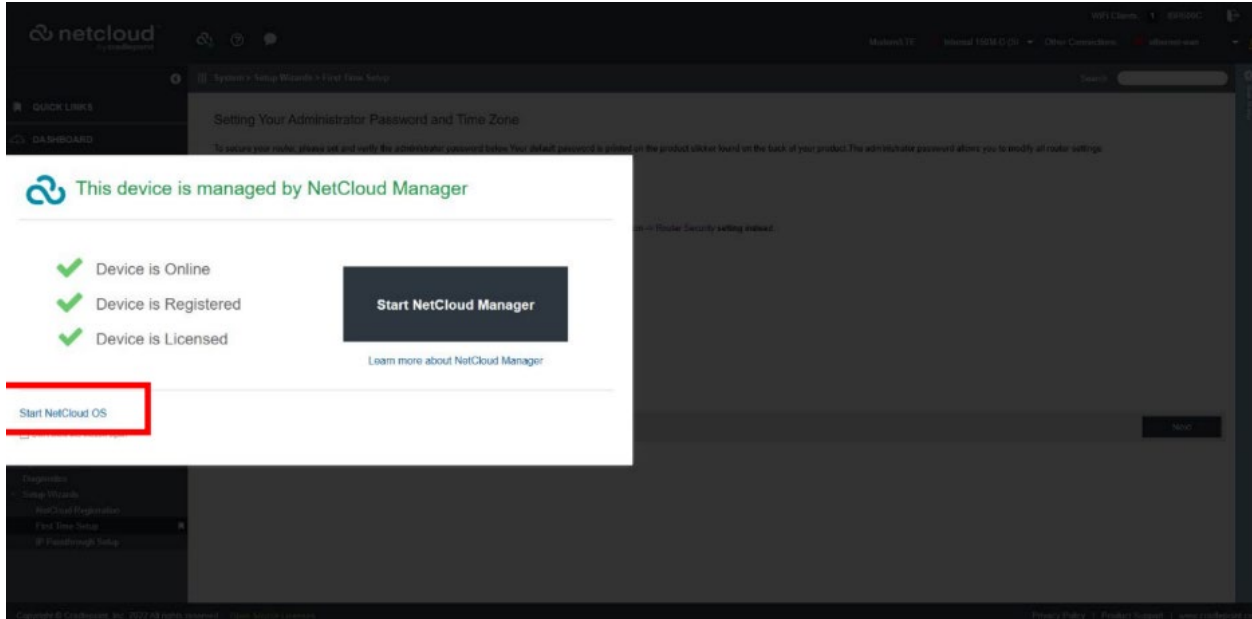

- Once logged in, click (Start NetCloud OS) and the Dashboard will launch.

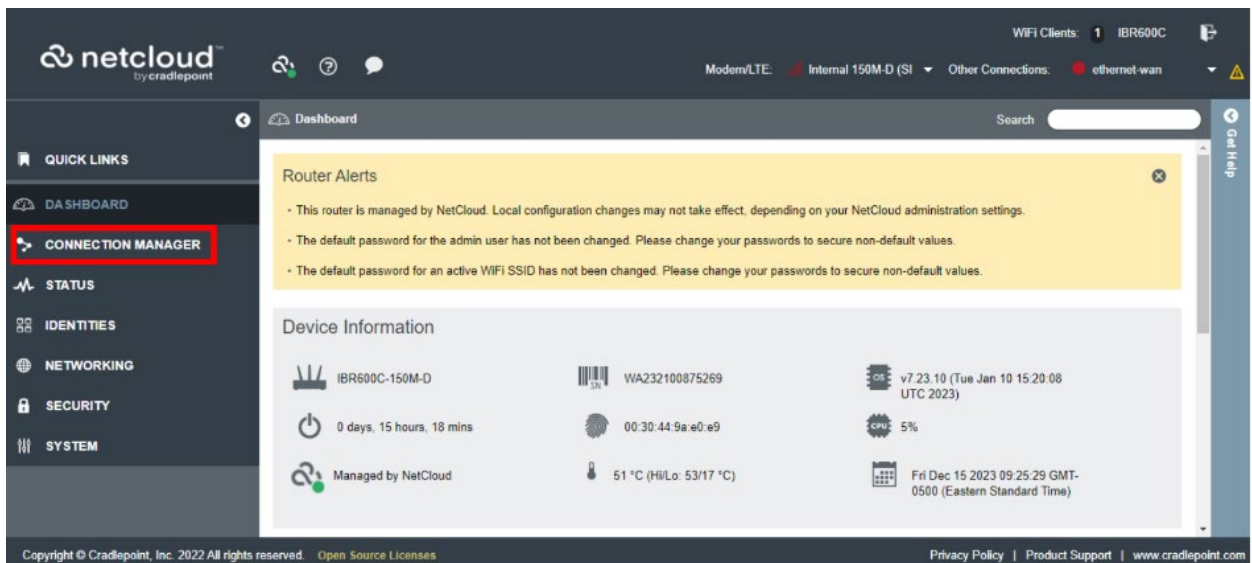

- On the left side of the dashboard, click (Connection Manager)

Connection Manager > Devices

WAN Device Interface Profiles & Priority

Profile Name	Conditions	Availability						
		✓	🔄	⏸	⏹	⏪	⏩	⏴
5G/LTE Multi-mode Modems	type is Modem + tech is 5G/LTE	☑	⚙	⚙	⚙	⚙	⚙	⚙
LTE-only Modems	type is Modem + tech is LTE	☑	⚙	⚙	⚙	⚙	⚙	⚙
LTE/3G Multi-mode Modems	type is Modem + tech is LTE/3G	☑	⚙	⚙	⚙	⚙	⚙	⚙
Internal 150M-D (SIM1 - NO SIM)	(SIM error: NOSIM)	☑	⚙	⚙	⚙	⚙	⚙	⚙
Internal 150M-D (SIM2 - AT&T)	(Connected)	☑	⚙	⚙	⚙	⚙	⚙	⚙
WiFi as WAN	type is WWAN	☑	⚙	⚙	⚙	⚙	⚙	⚙
3G-only Modems	type is Modem + tech is 3G	☑	⚙	⚙	⚙	⚙	⚙	⚙

- Click (Internal 150M-D (SIM2 – AT&T)) from the list. Please note that the error (CPMM Failed: Carrier Reject) means the APN has not yet been provided.

WAN Interface Profile

SIM Card Lock: (Modem State: No Pin)

Authentication Protocol:

Username:

Password:

Access Point Name (APN):

APN:

APN Type:

- Right click on the (Internal 150M-D (SIM2 – AT&T)) and click (Edit)
- Click (SIM/APN/AUTH)
- Set Access Point Name (APN) to “Default Override”
- In the APN field, type in (BROADBAND)

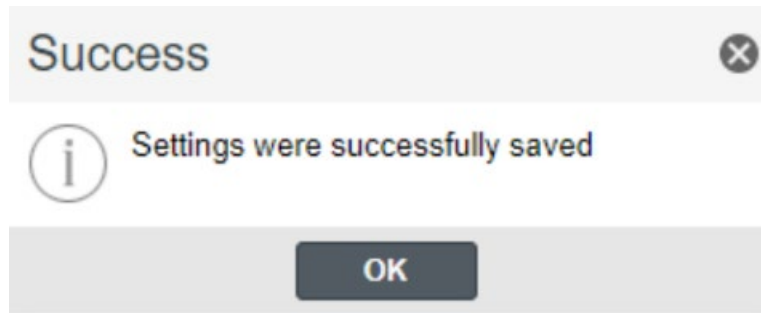

- Click Save
- The device will now be rebooted.

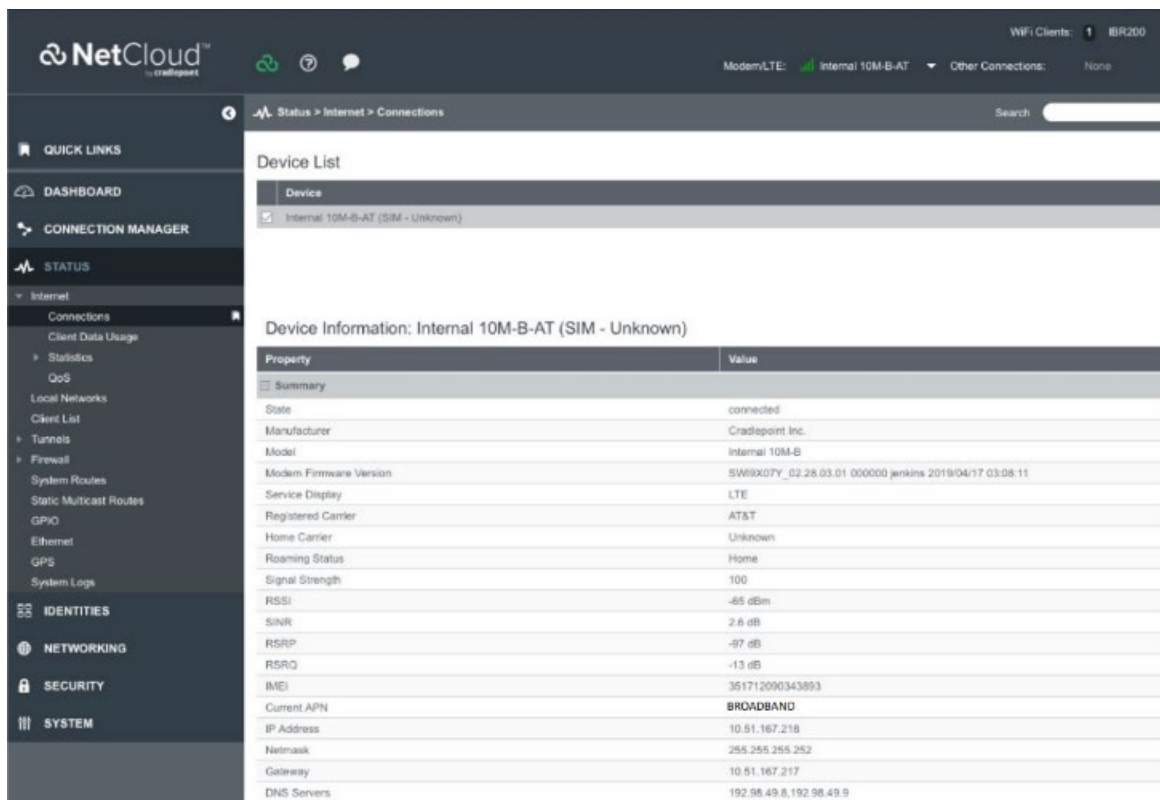

The screenshot shows the NetCloud web interface. The top navigation bar includes the NetCloud logo, a search bar, and status indicators for "WiFi Clients: 1 BR200", "Modem/LTE: Internal 10M-B-AT", and "Other Connections: None". The left sidebar contains a menu with categories like QUICK LINKS, DASHBOARD, CONNECTION MANAGER, STATUS, IDENTITIES, NETWORKING, SECURITY, and SYSTEM. The main content area is titled "Status > Internet > Connections" and displays a "Device List" with one entry: "Internal 10M-B-AT (SIM - Unknown)". Below this, a "Device Information" section for the selected device is shown as a table.

Property	Value
Summary	
State	connected
Manufacturer	Cradepoint Inc.
Model	Internal 10M-B
Modem Firmware Version	SW89X07Y_02.28.03.01.000000.jenkins.2019/04/17.03:08:11
Service Display	LTE
Registered Carrier	AT&T
Home Carrier	Unknown
Roaming Status	Home
Signal Strength	100
RSSI	-65 dBm
SINR	2.6 dB
RSRP	-97 dB
RSRQ	-13 dB
IMEI	351712090343993
Current APN	BROADBAND
IP Address	10.51.167.218
Netmask	255.255.255.252
Gateway	10.51.167.217
DNS Servers	192.96.49.8,192.96.49.9

- To check signal strength --> On the dashboard --> click Status --> Internet --> Connections --> and it will show the device information.

WAN Device Interface Profiles & Priority

+ Add ✎ Edit ✖ Delete 🔧 Control

	Profile Name	Conditions	Availability								
			✓	📄	↔	🕒	(*)	↶	📊	📉	
☰	Ethernet	type is Ethernet	☑	⚙️	⚙️	⚙️	⚙️	⚙️	🟢	⚙️	⚙️
☰	Ethernet WAN (VID: 1)	(Unplugged)	☑	⚙️	⚙️	⚙️	⚙️	⚙️	🟢	⚙️	⚙️
☰	5G/LTE Multi-mode Modems	type is Modem + tech is 5G/LTE	☑	⚙️	⚙️	⚙️	⚙️	⚙️	🟢	⚙️	⚙️
☰	LTE-only Modems	type is Modem + tech is LTE	☑	⚙️	⚙️	⚙️	⚙️	⚙️	🟢	⚙️	⚙️
☰	Modem-c7087f10	type is Modem + tech is LTE/3G + uid is c70...	☑	⚙️	⚙️	⚙️	⚙️	⚙️	🟢	⚙️	⚙️
☰	Internal 150M-D (SIM2 - AT&T)	(Connected)	☑	⚙️	⚙️	⚙️	⚙️	⚙️	🟢	⚙️	⚙️
☰	LTE/3G Multi-mode Modems	type is Modem + tech is LTE/3G	☑	⚙️	⚙️	⚙️	⚙️	⚙️	🟢	⚙️	⚙️

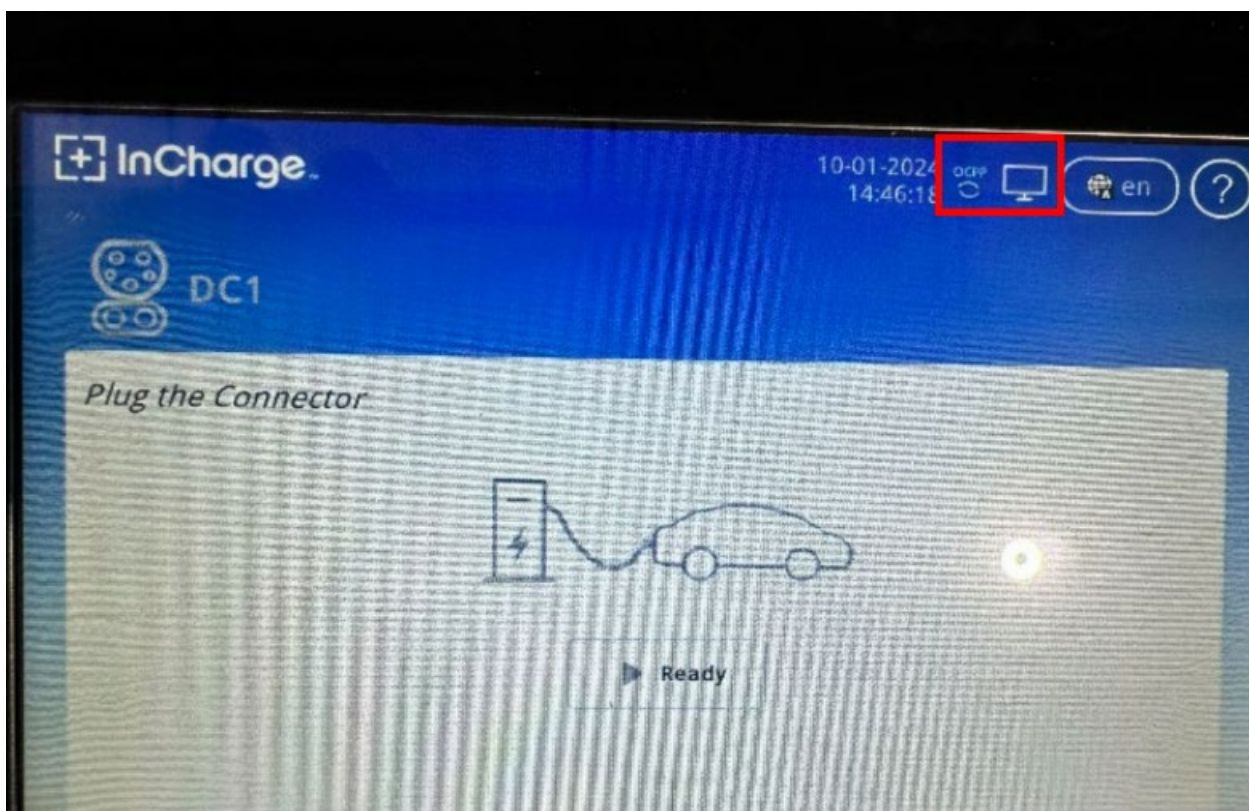

- Verify the EVSE shows these icons in the upper right corner.
- After verification, then the Device is now ready to use.

6.4.2) Wireless Network Configuration

- First, check if your system is equipped with an external wireless router.
- This router is installed inside the Power Cabinet and is interconnected with the Network Switch with a RJ45 network cable. The router is usually pre-installed along with the charger before leaving the factory, therefore the only thing needed to ensure it is operating properly.

6.4.3) Wired Network Configuration

- First, check if your system is equipped with an external wireless router.
- Connect the customer ethernet cable from their router LAN port to the WAN port of the Cradlepoint.

6.5 Charger Software Update

- The charger can update the firmware through OCPP or OEM backend remotely, or local update through USB drive to update the firmware of the upper controller and pilot controller.
- The following figure 6.2 software version is for reference only, the actual situation shall prevail.

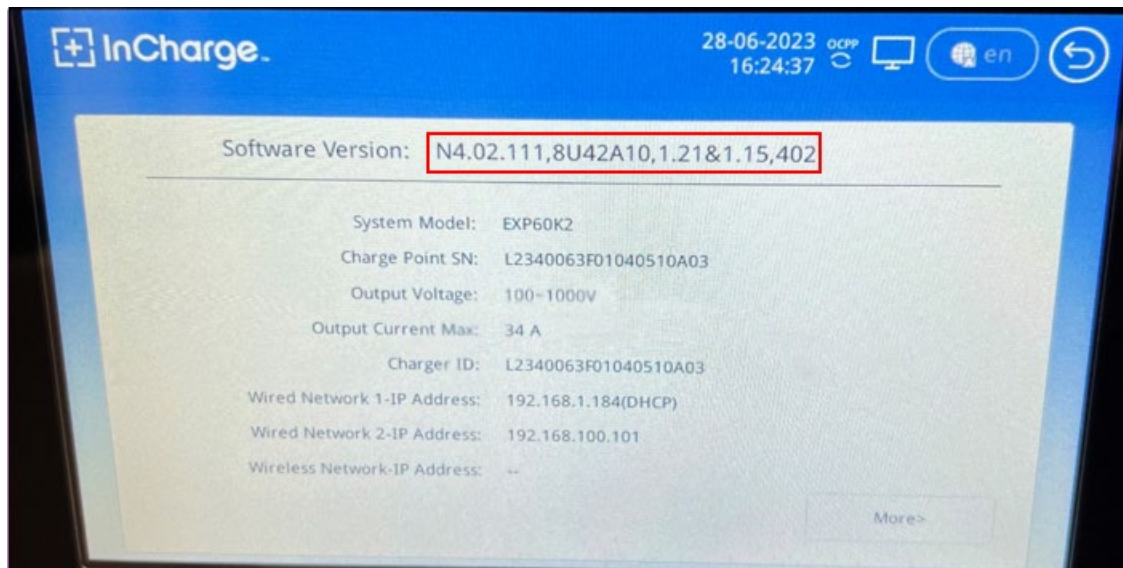

Figure 6.2: Software Version

- **CAUTION:** It is imperative that the correct firmware be installed into each component. If the incorrect firmware for a component is installed, the component may require replacement and full reprogramming prior to operating properly. Please contact InCharge Support for assistance.

6.5.1) Upper Controller Update

- For upper controller's update, firstly power on the controller, and then plug the USB drive into the controller's USB inlet and then go into the setting in "Manual Ctrl" --> "Charger System" --> "Reboot System", need to input "Soft Reset", and waiting the automatic update finish, and then take off the USB disk. Check the software version as shown in Figure 6.3.

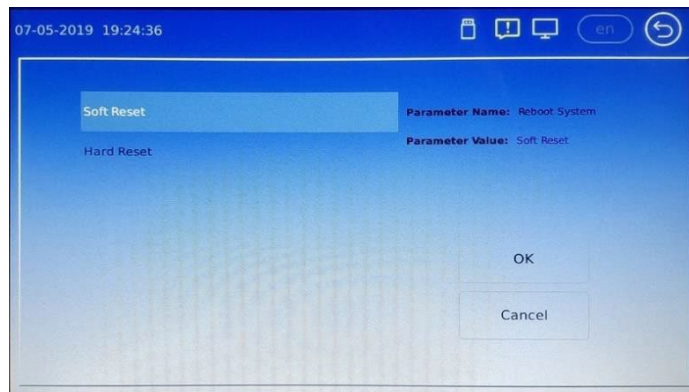
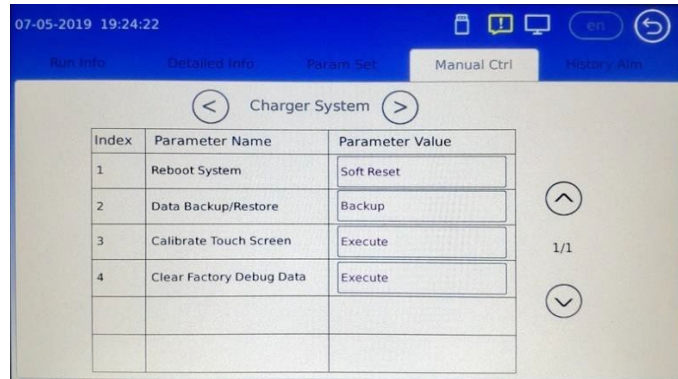

Figure 6.3: Software Version

6.5.2) Pilot Controller Update

- For pilot controller's update, firstly power on the controller, and then plug the USB disk into the controller's USB inlet. Then restart the system (disconnect the auxiliary switch, then close it again). Pay attention to the sound. After hearing three short beeps and one long beep, it means the upgrade is complete. You can pull out the USB drive. Check the software version as shown in Figure 6.3.



Figure 6.4: Pilot Controller Update Location

Appendix 1) Engineering and Technical Parameters

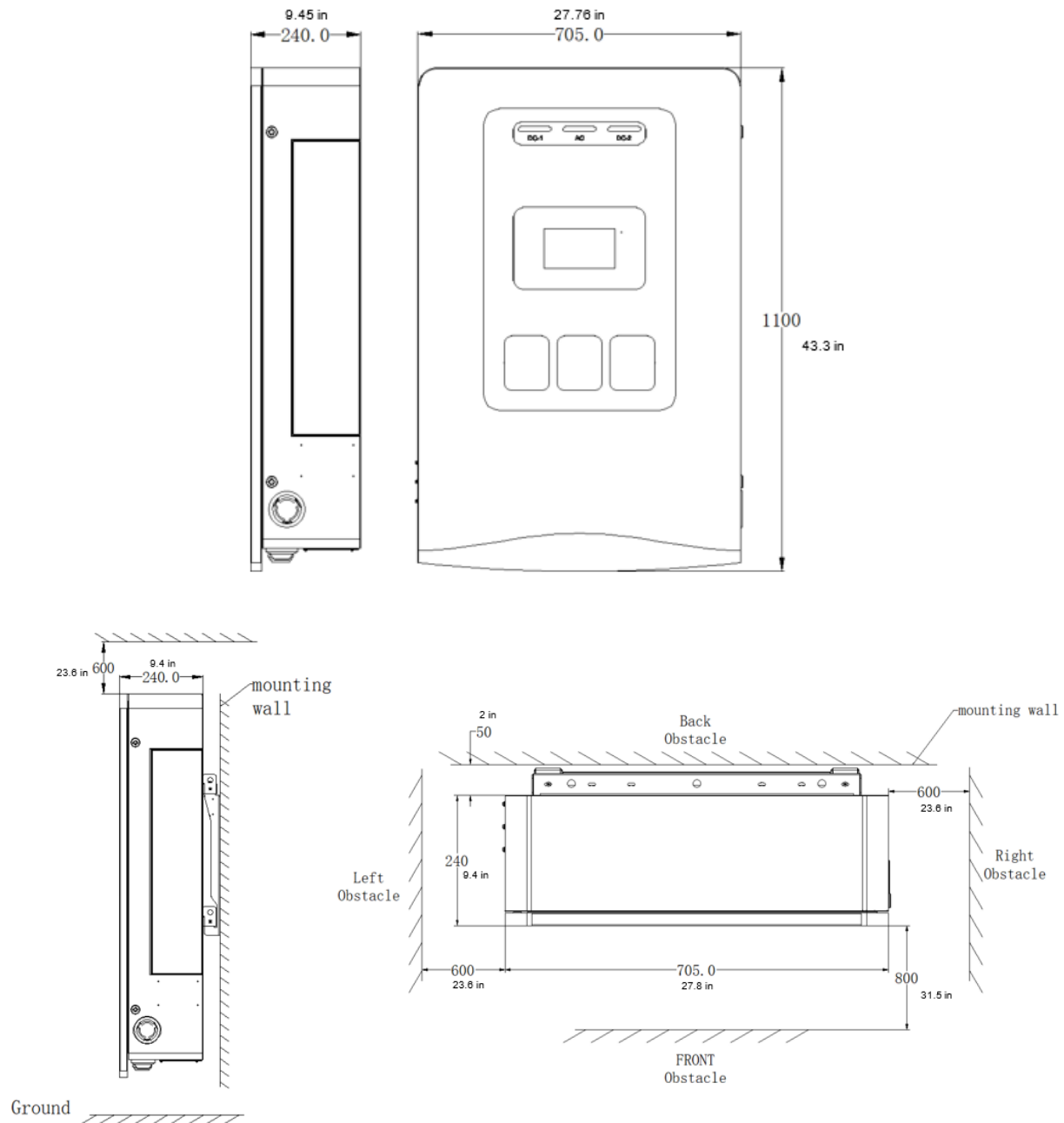

ICE-60 DCWB: Dimensional view

Appendix 2) ICE-60 DCWB Schematic Diagram

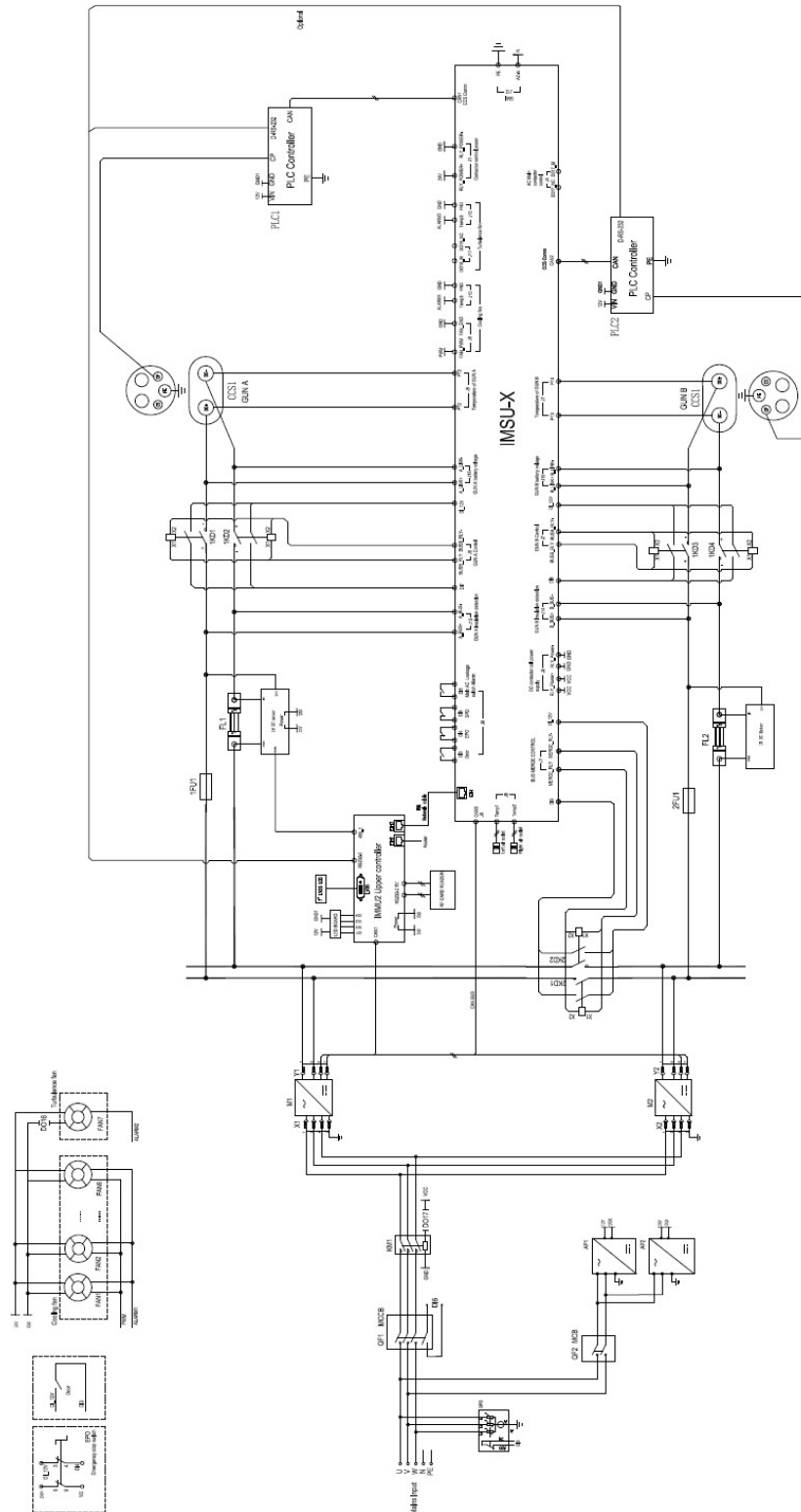

Appendix 4) Maintenance

1.) Hardware Torque Values

Hardware Torque Values

Screw specification (applicable scenario)	Normal torque (kgf.cm)	Normal torque (in-lbs)	Primary tightening tool	Secondary tightening tool
M4 (connection between DC contactor and copper bar)	12±10%	10.4±10%	Electric screwdriver	torque screwdriver
M5 (connection between air switch/lightning arrester and cable)	18--20	15.6±10%	Electric screwdriver	torque screwdriver
M5 (connection between copper bars and between cable and terminal)	30±10%	26±10%	Electric screwdriver	Cross screwdriver or torque screwdriver
M6 (connection between copper bars and between cable terminals)	45±10%	39.1±10%	Electric screwdriver	Cross screwdriver, torque screwdriver or wrench
M6 (connection between AC contactor and cable)	45±10%	39.1±10%	Electric screwdriver	Slot-type screwdriver and torque screwdriver
M6 (connection between DC contactor and copper bar)	45±10%	39.1±10%	Electric screwdriver	Torque screwdriver or wrench
M8 (connection between copper bars and between shunt and copper bar)	110±10%	95.4±10%	Electric screwdriver	Wrench, rocker arm or torque wrench
M8 (connection between DC contactor and copper bar)	100±10%	86.7±10%	Electric screwdriver	Wrench, rocker arm or torque wrench
M10 (connection between copper bars and between shunt and copper bar)	220±10%	191±10%	Electric screwdriver	Wrench, rocker arm or torque wrench
M12 (connection between copper bars)	390±10%	338.5±10%	Electric screwdriver	Wrench, rocker arm or torque wrench
Screw specification (applicable scenario)	Normal torque (kgf.cm)	Normal torque (in-lbs)	Primary tightening tool	Secondary tightening tool
M4 (connection between DC contactor and copper bar)	12±10%	10.4±10%	Electric screwdriver	torque screwdriver

2.) Maintenance Operation (ICE-60 DCWB)

#	Position	Method	Tool	Maintenance cycle
1	AC Input RCD For Auxiliary Power	Visual inspection	/	2 months
2	Devices and connection points Main circuit devices (circuit breaker, AC contactor, DC contactor, DC fuse), copper bar, power module connector	Visual inspection	Torque wrench	2 months
3	AC SPD	Visual inspection	/	3 months
4	Charging plug	Visual inspection	Brush	Daily
5	Cooling Fan and Filter cotton	Visual inspection	Blower, Screwdriver Soft Brush Vacuum Cleaner	3~6 months
6	ESD	Visual inspection	/	Daily
7	Alarm information check	Visual inspection	/	Daily

2.1) AC Input RCD For Auxiliary Power

- When the circuit breaker is in the closing state, press the trip test button to test the trip function of the circuit breaker.
- After the circuit breaker is released, the recovery method is as follows: first turn the circuit breaker to the switch on state and then turn it to the switch on state.



2.2) Devices and Connection Points

- Check the following marked areas the connection points between the main circuit components (circuit breaker, AC contactor, DC contactor, fuse) and copper bar or cable, the connection points between copper bar and copper bar, and the connector of power module for burns or serious discoloration.
- Check whether the screw fixing torque mark is normal. If there is any deviation, please re torque with a torque wrench and mark with a marker.

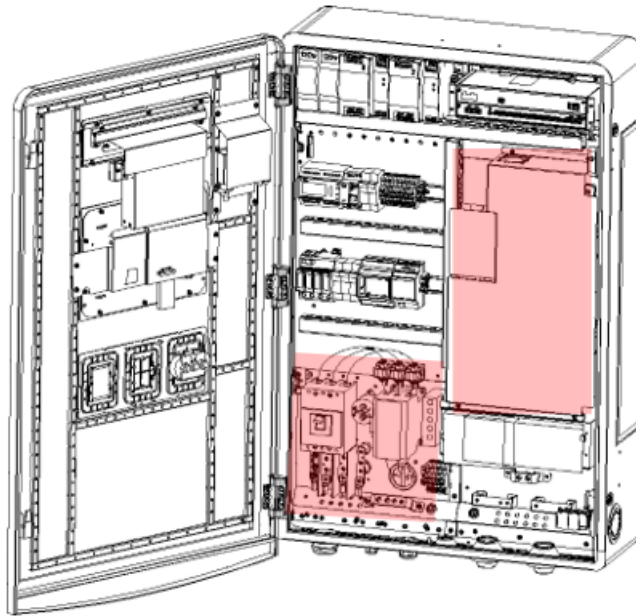

2.3) AC SPD

- Check the status window of SPD. If the window color changes from green to red, it indicates that SPD has been damaged. In this event, the manufacturer will need to be contacted for replacement.

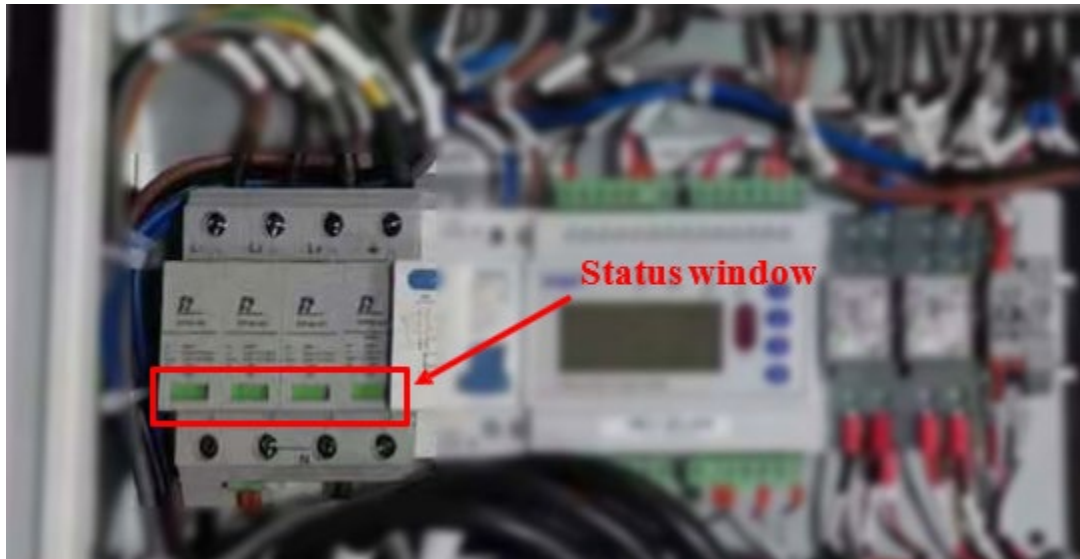

2.4) Charging Plug

- Check whether the charging plug is cracked or damaged. If so, please contact the manufacturer.
- Check whether the DC + and - terminals of the charging plug have obvious burning marks. If so, please contact the manufacturer for treatment.
- Use a brush to remove the dust on the surface of DC + and - terminals.

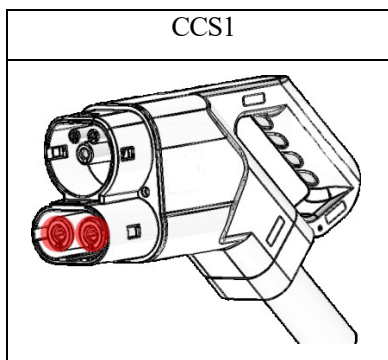

2.5) Cooling Fan and Filter Cotton

- Open the side door through the side door striker and pull out the dust screen from both sides.
- Check the dust screen on both sides for dust.
- Use the fan to clean the dust on the dustproof net.
- According to the site environment, the dust net shall be effectively removed at least once every three to six months, and it shall be replaced once a year at most.

- Remove the dust screen with a screwdriver, and use a soft brush, blower and vacuum cleaner to remove the dust effectively.
- Use vacuum cleaner and soft brush cloth to effectively remove any dust/debris in the cabinet.

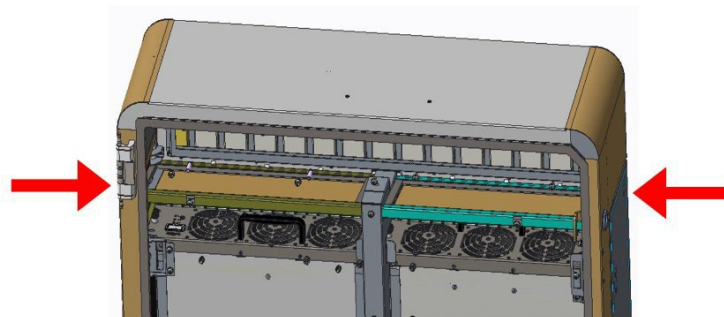
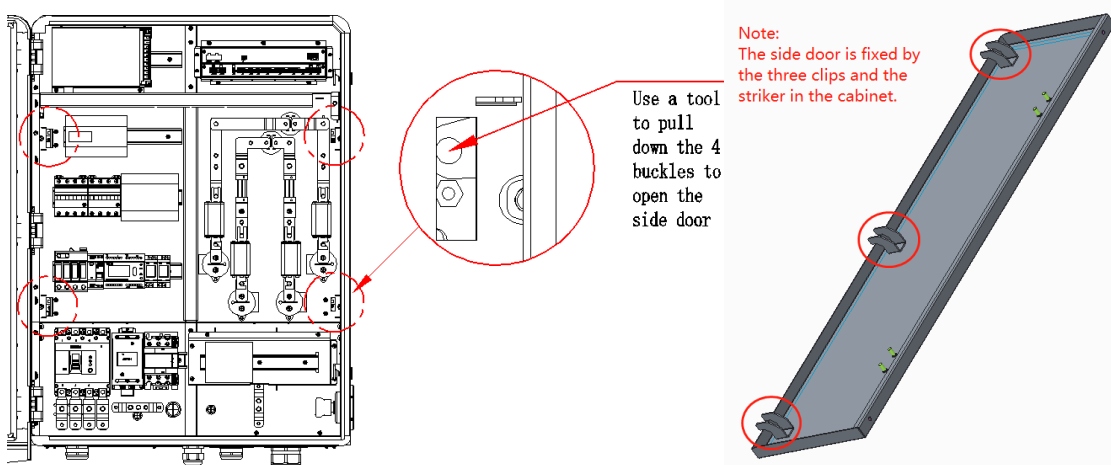

2.6) ESD

- Check the emergency stop cover plate. If the cover plate is damaged, please contact the manufacturer for replacement.

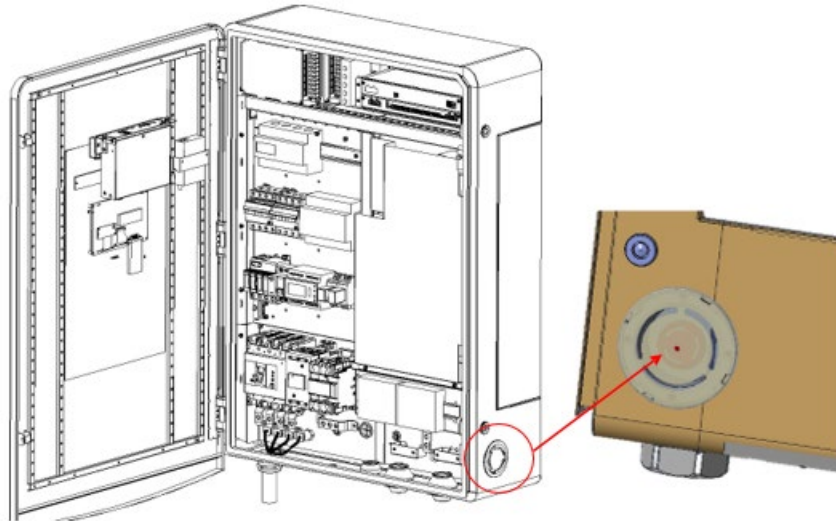

2.7) Power Module Replacement

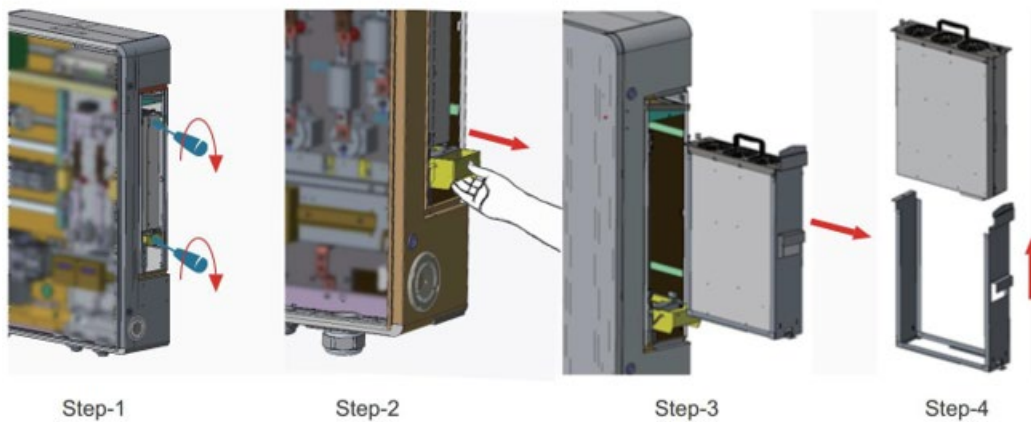

- Step-1: Use a screwdriver to loosen the screws that secure the module:
- Step-2: Pull out the yellow drawer in the direction shown in the diagram to separate the module from its socket.
- Step-3: Extract the module with the plug frame from the cabinet in the direction shown in the diagram. It is very heavy, so it's best to hold it by hand.
- Step-4: Pull the module out of the plug-in frame.
- Replace the new module. The address of the new module and the replaced module shall be consistent with the installation direction of the plug-in frame.

2.8) Alarm Information

- Click “?” In the upper right corner of the screen to view the alarm information.
- If there is alarm information, it should be handled immediately. If it cannot be handled, contact the manufacturer to handle it.

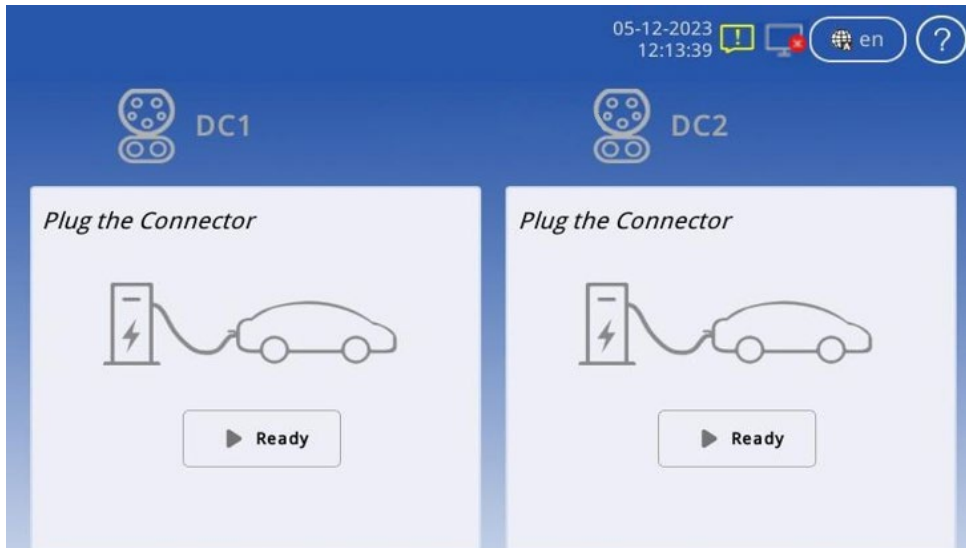

Appendix 3) Error Codes and Possible Solutions

26-03-21 15:03 (Engineer) 🔍 📺 🌐 en ↶

Active Alarm Detailed Info Param Set Manual Ctrl Charge Rec

Index	Level	Alarm Name	Source	Begin Time	Status
1	MA	Server Comm Fail	Charger System	2021/03/10 15:10:39	Started
2	CA	Communication Failed	Heat Exchange	2021/03/26 15:00:17	Started

◀ 1/1 ▶

- Reason for end of charging
- In case of abnormal shutdown, the charging interface will display the reason code for the end of charging, such as (212) in the following figure.

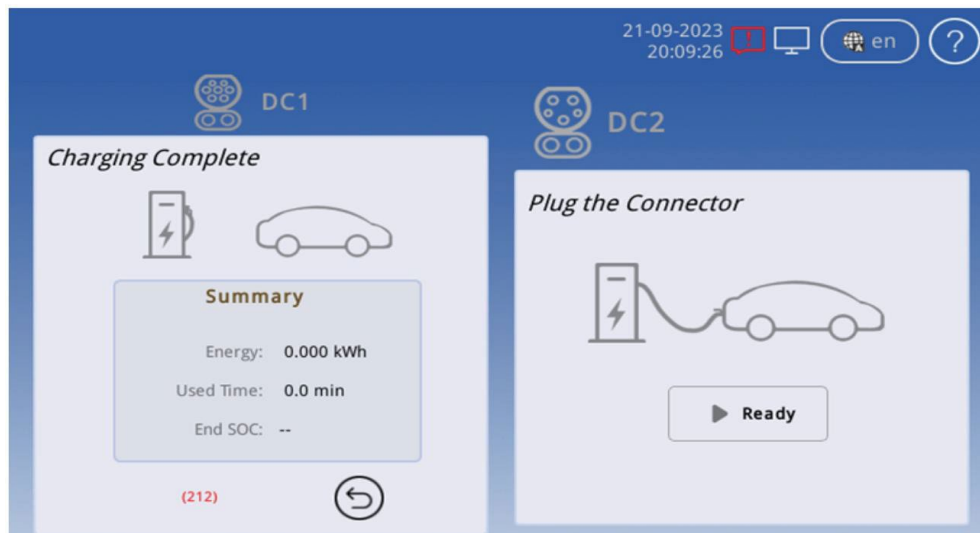

Table: Charger Alarms

NO.	Alarm ID	Alarm Name	Alarm Level	Description	Remark
1	1	System Not Available	CA	System is out of service and charge is not allowed. This usually comes after other critical alarm(e,g EPO pressed)	
2	2	System Disabled	MA	System is out of service and charge is not allowed. This happens after system is set to 'In-operative' by service guy or backend.	
3	3	All CCU Comm Fail(Not used right now)	CA	Note used any longer	
4	4	Server Comm Fail	MA	Whether the network is not accessible or the connection between server and charger is broken	
5	5	All kWhMeter Not Installed	MA	All kWh meters are set to 'Not installed'. This means system not available	
6	6	CCU Comm Fail	CA	The communication between IMM2 and IMSU-D is failed. This means system not available	
7	7	EPO is pressed	CA	This means system not available	
8	8	Door is opened	CA	This means system not available	
9	9	SPD alarm	CA	This means system not available	
10	10	Mains Fail Alarm	CA	This means system not available	
11	11	Gun is disabled	MA	The specified gun is out of service and not allowed to charge. This happens after the gun is set to 'In-operative' by service guy or backend.	Gun A/B/C shall be specified
12	12	System over temp	MA	The temperature measurement from sensor is over the high limit point (default is 75 'C)	Note that this alarm does not stop/prohibit charge function
13	13	All Rectifier Failure	CA	This means system not available	
14	14	All Rectifier Comm Fail	CA	This means system not available	
15	15	Rectifiers Failure	CA	This means the specified gun will not be available	Rectifier group 1/2 shall be specified

16	16	Rectifiers Comm Fail	CA	This means the specified gun will not be available	Rectifier group 1/2 be specified
17	17	Insulation Comm Fail	CA	This means the specified gun will not be available	
18	18	Output Shorted	CA	This is from Rectifiers after detected the internal circuit shorted	
19	19	Insulation Alarm	CA	This is from IMSU-D after detected the insulation abnormal	
20	20	PLC ComFail Alarm	CA	This is from IMSU-D when the PLC communication is lost	
21	21	Ground Fault	CA	This is from IMSU-D after detected ground fault	
22	22	AC Fail Alarm(for AC only)	CA	This is from IMSU-D after detected AC gun input fails(DI)	
23	301	CR CommFail	CA	The communication between IMMU2 and Card Reader is failed. This usually means the authentication with RFID card loses efficacy and user has to take other method instead(e.g OTP)	
24	401	kWhMeterCommFail	CA	The communication between IMMU2 and specified kWh meter is failed. This means the specified gun will be out of service and forbid to charge	
25	402	Sampled Invalid Current	CA	The measurement from the specified kWh meter is invalid. This usually happens with a reversed wiring for the current shunt.	

1. *CA* - Critical alarm *MA* - Major alarm *OA* - Observative Alarm

Stop Codes	Code	Description	Remark
Normal Stop	1	Normal Stop	Condition satisfied
	2	EV Request Stop	EV Request Stop
Charger Error	201	Parameter configuration failed	
	202	Charging Enable timeout	
	203	Abnormal volt of outside bus	
	204	Unable lock charging gun	
	205	Insulation inspection abnormally	
	206	Insulation inspection timeout	
	207	EV Relay pull-In timeout	
	208	Require Curr Timeout	
	209	Remain time over stop	
	210	Ring fail alarm (reserved)	
	211	Communication with EV failed	
	212	Plugged gun timeout	
	213	Pre Charging fault	
	214	DoorOpen	
	215	EPO	
	216	SPD	
	217	AllRectFail	
	218	MainsFailAlm	
219	AIRectCommFail		
220	E_LockFail		

	221	GunOverTemp	
	222	OutputShortCircuit	
	223	PWM Failure	
	224	Ground Fault Detected	
	250	CR Comm Fail	
	251	kWhMeterComm Fail	
	252	CCU Comm Fail	

EV Error	301	Battery overvoltage	
	302	Battery undervoltage	
	303	Battery current deviation error	
	304	High battery temperature	
	305	Battery voltage deviation error	
	306	Charger Connector Lock Fault	
	307	Vehicle shift position	
	308	Error Status Noticed by EV	
	309	PLC Low Level Comm Fail	
	310	PLC High Level Comm Fail	
	311	PLC Authentication Timeout	
	312	PLC ParamDiscovery Timeout	
Canceled	401	Local Stop	
	402	Server Stop	
	403	Network fault	
	404	Reboot	
	405	DeAuthorized	
	406	One-Click Stop	
	407	Hard Reset	
408	Soft Reset		
Other	501	Other	