

## Trademarks

Autel®, MaxiCharger®, MaxiSys®, MaxiDAS®, MaxiScan®, MaxiCheck®, and MaxiRecorder® are trademarks of Autel Intelligent Technology Corp., Ltd., registered in China, the United States and other countries. All other marks are trademarks or registered trademarks of their respective holders.

## Copyright Information

No part of this manual may be reproduced, stored in a retrieval system or transmitted, in any form or by any means, electronic, mechanical, photocopying, recording, or otherwise without the prior written permission of Autel.

## Disclaimer of Warranties and Limitation of Liabilities

All information, specifications and illustrations in this manual are based on the latest information available at the time of printing.

Autel reserves the right to make changes at any time without notice. While information of this manual has been carefully checked for accuracy, no guarantee is given for the completeness and correctness of the contents, including but not limited to the product specifications, functions, and illustrations.

Autel will not be liable for any direct, special, incidental, indirect damages or any economic consequential damages (including the loss of profits).

---

## **!** IMPORTANT

Before operating or maintaining this unit, please read this manual carefully, paying extra attention to the safety warnings and precautions.

---

### **For Services and Support (24/7):**

**Web:** [www.autelenergy.com](http://www.autelenergy.com)

**Tel:** (844) 765-0150

**Email:** [evsupport@autel.com](mailto:evsupport@autel.com)

For technical assistance in all other markets, please contact your local selling agent.

## Safety Information

---

For your own safety and the safety of others, and to prevent damage to the device and vehicles upon which it is used, it is important that the safety instructions presented throughout this manual be read and understood by all persons operating or coming into contact with the device.

(1) “IMPORTANT SAFETY INSTRUCTIONS” and “SAVE THESE INSTRUCTIONS”  
INSTRUCTIONS IMPORTANTES CONCERNANT LA SÉCURITÉ CONSERVER CES  
INSTRUCTIONS

(2) INSTRUCTIONS PERTAINING TO A RISK OF FIRE OR ELECTRIC SHOCK  
INSTRUCTIONS AYANT TRAIT À UN RISQUE D'INCENDIE OU DE CHOC ÉLECTRIQUE

## Safety Messages

---

Safety messages are provided to help prevent personal injury and equipment damage. All safety messages are introduced by a single word indicating the hazard level.

### DANGER

Indicates an imminently hazardous situation which, if not avoided, will result in death or serious injury to the operator or to bystanders.

### WARNING

Indicates a potentially hazardous situation which, if not avoided, could result in death or serious injury to the operator or to bystanders.

## Safety Instructions

---

The safety messages herein cover situations Autel is aware of. Autel cannot know, evaluate or advise you as to all of the possible hazards. You must be certain that any condition or service procedure encountered does not jeopardize your personal safety.

### SAFETY WARNINGS

- Read and follow all warnings and instructions before installing and operating the charger.
- This equipment should only be installed by a licensed electrician in accordance with all local codes and ordinances.
- This equipment must be grounded through a permanent wiring system or an equipment-grounding conductor.
- Do not install or use this equipment near flammable, explosive, harsh, or combustible materials, chemicals or vapors.

- Children should be supervised when around this equipment.
- Do not insert fingers or foreign objects into the electric vehicle connector.
- Do not use the equipment if the flexible power cord or EV cable is frayed, broken or otherwise damaged, or fails to operate.
- Do not use the equipment if the enclosure or the EV connector is frayed, broken or otherwise damaged, or fails to operate.
- Use 90 °C wire copper conductors only.
- Do not operate the equipment outside its operating temperature range of -40 to 131 °F (-40 to 55 °C).
- Incorrect installation and testing of the equipment could potentially damage the vehicle's battery, components, and/or the equipment itself.
- Handle the equipment with care during transportation. Do not subject it to strong force or impact or pull, twist, tangle, drag or step on the equipment, to prevent damage to it or any components.
- If the rules described in the manual contradict your local ordinances, refer to your local ordinances.
- Take out the SIM card tray before removing the covers for maintenance or other work.

For use with Electric Vehicles

Pour utilisation avec des véhicules électriques

Ventilation Not Required

Aucune ventilation requise

Use Copper Conductors Only

Utiliser uniquement des conducteurs en cuivre

## **CAUTION**

To avoid a risk of fire or electric shock, do not use this device with an extension cord.

## **AVERTISSEMENT**

Pour réduire le risque de choc électrique ou d'incendie, ne pas utiliser de rallonge avec cet appareil.

THE SUITABILITY OF THE USE OF FLEXIBLE CORD IN ACCORDANCE WITH CE CODE, PART I, RULE 4-012, IS TO BE DETERMINED BY THE LOCAL INSPECTION AUTHORITY HAVING JURISDICTION

C'EST À L'AUTORITÉ LOCALE COMPÉTENTE EN MATIÈRE D'INSPECTION QU'INCOMBE DE DÉTERMINER SI UN CORDON SOUPLE PEUT ÊTRE UTILISÉ CONFORMÉMENT À L'ARTICLE 4-012 DU CCÉ, PREMIÈRE PARTIE

**CAUTION**

To reduce the risk of electric shock, connect only to properly grounded outlets.

**ATTENTION**

Pour réduire le risque de choc électrique, brancher sur une prise correctement mise à la terre.

**CAUTION**

Risk of electric shock. Do not remove cover or attempt to open the enclosure. No user serviceable parts inside. Refer servicing to qualified service personnel.

**ATTENTION**

Risque de choc électrique. Ne pas retirer le couvercle ni essayer d'ouvrir le boîtier. Aucune pièce interne réparable par l'utilisateur. Confier tout travail d'entretien ou de réparation à un technicien qualifié.

**WARNING**

This device is intended only for charging vehicles not requiring ventilation during charging.

**AVERTISSEMENT**

Ce dispositif est destiné au chargement des véhicules ne nécessitant pas de ventilation au cours du chargement.

**WARNING**

Automatic reset feature is provided.

**AVERTISSEMENT**

Caractéristique de réarmement automatique incluse.

# CONTENTS

<b>SAFETY INFORMATION</b> .....	<b>II</b>
<b>SAFETY MESSAGES</b> .....	<b>II</b>
<b>SAFETY INSTRUCTIONS</b> .....	<b>II</b>
<b>1 USING THIS MANUAL</b> .....	<b>1</b>
1.1 CONVENTIONS .....	1
<b>2 GENERAL INTRODUCTION</b> .....	<b>3</b>
2.1 PRODUCT OVERVIEW .....	4
2.2 SPECIFICATIONS .....	7
<b>3 INSTALLATION</b> .....	<b>9</b>
3.1 UNPACKING .....	9
3.2 ELECTRICAL DESIGN .....	10
3.3 PREPARING FOR INSTALLATION .....	13
3.4 INSTALLING THE CHARGER .....	13
<b>4 TROUBLESHOOTING AND SERVICE</b> .....	<b>25</b>
4.1 TROUBLESHOOTING TABLE .....	25
4.2 SERVICE .....	27
<b>5 COMPLIANCE</b> .....	<b>28</b>

# 1 Using This Manual

This manual describes the installation and use of the MaxiCharger AC Wallbox Commercial. Prior to installation, read through this manual to be familiarized with the instructions of this MaxiCharger to ensure a successful installation and smooth operations.

## 1.1 Conventions

---

The following conventions are used.

### **Bold Text**

Bold text is used to highlight selectable items such as buttons and menu options.

Example:

- Tap **OK**.

### **Notes and Important Messages**

#### **Notes**

A **NOTE** provides helpful information such as additional explanations, tips, and comments.

Example:

---

#### **NOTE**

The images and illustrations depicted in this manual may differ slightly from the actual ones.

---

## **Important**

**IMPORTANT** indicates a situation which, if not avoided, may result in damage to the test equipment or vehicle.

Example:

---

### **ⓘ IMPORTANT**

The rear entry cables should be put through the cable inlet holes prior to mounting the charger to the wall dock.

---

## **Hyperlink**

Hyperlinks or links that take you to other related articles, procedures, and illustrations are available in electronic documents.

## **Illustrations**

Illustrations used in this manual are only examples; the actual product(s) or screens may vary.

# 2 General Introduction

The MaxiCharger AC Wallbox Commercial is designed to charge a plug-in hybrid electric vehicle or an electric vehicle (hereinafter called EV) for commercial use. Our chargers provide you with safe, reliable, fast, and smart charging solutions.

This manual will instruct you how to install and use this charger.

## **Intended Use**

The MaxiCharger AC Wallbox Commercial is intended for the AC charging of EVs. It is intended for both indoor and outdoor use.

---

## **DANGER**

1. If you use the equipment in any way other than described in this manual or other related documents, possible death, injury and damage to property can occur.
  2. Use the equipment only as intended.
- 

## **NOTE**

The images and illustrations depicted in this manual may differ slightly from the actual ones.

---

# 2.1 Product Overview

## MaxiCharger AC Wallbox Commercial

1. Ambient Light Sensor — detects ambient brightness
2. Display
3. LED Indicators (from left to right):
  - Power LED
  - Internet Connection LED
  - Charging LED
  - Bluetooth Connection LED
4. RFID Reader
5. Holster
6. Connector
7. AC Input Cable
8. EV Charging Cable
9. Bottom Ethernet Cable Port
10. Mounting Screws
11. Rear AC Inlet Hole
12. Rear Ethernet Cable Port

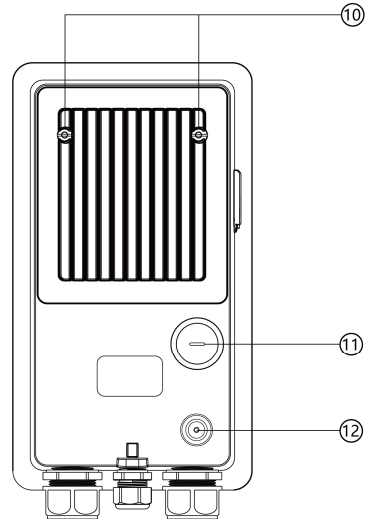
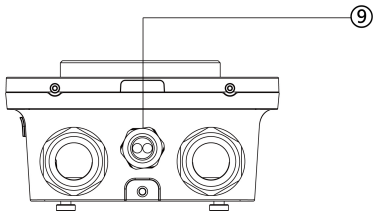
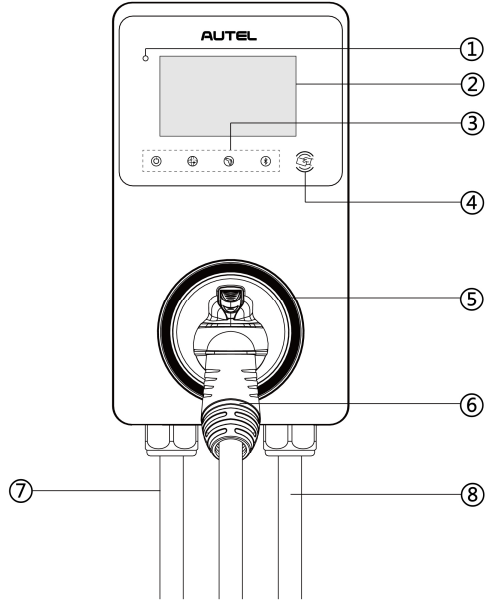

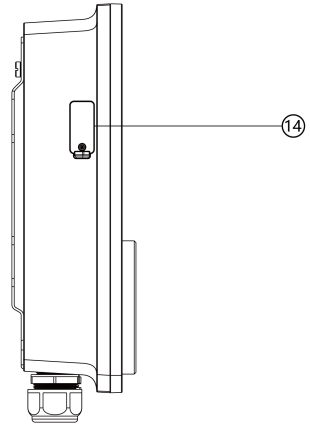
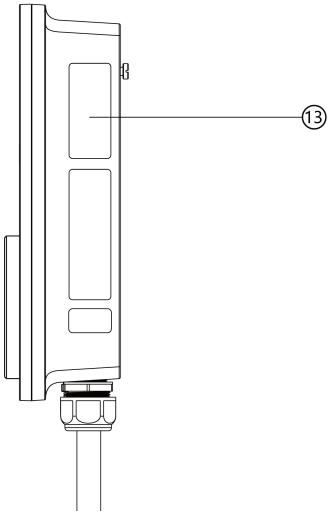

13. Product Label

14. SIM Card Socket

15. RJ45 Port

16. RS485 Port — connects the RS485 cable

17. Current Selector — adjusts the current for the charger

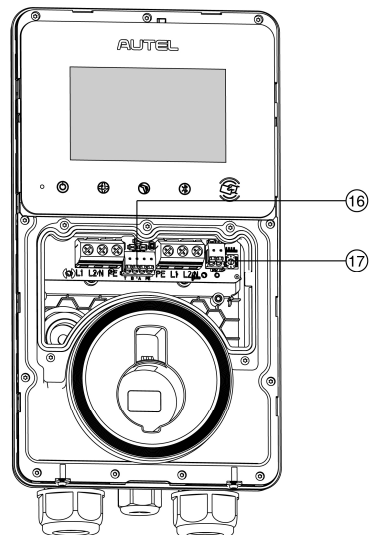
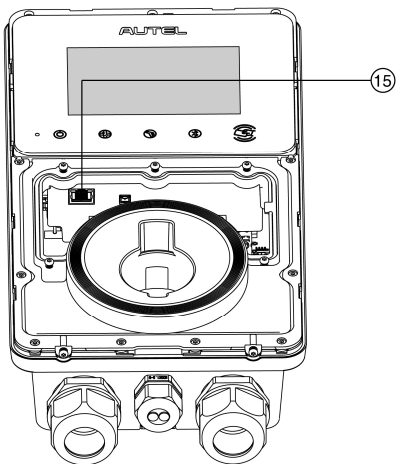

## LED Description

LED	Description
<p><b>Power LED</b></p>	<ul style="list-style-type: none"> <li>● <b>Solid Green:</b> The charger is on.</li> <li>● <b>Not Illuminated:</b> The charger is off.</li> <li>● <b>Flashing Yellow:</b> Data is being transmitted and/or firmware is upgrading.</li> <li>● <b>Solid Yellow:</b> Firmware upgrade has failed.</li> <li>● <b>Solid Blue:</b> Data transmission has failed; will illuminate green in five seconds.</li> </ul>
<p><b>Internet Connection LED</b></p>	<ul style="list-style-type: none"> <li>● <b>Solid Green:</b> The charger is connected to the Internet.</li> <li>● <b>Not Illuminated:</b> The charger is not connected to the Internet.</li> <li>● <b>Flashing Green:</b> The charger has joined the DLB (Dynamic Load Balancing) network.</li> </ul>
<p><b>Charging LED</b></p>	<ul style="list-style-type: none"> <li>● <b>Solid Blue:</b> An EV is connected.</li> <li>● <b>Flashing Blue:</b> A schedule is active.</li> <li>● <b>Flashing Green:</b> An EV is charging.</li> <li>● <b>Solid Green:</b> A charge session has ended.</li> <li>● <b>Not Illuminated:</b> The charger is not connected.</li> <li>● <b>Solid Orange:</b> A recoverable error has occurred.</li> <li>● <b>Solid Red:</b> An irrecoverable error has occurred. (Please contact support.)</li> </ul>
<p><b>Bluetooth Connection LED</b></p>	<ul style="list-style-type: none"> <li>● <b>Flashing Green:</b> The charger is connected to a mobile device via Bluetooth.</li> <li>● <b>Flashing Blue:</b> The charger is connected to the accessory VCI (Vehicle Communication Interface) via Bluetooth. (VCI sold separately.)</li> <li>● <b>Flashing Cyan:</b> The charger is connected to a mobile device and a VCI device simultaneously via Bluetooth. (VCI sold separately.)</li> <li>● <b>Not Illuminated:</b> The charger is not connected via Bluetooth.</li> </ul>

## 2.2 Specifications









Item	Description
<b>AC Power Output Rating</b>	Maximum 12 kW (240 VAC @ 50 A model)
<b>AC Power Input Rating</b>	208/240 V AC, 60 Hz, single phase @ 16 A, 24 A, 32 A, 40 A, 48 A, 50 A
<b>Circuit Breaker Options (A)</b>	20 A, 30 A, 40 A, 50 A, 60 A, 70 A
<b>Input Wiring Scheme</b>	Three wires: L1, L2, and Earth (no neutral)
<b>Input Cord</b>	Hardwired only
<b>Connector Type</b>	SAE J1772
<b>Charging Cable Length</b>	24.6 ft. (7.5 m)
<b>Display</b>	<ul style="list-style-type: none"><li>● 5-inch, 800 x 480 touchscreen</li><li>● 4 LEDs</li><li>● Ambient light sensor</li></ul>
<b>Ground Fault Detection</b>	20 mA CCID with auto retry
<b>Protection</b>	Overcurrent, overvoltage, undervoltage, integrated surge protection
<b>Connectivity</b>	<ul style="list-style-type: none"><li>● 4G</li><li>● Bluetooth</li><li>● Wi-Fi</li><li>● Ethernet</li><li>● RS485</li></ul>
<b>Card Reader</b>	ISO 15693, ISO 14443, NFC

Item	Description
<b>Sub-G (Auto Open the Tesla Charging Port)</b>	Optional
<b>Communication Protocols</b>	<ul style="list-style-type: none"> <li>● OCPP 1.6J</li> <li>● OCPP 2.0 (Optional, will be available soon)</li> </ul>
<b>Mounting</b>	Wall-mounted or floor using a pedestal
<b>Enclosure Ratings</b>	NEMA 4, indoor or outdoor installation
<b>Operating Temperature</b>	-40 to 131 °F (-40 to 55 °C)
<b>Storage Temperature</b>	-40 to 158 °F (-40 to 70 °C)
<b>Dimension (H x W x D)</b>	13" x 7" x 3" (335 x 187 x 85 mm)
<b>Weight</b>	14.8 lbs. (6.7 kg)
<b>Safety and Compliance</b>	<p>NEC Article 625 and UL 916, UL 2594, UL2231-1, UL2231-2, UL 1998, CSA C22.1 Automatic reset feature is provided.</p> <p><b>AVERTISSEMENT</b> Caractéristique de réarmement automatique incluse.</p>
<b>Codes and Standards</b>	FCC Part 15 Class B, Energy Star, OpenADR2.0 B
<b>Warranty</b>	3 years
<b>Model</b>	Maxi US AC W12-L-4G

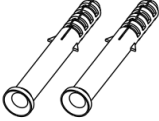

# 3 Installation

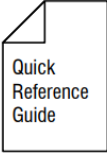
## 3.1 Unpacking

Make sure that all parts are delivered according to the order. Check the packaging for the following parts.

Charging Station		Wall Dock	
Screw (M6 x 50) 2 PCS		Screw (M5 x 12)	
Wall Anchor (5/16") 2 PCS		Bottom Entry Power Conduit Plug (M32)	
Installation Guide		Packing List	
Amperage Labels			

## Tool Kit

Screwdriver (Type T10)		Screwdriver (Type T25)	
------------------------	---	------------------------	---

---

### NOTE

The list above does not necessarily include all the tools required for installation. **We recommend you read through the installation procedure and gather all the tools needed prior to installation.**

---

## 3.2 Electrical Design

---

### 3.2.1 Upstream Wiring

Charging stations are considered continuous load devices (EVs draw maximum load for long durations); therefore, electrical branch circuits must be sized at 125% of the load for North American installations, in accordance with National Electric Code (NEC) requirements. (For other regions, refer to local code.) This means that for a maximum 50 A load at 208/240 V output to an electric vehicle, 65 or 70 A breakers are required.

Wiring must be sized in accordance with NEC code for continuous load devices. Typically, 16 mm<sup>2</sup> or 10 mm<sup>2</sup> (6 AWG or 8 AWG) insulated electrical wire is used, depending upon the rating of the circuit and the distance between the electrical panel and the charger. The terminal block accepts a maximum of 16 mm<sup>2</sup> (6 AWG).

## 240 VAC Panel

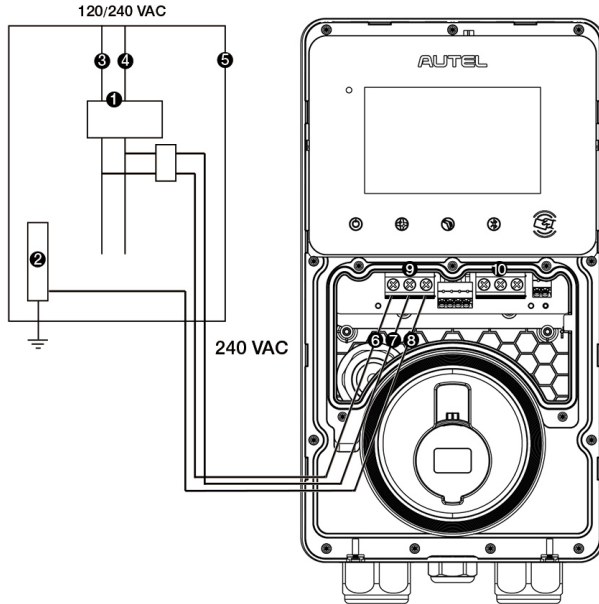

1. Main Breaker
2. PE Bus
3. L1
4. L2
5. Local Service or Sub Panel
6. L1
7. L2
8. PE
9. Input Terminal Block
10. Output Terminal Block

## 208 VAC Panel

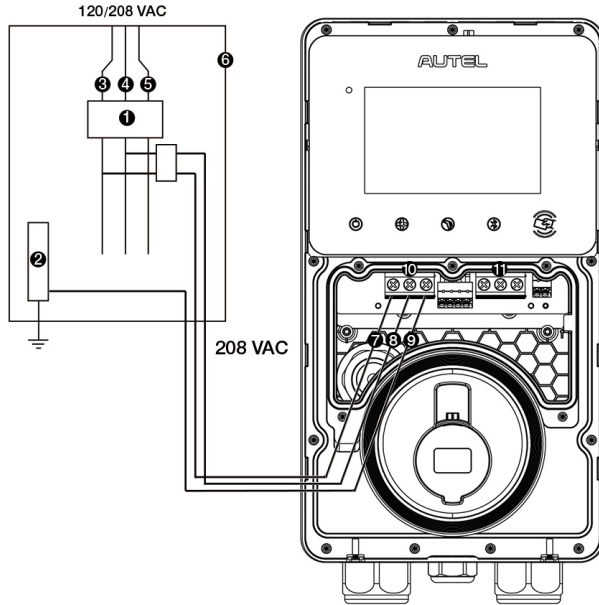

1. Main Breaker
2. PE Bus
3. L1
4. L2
5. L3
6. Local Service or Sub Panel
7. L1
8. L2
9. PE
10. Input Terminal Block
11. Output Terminal Block

### 3.2.2 Grounding Requirements

The charger must be connected to a grounded, metal, and permanent wiring system. An equipment-grounding conductor must be run with circuit conductors and connected to an equipment-grounding terminal or lead on the charger.

A grounding conductor that complies with applicable codes must be grounded to earth at the service equipment or, when supplied by a separate system, at the supply transformer.

Neutral is not used to power the charger but must be properly connected to ground, at the panel transformer, to provide necessary voltage reference relative to ground.

## 3.3 Preparing for Installation

---

### 3.3.1 Location

- Install your charger on a flat and vertical surface capable of supporting its weight (e.g., a finished wall or pedestal). The maximum weight of a MaxiCharger AC Wallbox Commercial is approximately 14.8 lbs. (6.7 kg).
- Install the charger in a location that allows the charging cable to remain within its bending tolerance.
- Position the charger in a location where it is not vulnerable to being damaged.
- Ensure the electrical panel supports a 240 V dedicated circuit with a new, dedicated, and non-GFCI two-pole circuit breaker, in accordance with local codes and ordinances.
- The recommended installation height is between 51 and 67 inches (1300 and 1700 mm).

## 3.4 Installing the Charger

---

The MaxiCharger AC Wallbox Commercial supports both rear entry and bottom entry wiring. Choose the most appropriate wiring entry for your charger based on the placement of the wiring.

---

### DANGER

Risk of shock. Switch off all electrical power prior to installation. Do not switch it on until all the installation work is completed.

---

---

### IMPORTANT

- Both the rear entry and bottom entry locations are on the left side of the charger. Ensure that you mount your charger in a location where the power supply wiring can be easily accessed on the left side.
  - The rear entry cables should be put through the cable inlet holes prior to mounting the charger to the wall dock.
  - After the charger is installed, contact Autel support to complete the cloud setup for the charger to ensure its normal operation.
-

## Placement

1. Find the wall stud nearest to and on the right side of the power supply wiring using a wall stud finder.
2. Draw a vertical line of approximately 20" (50 cm) in line with the wall stud at the approximate height of your mounting.

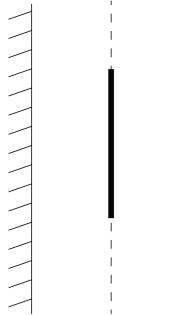

3. Place the wall dock with the center holes aligned with the vertical line. Mark the two lower mounting holes (A) and remove the wall dock.

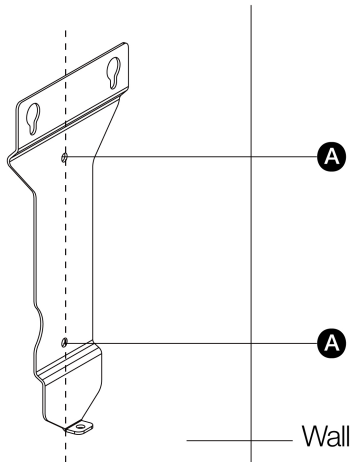

4. For rear entry wiring, mark the cable exit where the AC input cable will come out from the wall. Ensure that the cable exit matches the wall dock notch according to the diagram below.

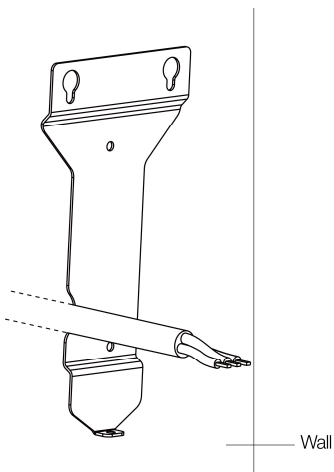

### Mounting the Wall Dock

1. Drill two 5/16" holes and insert two 5/16" diameter wall anchors into the lower mounting holes.
2. Attach the wall dock to the mounting location by screwing two M6 x 50 screws (B) into the lower mounting holes. Tighten the screws using the type PH2 screwdriver (not included in the package).

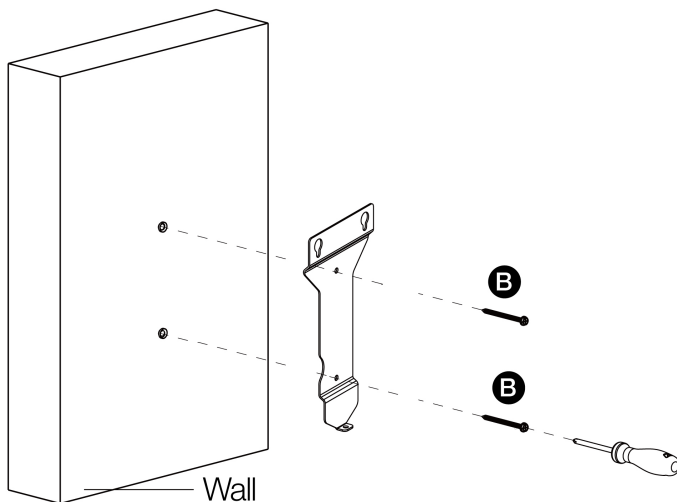

## Preparing for Installation

Remove the covers from the charger by removing the screws using the type T10 screwdriver.

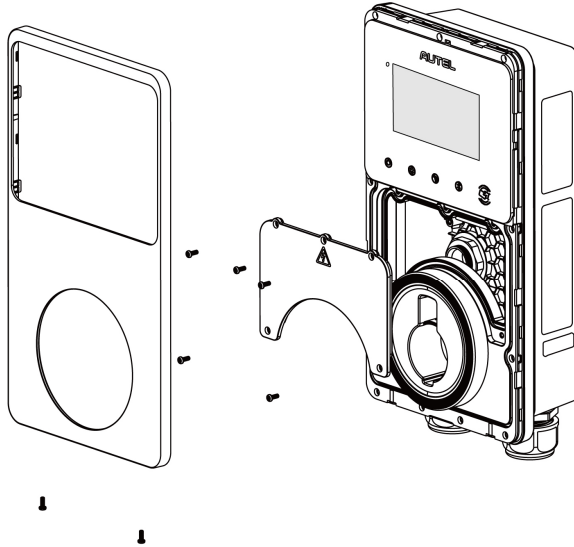

## Power Supply Wiring

### ⚠ IMPORTANT

- Use copper conductors with the maximum wire size of 6 AWG (16 mm<sup>2</sup>).
- Ensure that the screws for the terminal blocks are properly tightened.
- Ensure that there is no copper wire or debris left inside of the charger before switching on the electrical power to the charger.

### Step 1

#### Rear Entry

1. Remove the rear entry power conduit plug from the charger and replace it with the 3/4" conduit fitting (C, not included in the package).
2. Insert the AC input cable into the conduit fitting and attach the conduit fitting to the charger.
3. Screw the nut (D) into the conduit fitting.

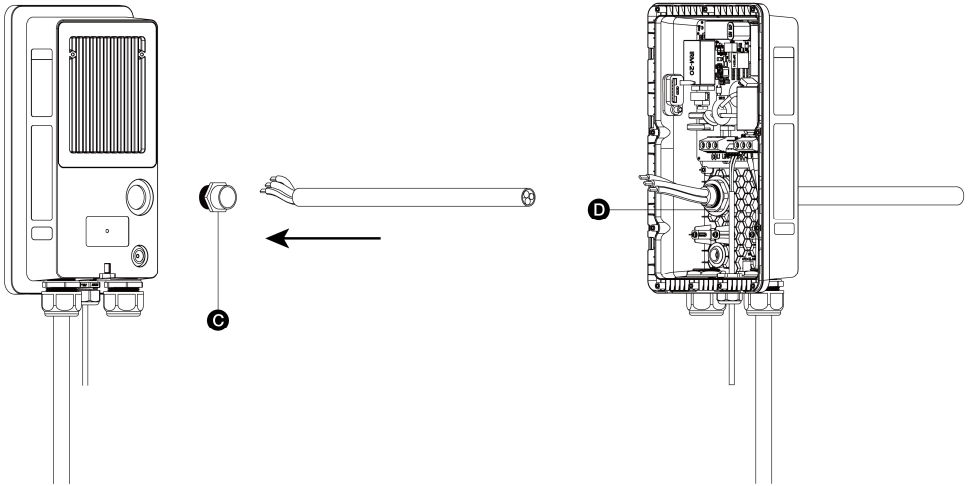

4. Remove the lower-left cable gland and install the bottom entry power conduit plug (E) to the charger.

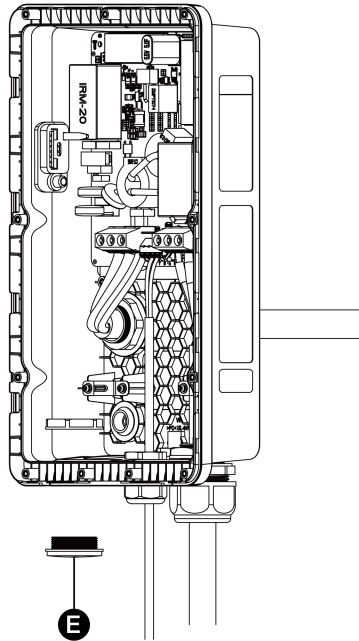

## Bottom Entry

Loosen the cable gland on the left (F) and insert the AC input cable into the inlet hole.

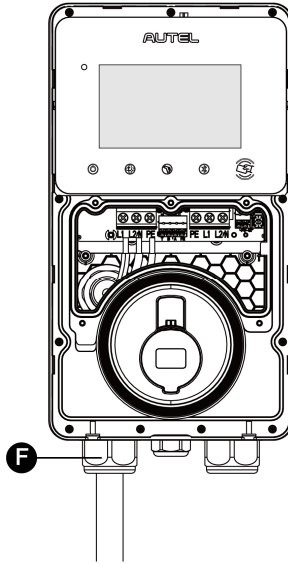

## Step 2

1. Strip the wires to 1/2" (12 mm).
2. Connect the wires (L1, L2, and Ground) according to the diagram below and tighten each connector screw to 2 N·m (17.7 in·lbs).
3. Reinstall the covers and tighten the screws.

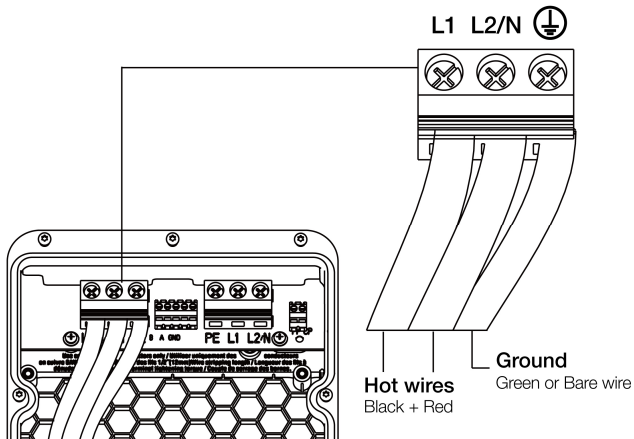

## Mounting the Charger

1. Attach the charger to the wall dock by inserting the mounting screws (G) on the back of the charger into the two upper mounting holes (H). Slide the charger downwards.

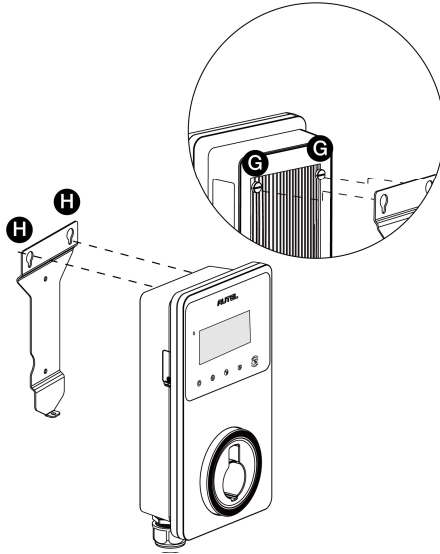

2. Screw the M5 x 12 screw (I) into the hole at the bottom of the charger and tighten the screw to secure the charger using the type T25 screwdriver.

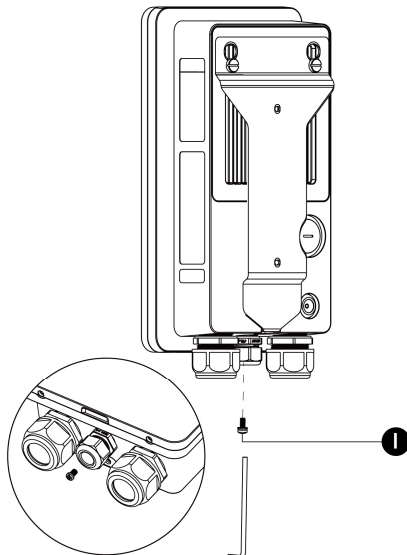

## Connecting to the Internet

The charger can be connected to the Internet by Ethernet cable, Wi-Fi or a SIM card (Verizon, T-Mobile, and ATT are all supported).

### Via the Ethernet cable:

#### Step 1

#### Rear Entry

1. Pierce the rubber grommet and put the Ethernet cable (J) through it.
2. Make a RJ45 plug and connect it with the Ethernet cable.

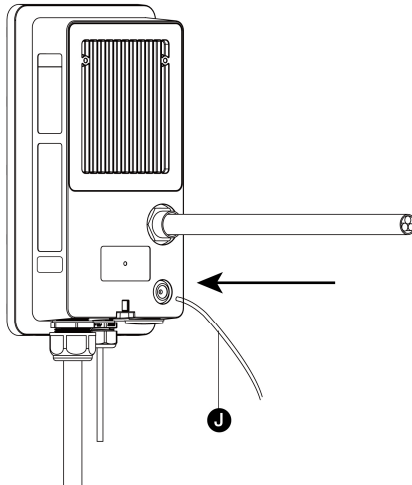

#### Bottom Entry

Put the Ethernet cable with the RJ45 plug through the bottom Ethernet cable port (K).

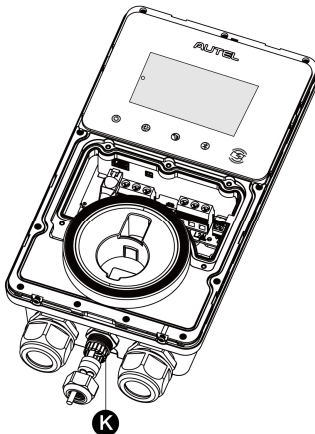

## Step 2

Plug the cable into the RJ45 port as shown.

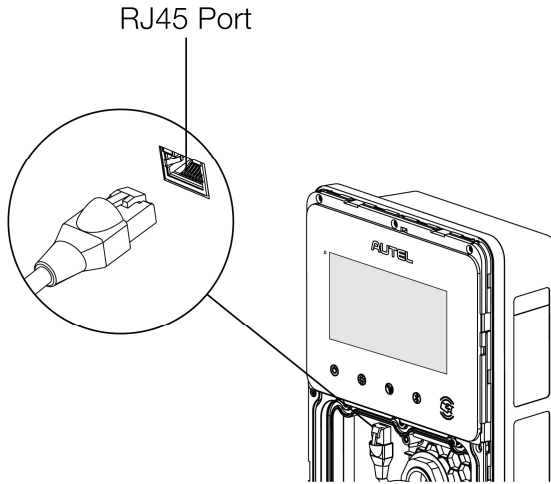

### Via the SIM card:

Remove the SIM card cover by first unscrewing the M3 x 10 screw using the type T10 screwdriver. Then, eject the SIM card tray by pressing the tiny button next to the SIM card tray cover using the screwdriver and place the card into it. Make sure that the card is inserted correctly. Reinstall the SIM card cover by following the procedures above in reverse order.

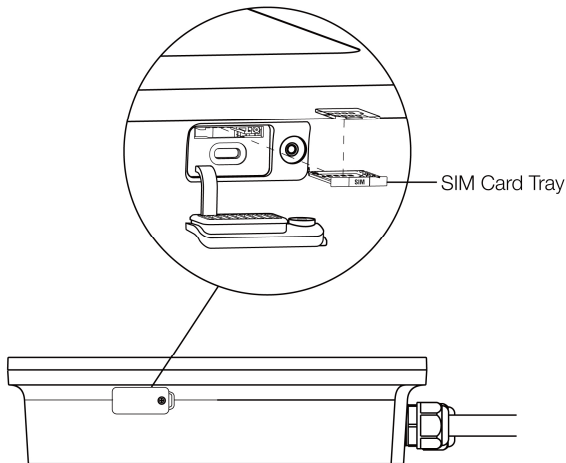

## RS485 Cables Wiring (Optional)

If you need to connect the RS485A and RS485B cables, insert the cables through the bottom Ethernet cable port (G) first. Then connect the cables to the RS485 port as specified on the terminal block, respectively.

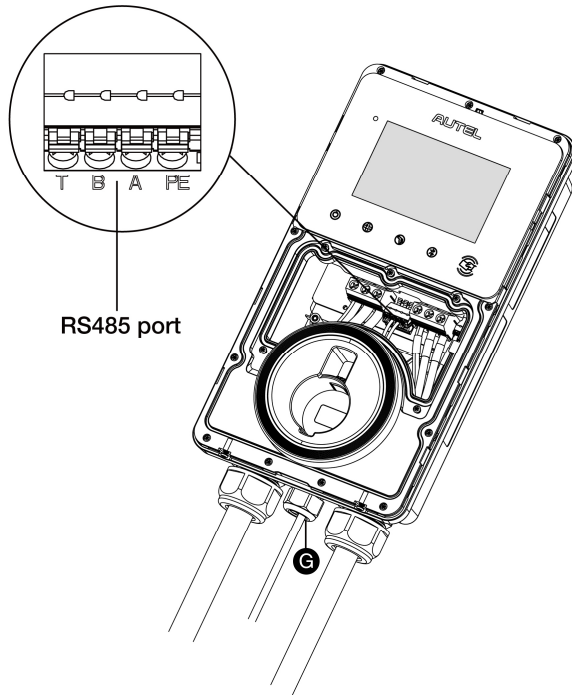

## Adjusting the Rated Current

The MaxiCharger AC Wallbox Commercial allows you to manually set a lower maximum current using a current selector when installing your charger on a circuit rated lower than the maximum rating for your charger.

1. Remove the covers and locate the current selector.
2. Use a flathead screwdriver to set the rotary switch to the appropriate position (refer to the table below).

Position	Amperage (A)	Circuit Breaker Rating
0	Not in Use	N/A
1	16	20
2	24	30
3	32	40
4	40	50
5	48	60
6	50	70
7	Not in Use	N/A
8	Not in Use	N/A
9	Not in Use	N/A

---

### NOTE

When the rotary switch is at 0, 7, 8 or 9, the corresponding amperage will still be 16, 50, 50, and 50, respectively.

---

3. When the current of your charger is set lower than the maximum rating, choose the correct current value from the Amperage Labels and affix it over the existing label on the charger.

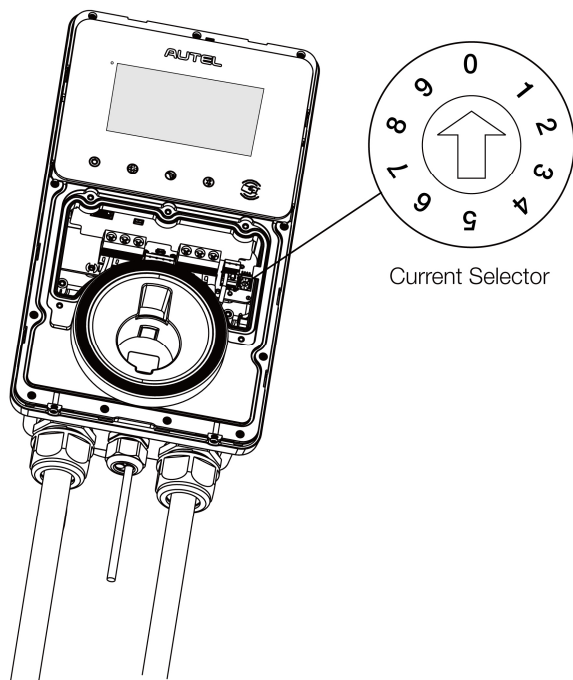

---

**⚠ CAUTION**

To reduce the risk of fire, only connect your charger to a circuit with a branch circuit over-current protection of 125% of the selected maximum amperage setting of the device in accordance with ANSI/NFPA 70 (US) CSA 22.1 (Canada).

---

**Powering on the Charger**

Once all the electrical connections have been safely made, switch on the power to the circuit from the circuit breaker and wait for the power supply to come on. There will be a series of self-check starts, making sure that the charger works correctly and safely. The power LED should illuminate green.

# 4 Troubleshooting and Service

## 4.1 Troubleshooting Table

Item	Problems	Solutions
1	The charger is successfully added, but the Bluetooth connection fails.	Check whether the QR code on the charger is consistent with the QR code on the Installation Guide. If so, make sure the Bluetooth is enabled on your mobile device; if not, contact customer support.
2	The charge session does not start as scheduled.	Do not insert the connector into your EV charging port before setting up a charging schedule for the first time. Insert the EV charging cable after the schedule is set up.
3	Over-voltage	Use the multimeter to check whether the voltage on the power input is too high. If the result is greater than or equal to 115 % of the rated voltage (276 V), contact local power grid company.
4	Under-voltage	Use the multimeter to check whether the voltage on the power input is not sufficient. If the result is less than or equal to 70 % of the rated voltage (161 V), contact local power grid company.
5	Ground fault	Make sure the charger is grounded correctly.
6	Power failure	Make sure the switch to the circuit breaker is on.

Item	Problems	Solutions
7	Over-heating	<ul style="list-style-type: none"> <li>● Check whether the EV charging cable is securely connected.</li> <li>● Ensure the operating temperature is within the specified range on the product label.</li> <li>● Stop charging. Restart charging until it is within the operation temperature range.</li> </ul>
8	Residual current detected	Unplug the vehicle and plug in again. If the problem persists, contact customer support.
9	Bluetooth communication failure	<ul style="list-style-type: none"> <li>● Make sure the Bluetooth is enabled on your mobile device and the charger is powered on and operating properly.</li> <li>● Forget the charger in the Bluetooth settings on your mobile device and pair the charger to your device via Bluetooth again.</li> <li>● If the problem persists, contact customer support.</li> </ul>
10	Update failure via Bluetooth	<ul style="list-style-type: none"> <li>● Make sure the charger is in idle status.</li> <li>● Make sure the Bluetooth connection is working properly.</li> <li>● If the problem persists, contact customer support.</li> </ul>
11	Internet connection fails	<ul style="list-style-type: none"> <li>● Try to connect another device to the same Internet, verifying the Internet connection is working properly.</li> <li>● If the problem persists, contact customer support.</li> </ul>

## 4.2 Service

---

If you cannot find solutions to your problems with the aid from the table above, please contact our technical support.

### AUTEL

- **Website:** [www.autelenergy.com](http://www.autelenergy.com)
- **Phone:** (844) 765-0150
- **Email:** [evsupport@autel.com](mailto:evsupport@autel.com)
- **Address:** 36 Harbor Park Drive, Port Washington, New York, USA 11050

# 5 Compliance

## **FCC regulatory conformance:**

This device complies with Part 15 of the FCC Rules. Operation is subject to the following two conditions:

- (1) This device may not cause harmful interference.
- (2) This device must accept any interference received, including interference that may cause undesired operation.

**NOTE:** This equipment has been tested and found to comply with the limits for a Class B digital device, pursuant to part 15 of the FCC Rules. These limits are designed to provide reasonable protection against harmful interference in a residential installation.

This equipment generates uses and can radiate radio frequency energy and, if not installed and used in accordance with the instructions, may cause harmful interference to radio communications. However, there is no guarantee that interference will not occur in a particular installation. If this equipment does cause harmful interference to radio or television reception, which can be determined by turning the equipment off and on, the user is encouraged to try to correct the interference by one or more of the following measures:

- Reorient or relocate the receiving antenna.
- Increase the separation between the equipment and receiver.
- Connect the equipment into an outlet on a circuit different from that to which the receiver is connected.
- Consult the dealer or an experienced radio/TV technician for help

**NOTE:** The manufacturer is not responsible for any radio or TV interference caused by unauthorized modifications to this equipment. Such modifications could void the user's authority to operate the equipment.

## **RF Exposure**

This equipment complies with FCC radiation exposure limits set forth for an uncontrolled environment. This equipment should be installed and operated with minimum distance of 20 cm between the radiator and your body. This transmitter must not be co-located or operating in conjunction with any other antenna or transmitter.

## **IC regulatory conformance:**

This device complies with CAN ICES-3 (B)/NMB-3(B).

This device contains licence-exempt transmitter(s)/receiver(s) that comply with Innovation, Science and Economic Development Canada's licence-exempt RSS(s). Operation is subject to the following two conditions:

(1) This device may not cause interference.

(2) This device must accept any interference, including interference that may cause undesired operation of the device.

Cet appareil est conforme à la norme CAN ICES-3 (B)/NMB-3 (B).

Cet appareil contient des émetteurs / récepteurs exempt (s) de licence qui sont conformes aux RSS exemptes de licence d'Innovation, Sciences et Développement économique Canada. Son fonctionnement est soumis aux deux conditions suivantes:

(1) Cet appareil ne doit pas provoquer d'interférences.

(2) Cet appareil doit accepter toute interférence, y compris les interférences susceptibles de provoquer un fonctionnement indésirable de l'appareil.

### **RF Exposure**

This equipment complies with IC radiation exposure limits set forth for an uncontrolled environment. This equipment should be installed and operated with minimum distance of 20 cm between the radiator and your body. This transmitter must not be co-located or operating in conjunction with any other antenna or transmitter.

Cet équipement est conforme aux limites d'exposition aux rayonnements de la IC établies pour un environnement non contrôlé. Cet équipement doit être installé et fonctionner à au moins 20cm de distance d'un radiateur ou de votre corps.