

Power Block and Power Link 2000

Express Plus DC Fast Charging Platform

Site Design Guide



IMPORTANT SAFETY INSTRUCTIONS

SAVE THESE INSTRUCTIONS

This manual contains important instructions for ChargePoint® products that shall be followed during installation, operation and maintenance of each product.

WARNING:



1. **Read and follow all warnings and instructions before servicing, installing, or operating the ChargePoint® product.** Install and operate only as instructed. Failure to do so may lead to death, injury, or property damage, and will void the Limited Warranty.
2. **Only use licensed professionals to install your ChargePoint product and adhere to all national and local building codes and standards.** Before installing the ChargePoint product, consult with a licensed contractor, such as a licensed electrician, and use a trained installation expert to ensure compliance with local building and electrical codes and standards, climate conditions, safety standards, and all applicable codes and ordinances. Inspect the product for proper installation before use.
3. **Always ground the ChargePoint product.** A touch current of >3.5 mA AC RMS is possible in case of a fault condition of loss of electrical continuity of the earthing conductor. Failure to ground the product can lead to risk of electric shock. The product must be connected to a grounded, metal, permanent wiring system, or an equipment grounding conductor shall be run with circuit conductors and connected to the equipment grounding terminal or lead on the Electric Vehicle Supply Equipment (EVSE). Connections to the EVSE shall comply with all applicable codes and ordinances.
4. **Install the ChargePoint product using a ChargePoint-approved method.** Failure to install on a surface that can support the full weight of the product can result in death, personal injury, or property damage. Inspect the product for proper installation before use.
5. **The product is not suitable for use in Class 1 hazardous locations, such as near flammable, explosive, or combustible vapors or gases.**
6. **Supervise children near this device.**
7. **Do not put fingers into the electric vehicle connector or connector adapter. Do not touch fingers to charging rails.**
8. **Do not use this product if any cable is frayed, has broken insulation, or shows any other signs of damage.**
9. **Do not use this product if the enclosure, the flexible output cable, the vehicle inlet, the electric vehicle connector, or the electric vehicle connector adapter is broken, cracked, open, or shows any other signs of damage. Do not use this product if internal parts are accessible, including wiring.**
10. **Wire and wire terminal information are provided in the ChargePoint product Site Design Guide and Installation Guide.**

11. **Torques for installation of wire terminals are provided in the ChargePoint product Installation Guide.**
12. **The ChargePoint product maximum operating temperature is 50 °C (122 °F).**
13. **Do not use an electric vehicle connector adapter with any charger or EV that is capable of exceeding the adapter's rated voltage of current capacity. Some EVs and EVSE combinations are capable of multiple voltages or limited durations of current overloading designed for normal EVSE-to-EV connections. Use of an electric vehicle connector adapter in these situations could result in unsafe conditions such as fire, burns, or exposure of high voltage.**



IMPORTANT: Under no circumstances will compliance with the information in a ChargePoint guide such as this one relieve the user of the responsibility to comply with all applicable codes and safety standards. This document describes approved procedures. If it is not possible to perform the procedures as indicated, contact ChargePoint. ChargePoint is not responsible for any damages that may result from custom installations or procedures not described in this document or that fail to adhere to ChargePoint recommendations.

Product Disposal

Applicable to NA - Do not dispose of as part of unsorted domestic waste. Inquire with local authorities regarding proper disposal. Product materials are recyclable as marked.



Applicable to EU - To comply with Directive 2012/19/EU of the European Parliament and of the Council of 4 July 2012 on waste electrical and electronic equipment (WEEE), devices marked with this symbol may not be disposed of as part of unsorted domestic waste inside the European Union. Enquire with local authorities regarding proper disposal. Product materials are recyclable as marked.



Document Accuracy

The specifications and other information in this document were verified to be accurate and complete at the time of its publication. However, due to ongoing product improvement, this information is subject to change at any time without prior notice. For the latest information, see our documentation online at [ChargePoint Product Reference Documentation](#).

Copyright and Trademarks

©2013-2026 ChargePoint, Inc. All rights reserved. This material is protected by the copyright laws of the United States and other countries. It may not be modified, reproduced, or distributed without the prior, express written consent of ChargePoint, Inc. ChargePoint and the ChargePoint logo are trademarks of ChargePoint, Inc., registered in the United States and other countries, and cannot be used without the prior written consent of ChargePoint.

Symbols

This guide and product use the following symbols:



DANGER: Risk of electric shock



WARNING: Risk of personal harm or death



CAUTION: Risk of equipment or property damage



IMPORTANT: Critical detail that must be followed to achieve intended results



NOTE: Important contextual details or procedural clarifications



REINSTALL NOTE: Essential instructions to follow when reinstalling a part or component



Read the manual for instructions



Ground/protective earth

Illustrations Used in This Document

The illustrations used in this document are for demonstration purposes only and may not be an exact representation of the product. However, unless otherwise specified, the underlying instructions are accurate for the product.

Contents

- IMPORTANT SAFETY INSTRUCTIONS i
- Revision History vi
- 1 Introduction 1**
 - Express Plus Components 1
 - Express Plus System Overview 1
 - Power Block and Pedestal-Mount Power Link 2000 Configurations 7
 - Wall and Overhead-Mount Power Link 2000 Configurations 8
 - Express Plus Guides 11
 - Questions 12
- 2 Site Design Guidelines 13**
 - Initial Site Guidelines 13
 - Plan for Future Charging Capacity 13
 - System Placement 14
- 3 Civil and Mechanical Design 20**
 - Weights 20
 - Dimensions 20
 - Pedestal-Mount Specifications 30
 - Wall or Overhead-Mount Specifications 43
 - Drainage 48
 - Flood Plane 48
 - Clearances 49
 - Wheel Stops and Bollards 51
 - Ventilation 53
 - Accessibility 55
 - Signage 55
- 4 Electrical Design 56**
 - Power Block Electrical Supply Requirements 57
 - Grounding Requirements 59
 - Power Link 2000 Site Considerations 60
 - Wiring Requirements 62
- 5 Connectivity 72**

Signal Strength and Quality 72

Repeaters 74

Revision History

This page provides a summary of revisions made, listing the month and year of each update along with a brief description of the changes made.

Month & Year	Description
January, 2026	In the Clearance section, added the anchor bolt-to-anchor bolt dimension for the power block CMT.
September, 2025	In section Electrical Design , added information related to auto transformers and neutral-to-ground bonding.
July, 2025	Included additional safety instructions in the IMPORTANT SAFETY INSTRUCTIONS .

Introduction 1

This section provides an introduction to the ChargePoint® Express Plus Power Block and Power Link 2000.

Express Plus Components

Express Plus is a scalable DC fast charging platform that is based on the modular building blocks outlined below.

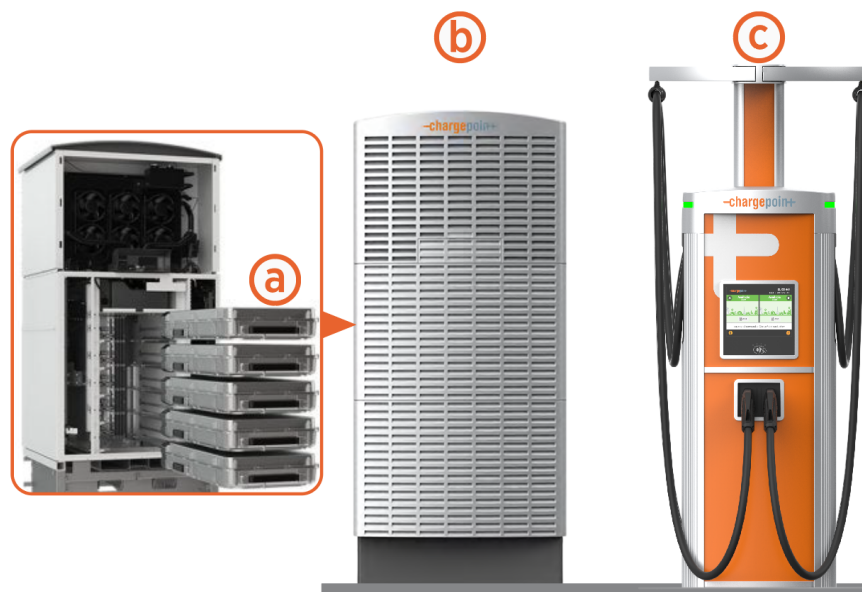

- (a)** Power Module: Self-contained AC to DC power conversion system that operates an output of between 100 and 1000 V and delivers up to 40 kW of power.
- (b)** Power Block: Power cabinet that houses up to five Power Modules and supplies DC output power to Power Link 2000s. Each Power Block can output up to 200 kW of power.
- (c)** Power Link 2000: Dispenser that delivers DC power to EVs through flexible, lightweight charging cables equipped with industry standard connectors such as CCS1, CCS2, CHAdeMO, MCS, and NACS. The Power Link 2000 can accommodate up to two charging cables to charge two electric vehicles simultaneously or sequentially. Built-in cellular networking enables remote management via the ChargePoint Platform Dashboard.

Express Plus System Overview

Express Plus consists of the following components:

Power Block

Power Block block diagram:

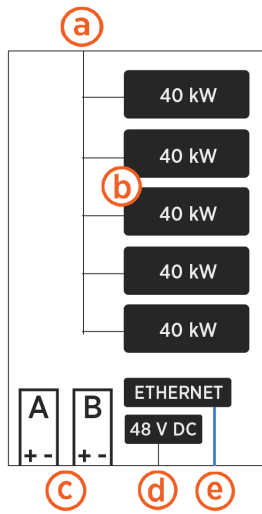

- (a)** Three phase AC power input
- (b)** Configurable with up to five 40 kW Power Modules for a maximum total output of 200 kW
- (c)** Two available HV DC power outputs (A and B)
- (d)** 48 V DC power output
- (e)** Ethernet output

The Power Block is an enclosure structured with an upper and lower enclosure, stacked on a pedestal:

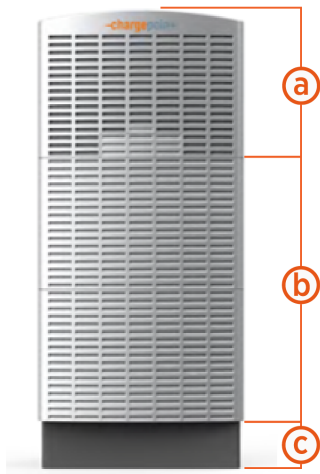

- (a)** Upper enclosure: Auxiliary power supply and temperature management components
- (b)** Lower enclosure: Bay for Power Modules and bus bars to land all input and output cables
- (c)** Pedestal: Secures the Power Block and provides access for either stub-up or surface mount installations on a concrete pad

Power Link 2000

Power Link 2000 block diagram:

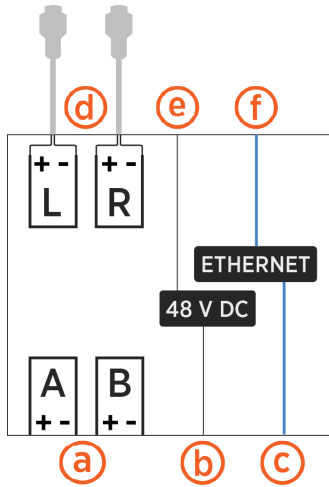

- (a) Single or dual HV DC power paths (A and B)
- (b) 48 V DC power input
- (c) Ethernet input
- (d) Single or dual HV DC charging cable outputs (L and R)
- (e) 48 V DC power output
- (f) Ethernet output

The Power Link 2000 is a vertical enclosure that is available in the following variants:

- Pedestal-Mount Power Link 2000

This enclosure is designed for mount on a concrete ground surface and is equipped with charging cable holsters and an interactive display. The enclosure is available with single or dual outputs.



- Wall-Mount Power Link 2000

This enclosure is designed for mount on a wall or other vertical-standing structure. It is equipped with cable holsters and an interactive display. The enclosure is available with single or dual outputs.



- Overhead-Mount Power Link 2000

This enclosure is designed for mount on a wall or overhead structure (such as on a gantry or from a ceiling structure). The enclosure is available with single or dual outputs.



Power Block to Power Link 2000 Architectures

Express Plus is a highly modular system wherein Power Blocks and Power Link 2000s can be interconnected in many configurations to meet various charging needs, from simultaneous charging of two vehicles at up to 600 kW by a single station to sequential charging of up to 12 vehicles.

The DC output of the Power Block is the DC input of the Power Link 2000. Each Power Block has two HV DC outputs that can be fed to a single Power Link 2000 or to two different Power Link 2000s. A simplified block diagram of a single Power Block connected to two Power Link 2000s is shown below. The Power Block also feeds 48 V DC power and Ethernet connectivity to the Power Link 2000s.

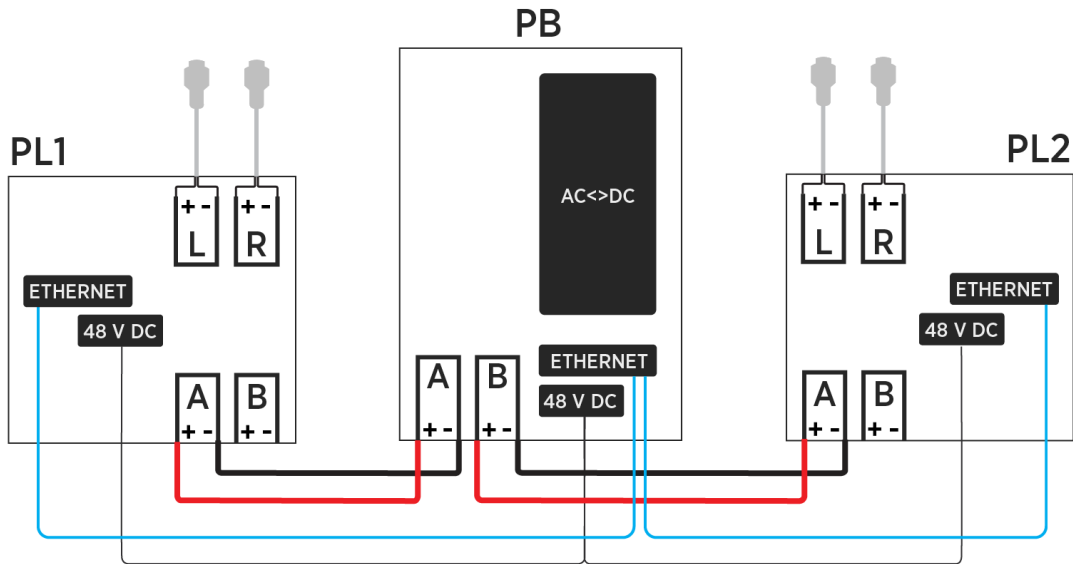

In turn, the Power Link 2000 accepts high voltage DC input from up to six Power Blocks. A simplified block diagram of a Power Link 2000 powered by two Power Blocks is shown below.

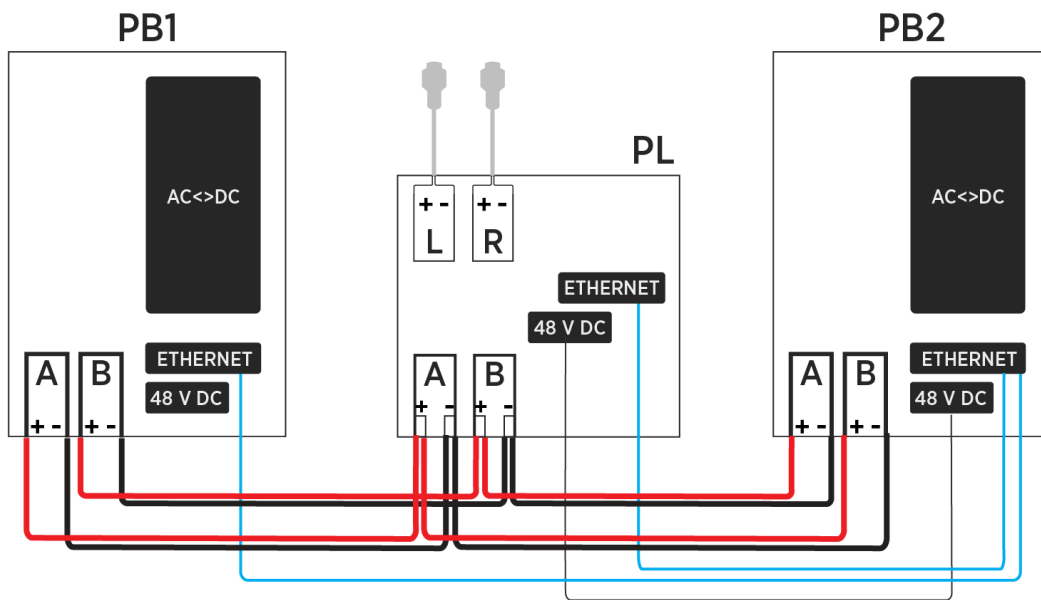

The high voltage DC output, Ethernet, and 48 V DC power output from Power Block(s) can be connected from Power Link 2000 to Power Link 2000, enabling higher port counts in specific sequential charging configurations.

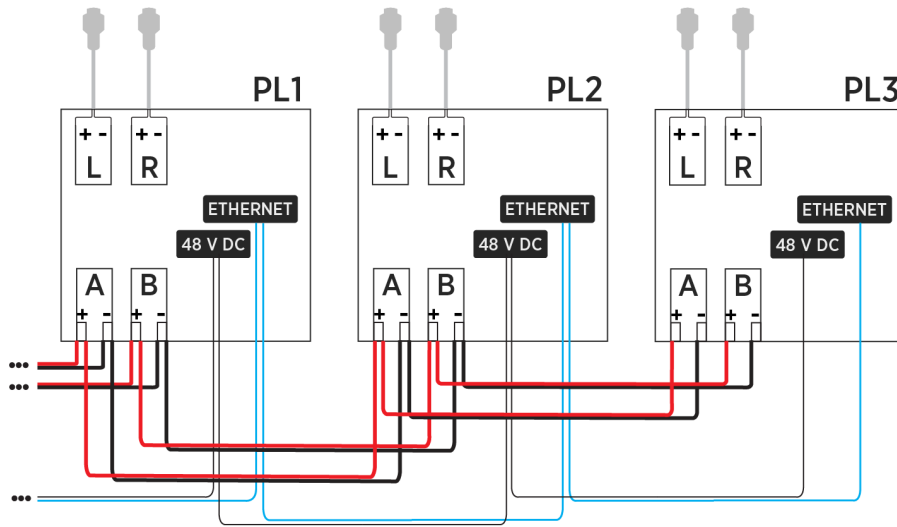

IMPORTANT: The architectures shown above demonstrate only a few of the many supported by Express Plus. The actual architecture for each site will vary depending on the number of stations, the charging capacity required at each charging station, simultaneous or sequential charging requirements, and other criteria. Contact a ChargePoint representative for the ChargePoint-approved wiring architecture for your specific project. Non-approved wiring between Power Blocks and Power Link 2000s may not enable Express Plus to function as expected.

For full specifications and certifications, refer to the *Express Plus Datasheet* at [ChargePoint Product Reference Documentation](#).

For information about Express Plus Multiplex architectures, visit [Multiplex Kit](#).

Power Block and Pedestal-Mount Power Link 2000 Configurations

The Power Block and pedestal-mount Power Link 2000 offers several configuration and installation options, described below.

Charging Cables

Depending on the charging speed and connectors required, pedestal-mount Power Link 2000s can be installed with one or two liquid-cooled cables (LCC) or non-liquid-cooled cables (non-LCC). The pedestal-mount Power Link 2000 with LCC comes with a liquid cooling system attached to the back of the enclosure.

Single or Dual LCC



Single or Dual non-LCC



Cable Management Kit (CMK)

Depending on the required cable reach, the pedestal-mount Power Link 2000 can be installed with a standard CMK to manage standard length (5.8 m or 19 ft) charging cables, or with a tall CMK or overhead CMK to manage medium length (7.6 m or 25 ft) charging cables.

Standard CMK



Tall CMK



Overhead CMK



Wire Entry

- Stub-up entry: Wires can enter pedestal-mount Power Link 2000s and Power Blocks through the bottom of the enclosures via conduits or armored cables laid underground.
- Surface entry: At sites where the wires cannot be laid underground, they can enter into pedestal-mount Power Link 2000s and Power Blocks through the rear side of the enclosures via conduits or armored cables laid above ground.



NOTE: Power Link 2000s and Power Blocks used in a Multiplex architecture cannot use surface entry wiring. For more information, refer to the *Power Link 2000 Site Design Guide* at [ChargePoint Product Reference Documentation](#).

Wall and Overhead-Mount Power Link 2000 Configurations

The wall- and overhead-mount Power Link 2000 offers several configuration and installation options, described below.

Charging Cables

Wall and overhead-mount Power Link 2000s can be installed with one or two non-liquid cooled cables (non-LCC). They do not support liquid-cooled cables (LCC).

Single Non-LCC



Dual Non-LCC



Cable Management Kit (CMK)

- Wall-Mount:

A wall-mount Power Link 2000 can be installed with a standard CMK to manage standard length (5.8 m or 19 ft) charging cables or with a tall CMK to manage medium length (7.6 m or 25 ft) charging cables.

Standard CMK



Tall CMK



- Overhead-Mount:

An overhead-mount Power Link 2000 can be installed with an overhead CMK to manage medium length (7.6 m or 25 ft) charging cables.

Overhead CMK



Wire Entry

The wires enter into wall and overhead-mount Power Link 2000 from the bottom side, through conduits or armored cables laid above ground.

Express Plus Guides

Access ChargePoint documents at [ChargePoint Product Reference Documentation](#).

Document	Content	Primary Audiences
Datasheet	Full station specifications	Site designer, installer, and station owner
Site Design Guide	Civil, mechanical, and electrical guidelines to scope and construct the site	Site designer or engineer of record
Concrete Mounting Template Guide	Instructions to embed the charging station template in a concrete pad with anchor bolts and conduit placement (these may also be included in the Site Design Guide)	Site construction contractor
Surface Conduit Entry Kit Guide	Instructions for sites where conduit cannot be run underground	Installer
Construction Signoff Form	Checklists used by contractors to ensure the site is correctly completed	Site construction contractor

Document	Content	Primary Audiences
	and ready for product installation	
Installation Guide	Anchoring, wiring, and powering on	Installer
Operation and Maintenance Guide	Operation and preventive maintenance information	Station owner, facility manager, and technician
Service Guide	Component replacement procedures, including optional components	Service technician
Declaration of Conformity	Statement of conformity with directives	Purchasers and public

Questions

For assistance, go to chargepoint.com/support and contact technical support using the appropriate region-specific number.

Site Design Guidelines **2**

This section describes general site design guidelines for Power Block and Power Link 2000.

Initial Site Guidelines

An onsite evaluation is needed to determine the wiring and conduit requirements from the electrical panel to the proposed parking spaces, as well as to measure cellular signal levels and identify suitable locations for any necessary cellular signal booster equipment.

If you have pre-existing infrastructure or are using your own preferred electrical contractor to prepare your site, an Express Plus Construction Signoff Form completed by a ChargePoint Operations and Maintenance (O&M) partner is required to certify compliance with electrical code and to ensure everything was prepared to ChargePoint specifications.

CAUTION:



- If the charging station is not installed, commissioned, or serviced by a ChargePoint Certified Technician using a ChargePoint-approved method, it is excluded from all ChargePoint and other warranties and ChargePoint is not responsible.
- You must be a licensed electrician and complete the training at <https://www.chargepoint.com/partners/training-certification> to become ChargePoint certified and to access the ChargePoint web or app-based installer tools.

Plan for Future Charging Capacity

Designing electrical infrastructure to support current and future needs for EV charging helps avoid costly upgrades later as demand for EV charging grows.

Consider these methods to prepare a site for future charging stations in a later phase of work:

- Add extra capacity if electrical panels are being upgraded now.
- Use sub-panels as a way to shorten electrical paths.
- Maximize the conduit and conductor sizes (to product specifications) between the main electrical panel and future stations to prevent needing to re-pull wires or trenching work if the site uses underground wiring.
- Underground service wiring conduits can be pre-staged if the correct site construction is performed in advance. Allowed terminations include a distribution unit, junction box, or plugged conduit. This eases cable pulls for future stations.

System Placement

The placement of Power Link 2000 and Power Block must meet the following requirements:

- Do not install Express Plus in a Class 1 hazardous location, as classified by NEC or local codes.
- Site conditions must be compatible with the following specifications listed in the *Express Plus Datasheet*:
 - Operational altitude
 - Operating temperature
 - Operating humidity
 - Enclosure rating

To minimize costs, choose station locations that are close to the available electrical infrastructure. Selecting nearby locations help minimize long wire runs as well as any conduit or trenching work if the site uses underground wiring.



WARNING: Express Plus components must be installed on a structure that is rated to support their weight. A level concrete base is recommended for Power Block and pedestal-mount Power Link 2000, and a flat wall or gantry for wall or overhead-mount Power Link 2000, respectively. Asphalt cannot support the full weight of Express Plus components. Failure to install the Express Plus components on a suitable structure may cause it to tip over, resulting in death, personal injury, or property damage.

Layout considerations:

- Determine appropriate ground anchoring locations where concrete exists or can be installed (no asphalt surfaces).
- Consider locations where it will be easy to add future stations.
- If using conduits to pull wires, determine the best conduit layout to minimize linear conduit costs to multiple parking spaces. If possible, avoid or minimize trenching requirements, especially more costly trenching to run conduit under asphalt surfaces.
- Determine if the existing utility service and electrical panel capacity is sufficient. Identify costs for any necessary upgrades and/or a new dedicated electrical panel. ChargePoint recommends using a licensed electrician to evaluate available capacity and identify any upgrades that may be required.
- If a dedicated EV electrical panel is required, choose a panel located close to the existing electrical supply.
- Measure cellular signal levels to ensure adequate cellular coverage at the station locations. To ensure adequate signal strength in underground or enclosed parking structures, cellular repeaters may be required. For more information, see [Connectivity](#).
- ChargePoint recommends avoiding locations under trees where sap, pollen, or leaves would fall on the charging station and increase the station owner's site maintenance workload.

Guidelines for Different Parking Arrangements

- Choose adjacent parking spaces in an area with adequate lighting.
- Consider how easily drivers can find the stations they need to access.
- Check local requirements for accessibility and pathway width, sometimes called “path of travel”, to ensure that station placement does not restrict sidewalk use.
- A pad built into the head of a parking space (instead of on the sidewalk) is allowed if local code allows it compared to the minimum parking space length, and the pad meets all pad requirements listed in this document.

Cable reach

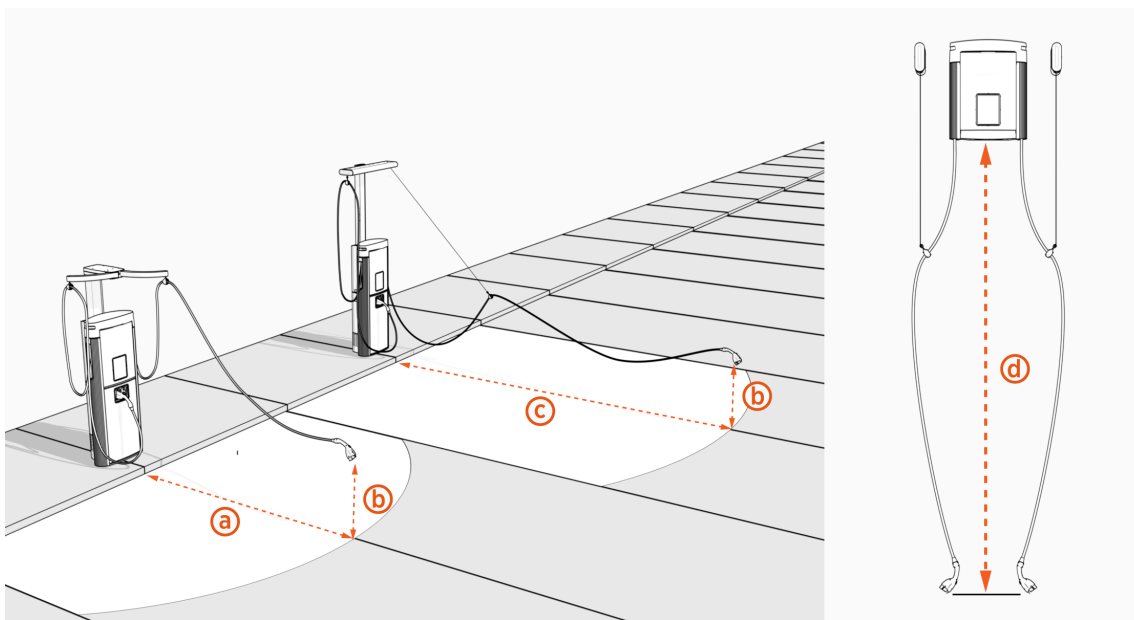

The following table provides the maximum cable reach from the station to charge port on a vehicle:



NOTE: The cable reach specifications for both the tall CMK and overhead CMK include the full extension of a tether cord from the CMKs, as depicted in the illustration above.

		Pedestal or wall-mount Power Link 2000		Overhead-mount Power Link 2000
CMK		Standard CMK	Tall CMK	Overhead CMK
Cable length		5.8 m (19 ft)	7.6 m (25 ft)	7.6 m (25 ft)
Cable reach	Horizontal or vertical reach	3.76 m (12 ft 4 in) Horizontal (a)	6.09 m (20 ft) Horizontal (c)	4.57 m (15 ft) Vertical (d)
	Height above ground	0.6 m (2 ft) (b)		Not applicable

IMPORTANT:



- Diagonal stall parking is not recommended.
- Place each Power Link 2000 to maximize cable reach for the varied charge port locations on different EVs.

Commercial or Public Station Placement, Single or Dual Cable

For stall parking, ChargePoint recommends using perpendicular parking stalls that allow a vehicle to enter either front-first or rear-first, to better accommodate the varied locations of EV charge ports.



NOTE: While ChargePoint tests charging stations with a majority of upcoming vehicles, ChargePoint cannot guarantee the port locations of future vehicles and cannot warrant the configurations proposed will work for all vehicles.

This illustration depicts a charging station with a dual cable.

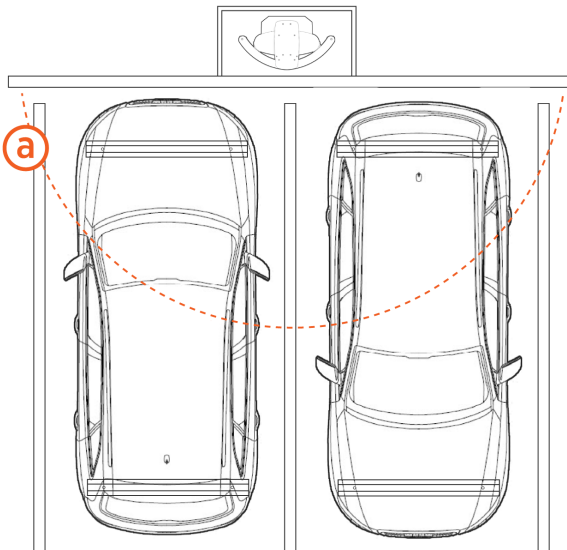

(a) Cable reach radius: 3.76 m (12 ft 4 in)

The following three illustrations depict charging stations with single cables.

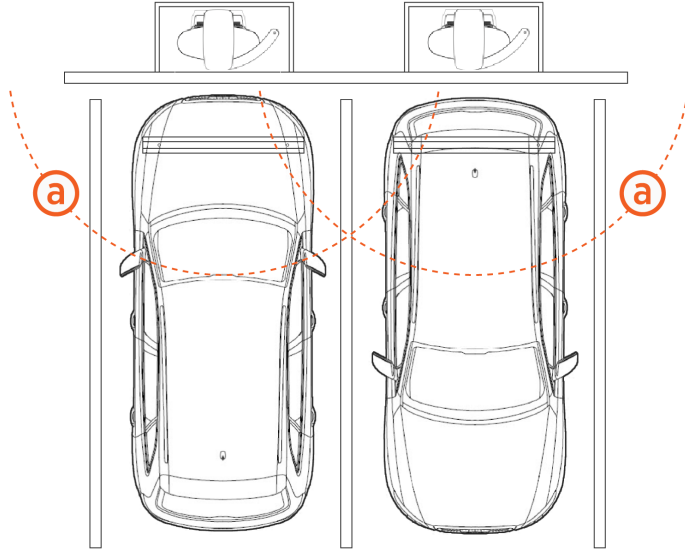

(a) Cable reach radius: 3.76 m (12 ft 4 in)

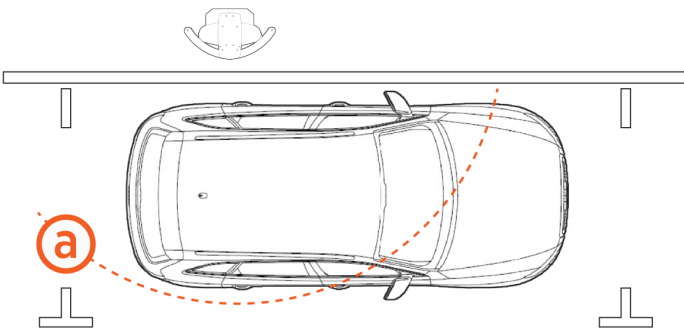
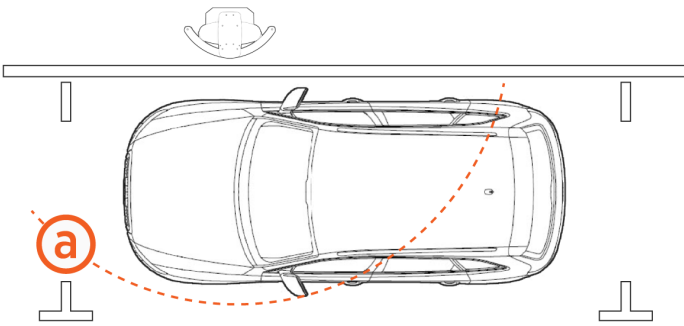

(a) Cable reach radius: 3.76 m (12 ft 4 in)

Fleet Parking Arrangement

- **Stall parking (Dual Charge Cable):** For installing dual charge cable Power Link 2000 stations, consider placing the station in front of every other parking space. Additionally, align the overhead CMK tether with the parking stripes on either side of the charging station.

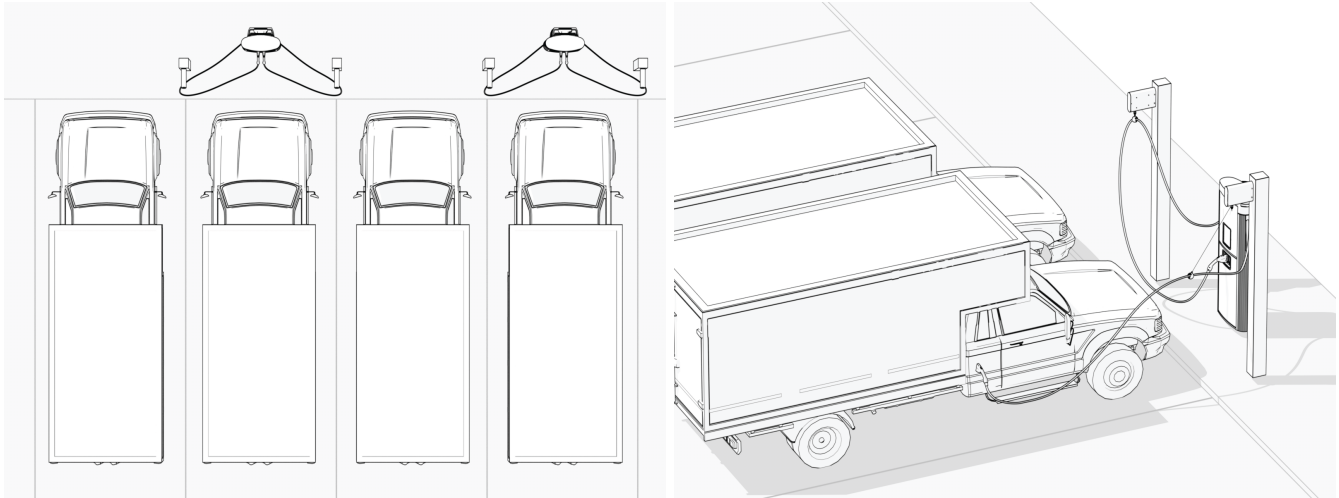

- **Stall parking (Single Charge Cable):** Power Link 2000s with single charging cables are always configured with the charging cable on the right side of the enclosure. Align the overhead CMK tether with the parking stall stripe adjacent to the vehicle's charging port. The illustrations below depict parking of the vehicles in relation to the charging stations, based on the side where the vehicle's charging port is located.

Vehicles with left-side charging ports

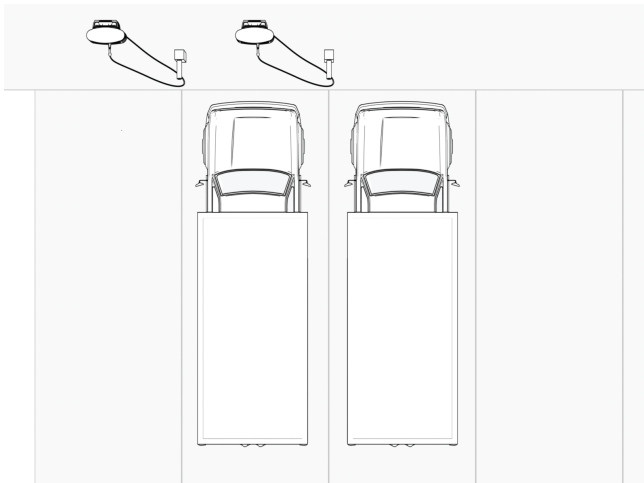

Vehicles with right-side charging ports

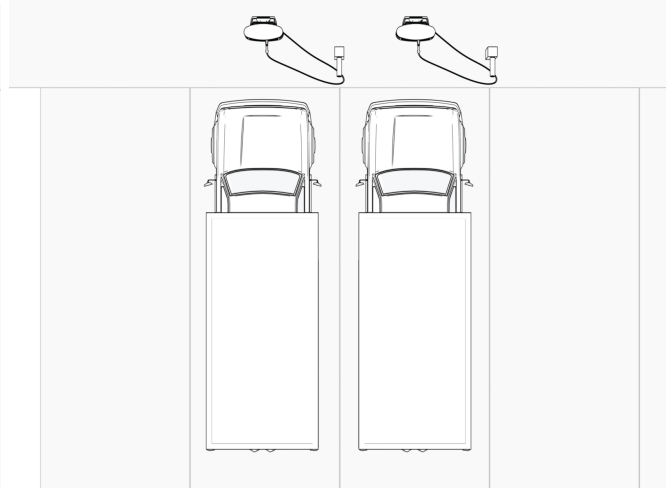

- **Island parking:** ChargePoint recommends placing a station in the center of the island facing away (station front is perpendicular to vehicles) in the same orientation. This allows the station to be accessible from both sides of the island.

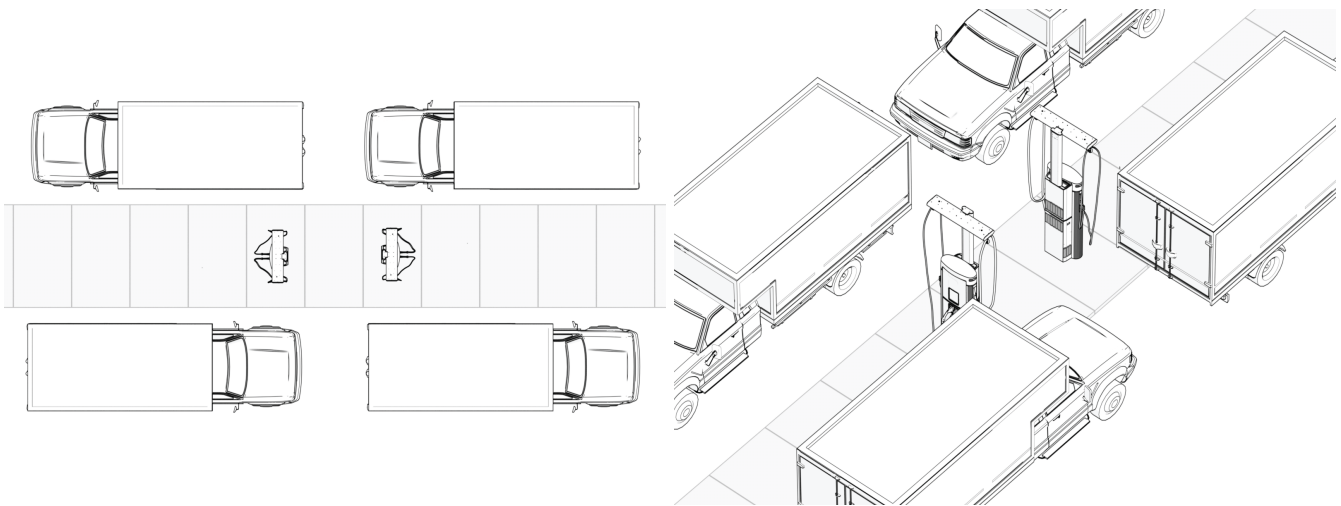

Civil and Mechanical Design 3

This section provides civil and mechanical site design information for Power Block and Power Link 2000.

Weights

Component	Weight
Power Module	45 kg (98.5 lbs)
Power Block - fully loaded with five Power Modules	680 kg (1500 lbs)
Power Link 2000 - wall or overhead-mount (excludes charging cables and CMK)	120 kg (265 lbs)
Power Link 2000 - pedestal-mount with LCC (excludes charging cables and CMK)	200 kg (441 lbs)
Power Link 2000 - pedestal-mount with non-LCC (excludes charging cables and CMK)	180 kg (400 lbs)
Power Link 2000 - wall or overhead-mount (non-LCC) (excludes charging cables and CMK)	120 kg (265 lbs)
Charging cable	16 - 37 kg (35 - 82 lbs)
Standard CMK - dual	20 kg (44 lbs)
Tall CMK - dual	38.5 kg (85 lbs)
Overhead CMK	10 kg (22 lbs)
Packaging excluded from weights listed above	45 - 90 kg (100-200 lbs)

Dimensions

This section provides the dimensions of the Power Block and Power Link 2000.

Power Block



NOTE: Images are not to scale. Measurements appear in metric units (mm) followed by imperial equivalents (inches).

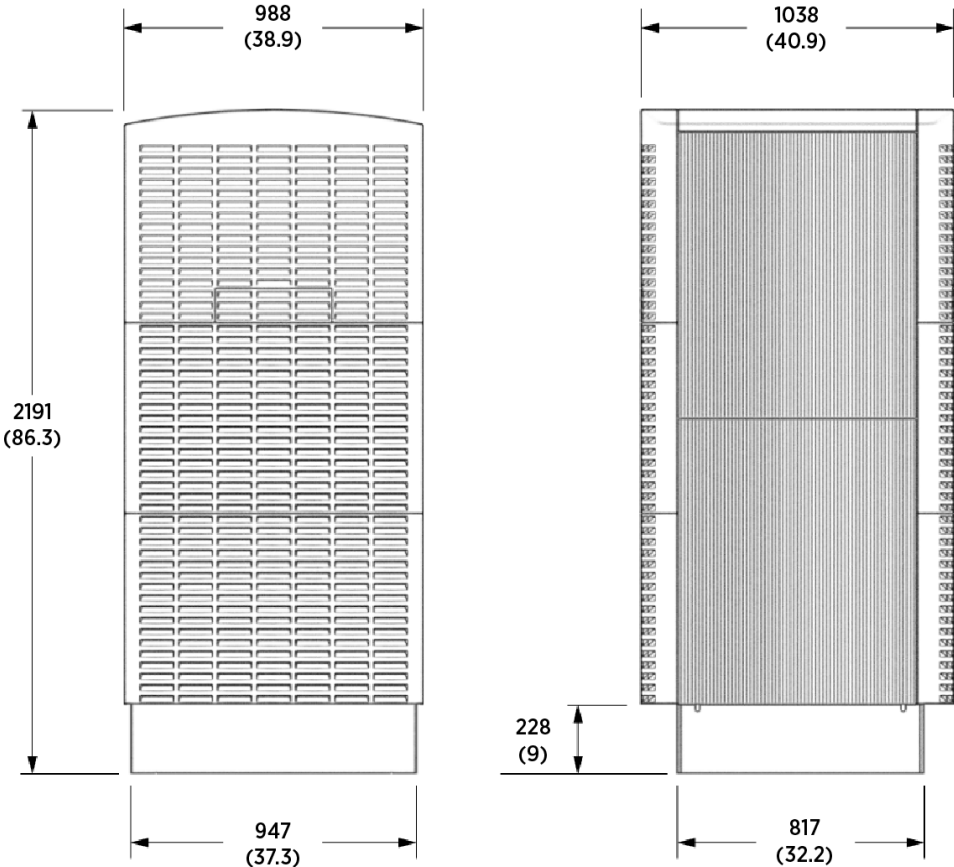

Power Link 2000

This section provides the dimensions of the Power Link 2000 in various configurations.

Pedestal-Mount Power Link 2000 With LCC, Single or Dual Cable, and Standard CMK



NOTE: Images are not to scale. Measurements appear in metric units (mm) followed by imperial equivalents (inches).

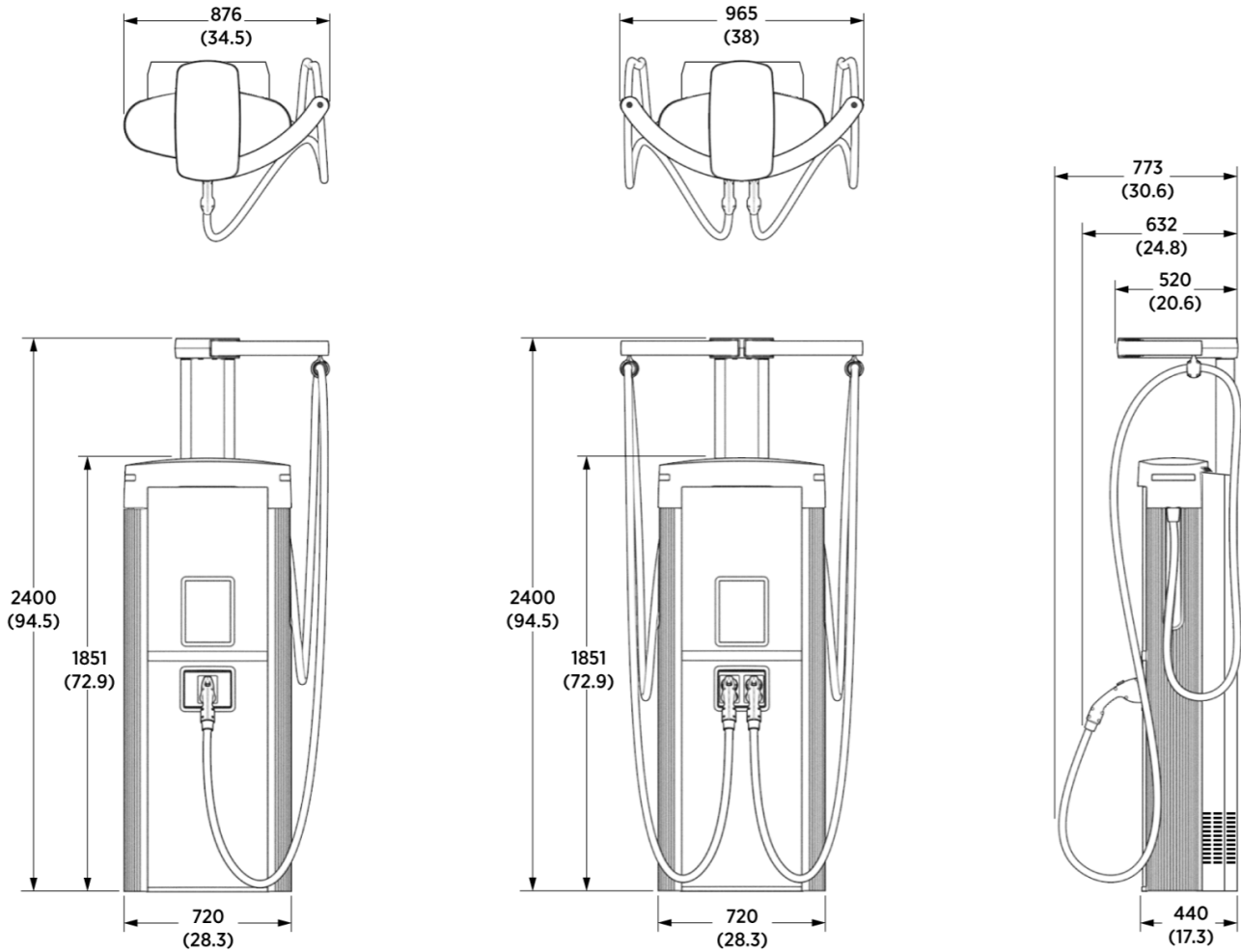

Pedestal-Mount Power Link 2000 With Non-LCC, Single or Dual Cable, and Standard CMK



NOTE: Images are not to scale. Measurements appear in metric units (mm) followed by imperial equivalents (inches).

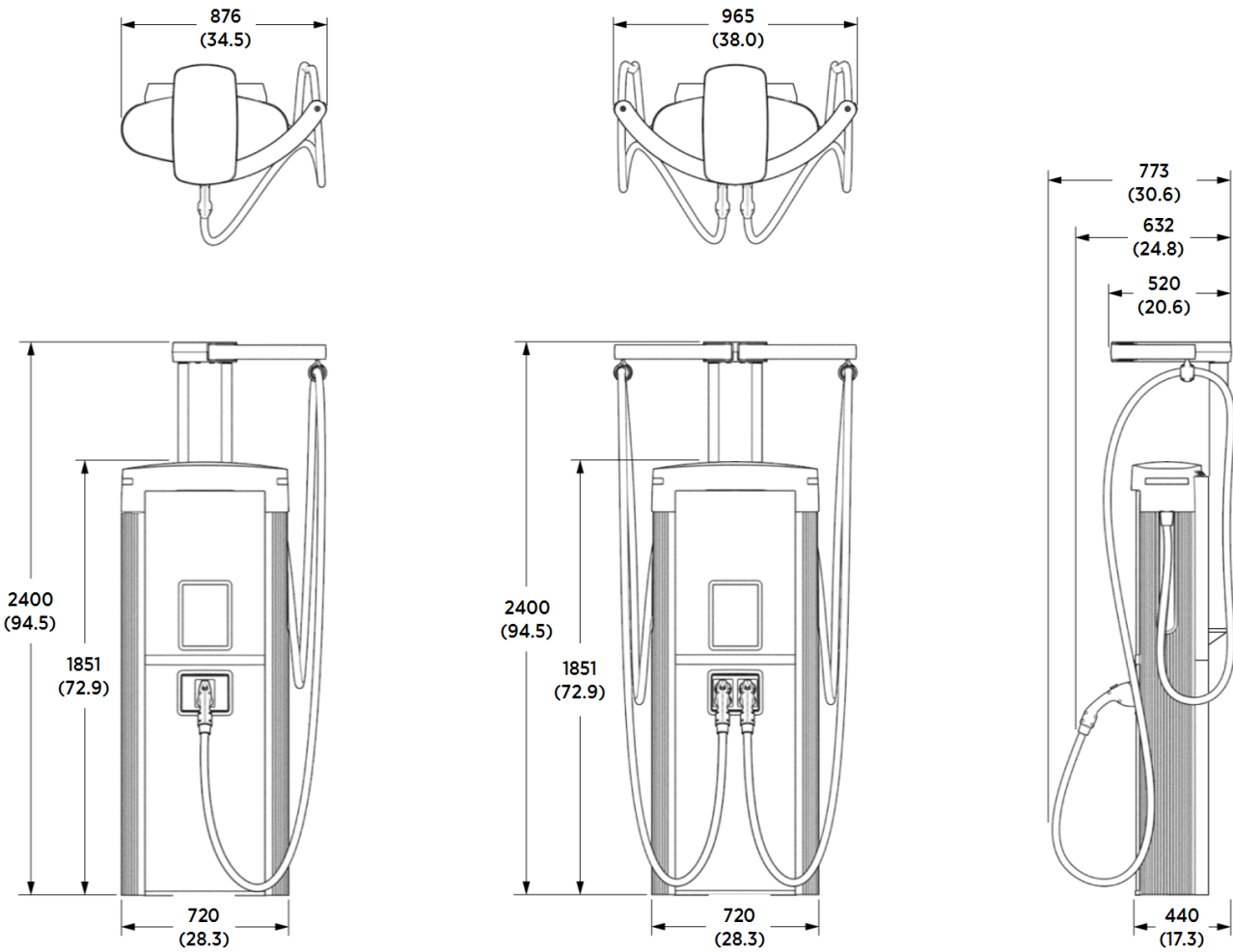

Pedestal-Mount Power Link 2000 With Non-LCC, Single or Dual Cable, and Tall CMK



NOTE: Images are not to scale. Measurements appear in metric units (mm) followed by imperial equivalents (inches).

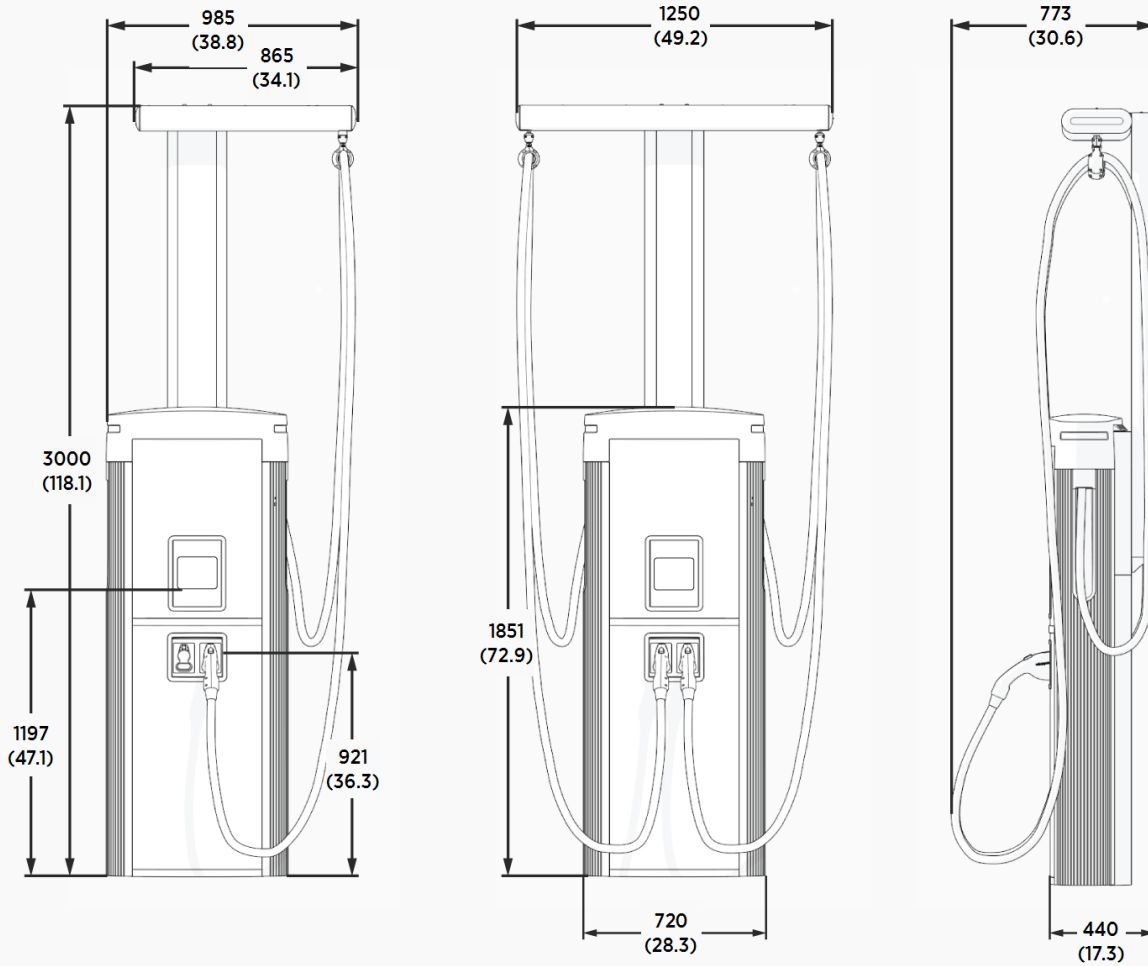

Pedestal-Mount Power Link 2000 With Non-LCC, Single or Dual Cable, and Overhead CMK



NOTE: Images are not to scale. Measurements appear in metric units (mm) followed by imperial equivalents (inches).

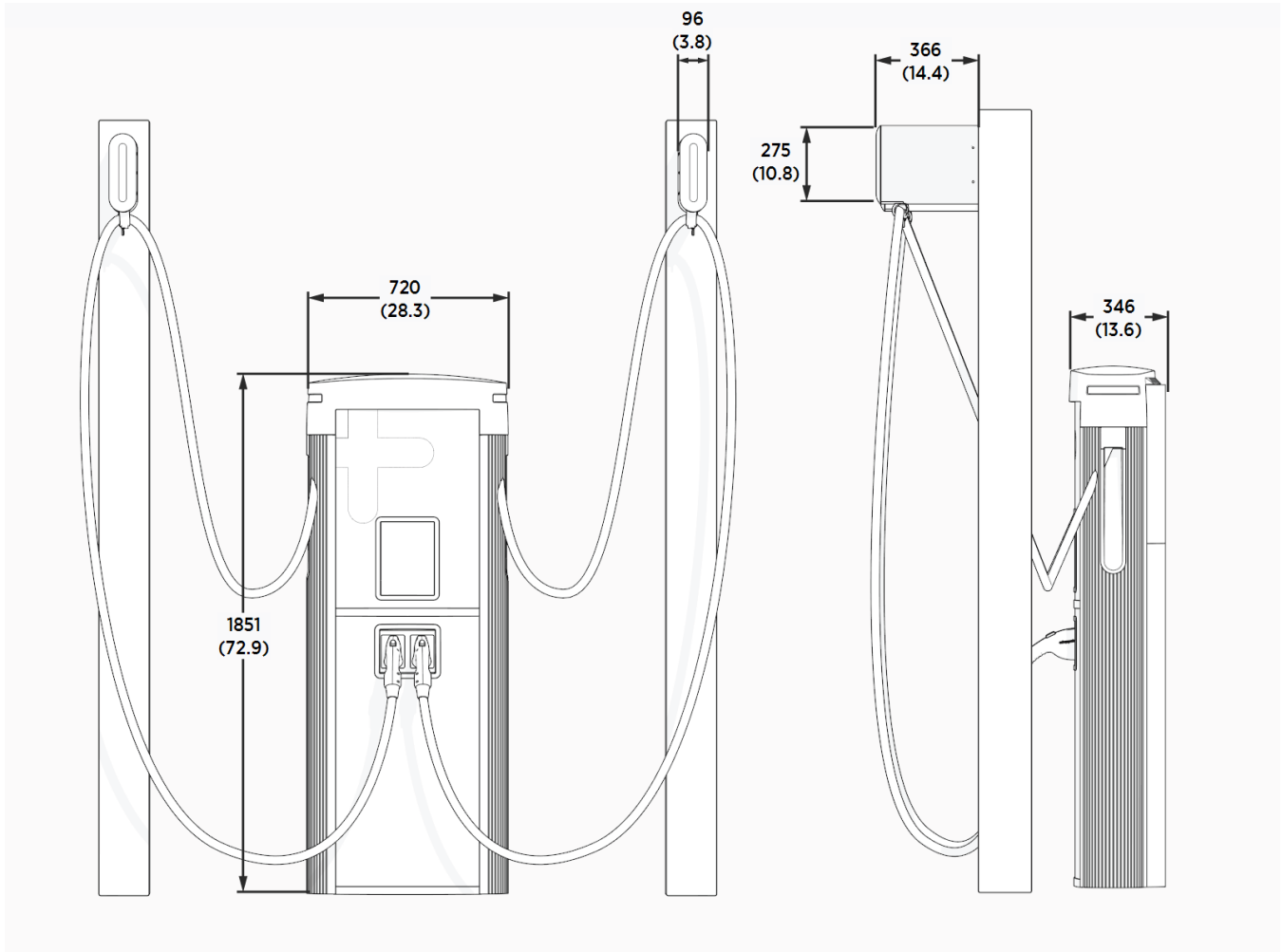

NOTE: The customer must provide the poles at the site for installing pedestal-mount (single or dual cable) Power Link 2000 enclosures with overhead CMK and tether ball extension. These are not provided by ChargePoint.

Wall-Mount Power Link 2000 With Single or Dual Cable and Standard CMK



NOTE: Images are not to scale. Measurements appear in metric units (mm) followed by imperial equivalents (inches).

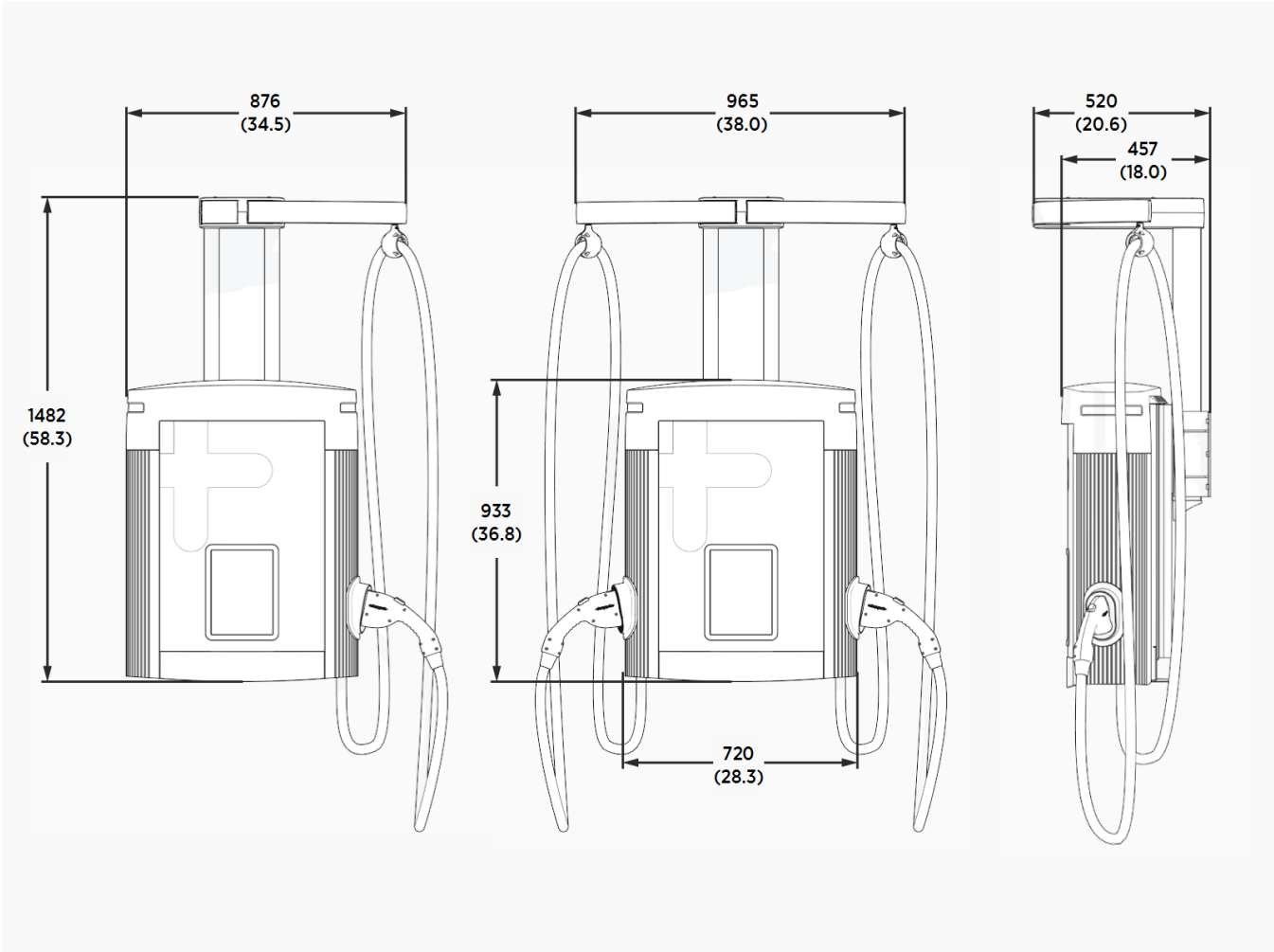

Wall-Mount Power Link 2000 With Single or Dual Cable and Tall CMK



NOTE: Images are not to scale. Measurements appear in metric units (mm) followed by imperial equivalents (inches).

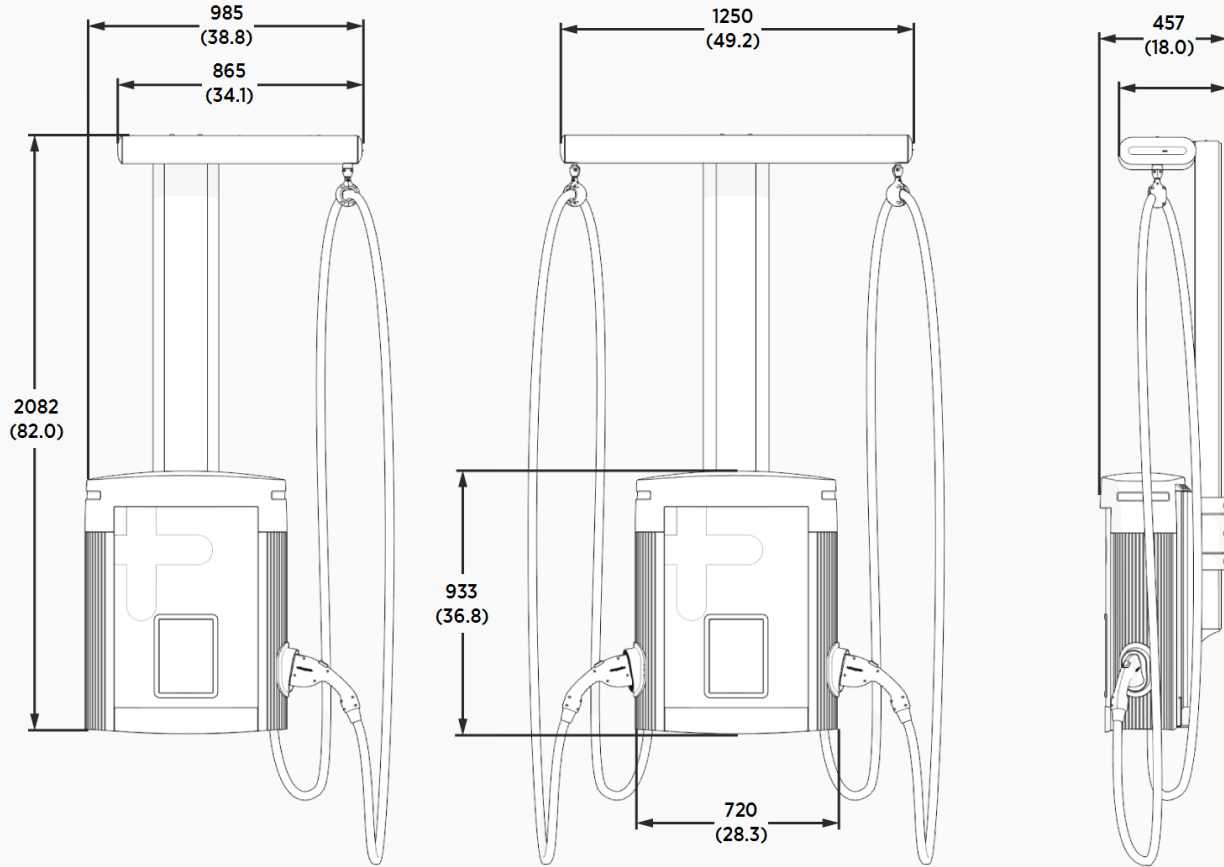

Overhead-Mount Power Link 2000 With Single or Dual Cable and Overhead CMK

The CMK might not fully retract certain charging cables due to their heavier weight. Adding a tether point and a tether hook kit reduces cable weight on the CMK, allowing the cable to retract fully.



NOTE: Images are not to scale. Measurements appear in metric units (mm) followed by imperial equivalents (inches).

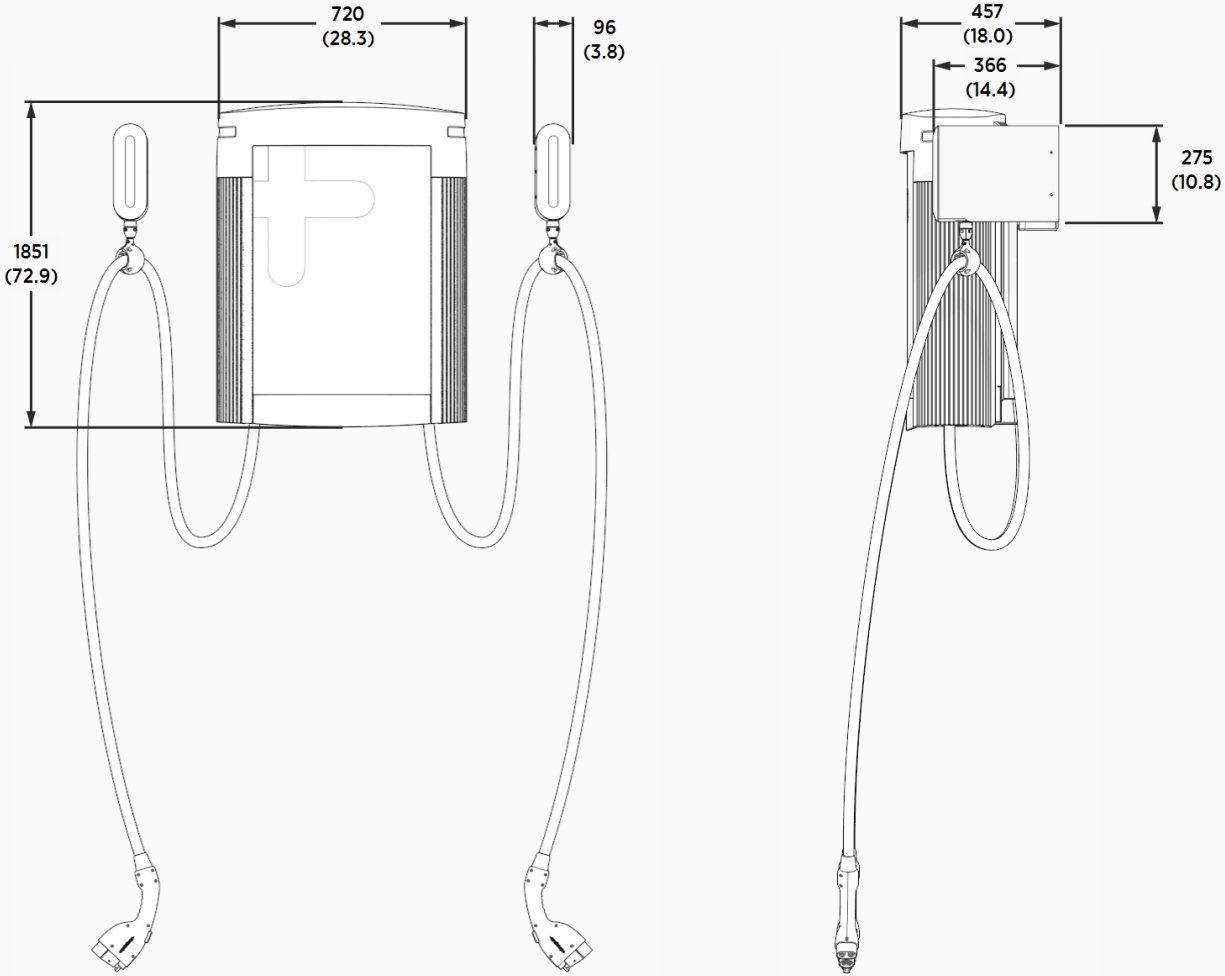

Overhead-Mount Power Link 2000 With Tether Hook



NOTE: Images are not to scale. Measurements appear in metric units (mm) followed by imperial equivalents (inches).

Use tether hooks as additional support for overhead CMKs or to enable the use of third party hoist or cable management solutions.

The tether hook (a) can be attached to either a fixed point or to an alternate cable management mechanism (b) such as a winch.

In the following image, the charge cable is held with a fixed tether hook (a) and a tool balancer (b). Adjust the tether hook or tool balancer location as necessary for site requirements.



NOTE: Images are not to scale. Measurements appear in metric units (mm) followed by imperial equivalents (inches).

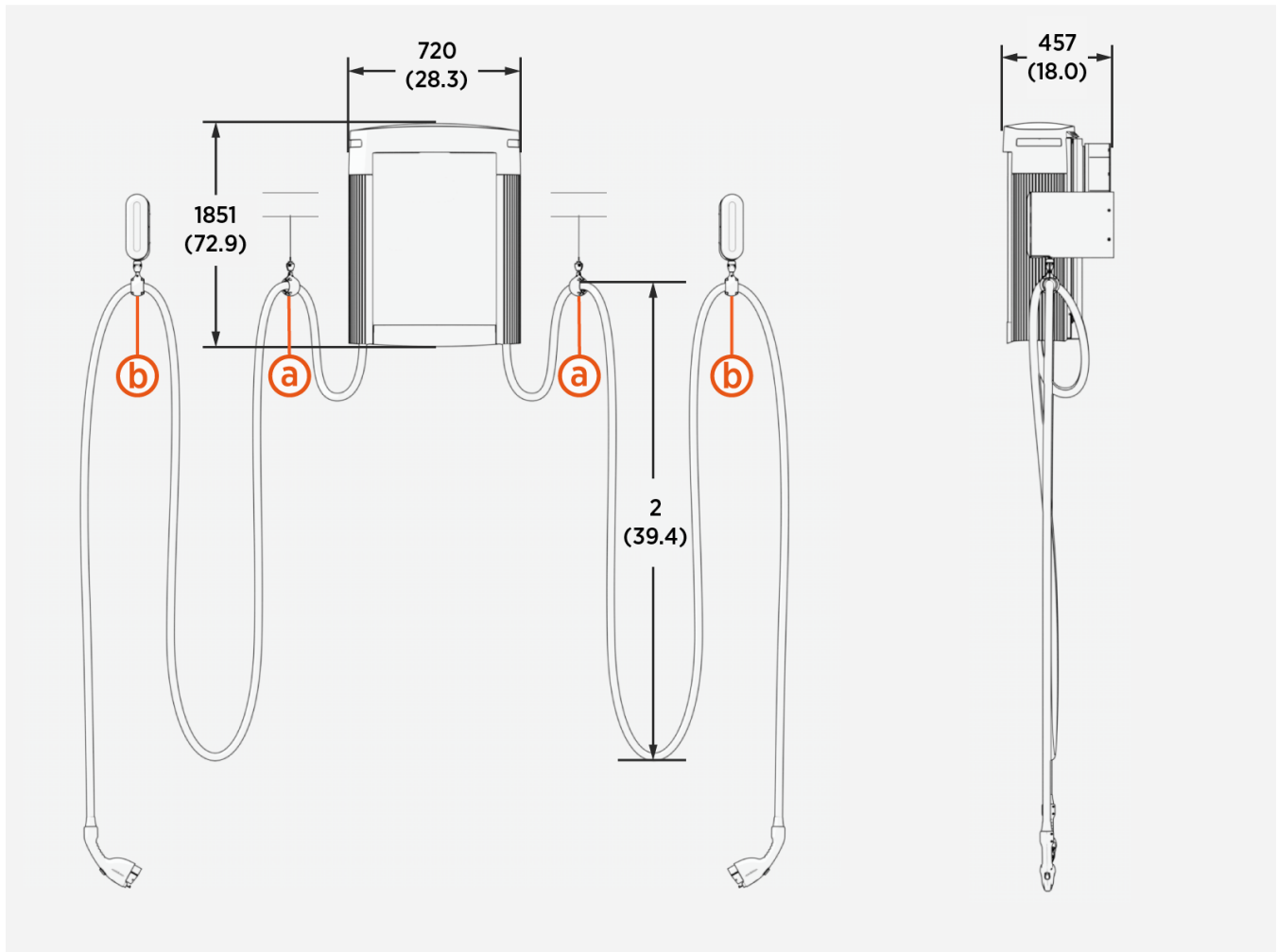

Tether hook dimensions are given in the following image.



NOTE: Images are not to scale. Measurements appear in metric units (mm) followed by imperial equivalents (inches).

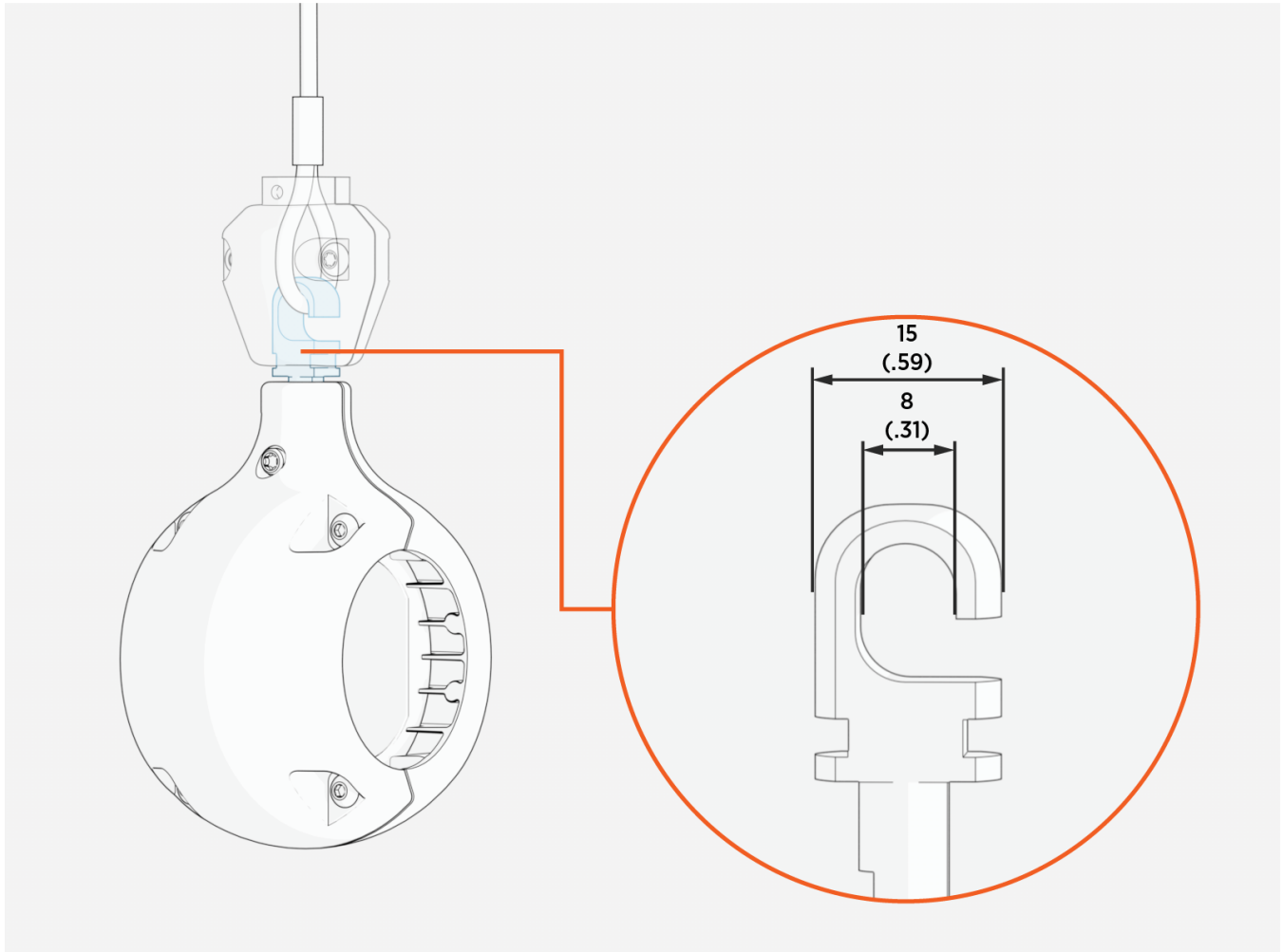

Pedestal-Mount Specifications

The Power Block and pedestal-mount Power Link 2000 must be installed on either a newly poured concrete pad embedded with the Concrete Mounting Template (CMT) or on an existing concrete surface using the Surface Conduit Entry (SCE) kit.

Another option available through a third party is precast concrete blocks. For more details, contact ChargePoint.



IMPORTANT: Stub-up entry of wires laid underground is the most common installation method. Surface entry of wires laid above ground is allowed only at sites where the wires cannot be laid underground such as in a parking garage. Contact ChargePoint for the Surface Conduit Entry (SCE) kit, which includes the hardware needed to install on an existing concrete surface.



WARNING: If not installed correctly, the ChargePoint charging station may pose a crushing hazard, leading to death, personal injury, or property damage. Always use the Concrete Mounting Template specified in this document section, or a ChargePoint-approved surface mounting solution, to install the ChargePoint charging station. Always install in accordance with applicable codes and standards using licensed professionals. Non-approved installation methods are performed at the risk of the contractor and void the Limited One-Year Parts Exchange Warranty.

Concrete Pad Specifications



IMPORTANT: The concrete surface must be smooth and cannot exceed a slope of 20 mm per meter (1/4 inch per foot). If an existing concrete surface does not meet the slope requirement, a localized concrete pad must be poured and leveled to meet the slope requirement.

The concrete pad for the Power Block and Power Link 2000 must either be designed to be site-specific or must meet the specifications provided below. In some extreme conditions, a larger pad may be required. For sites with less stringent seismic, soil, or wind conditions, a smaller pad might be possible.

Conservative stability specifications for the Power Block and Power Link 2000 are listed below for the following design scenarios:

1. 170 mph wind, high seismic, Class 3 Soil
2. 170 mph wind, high seismic, Class 4 Soil
3. 170 mph wind, high seismic, Class 5 Soil
4. 140 mph wind, lower seismic, Class 3 Soil
5. 140 mph wind, lower seismic, Class 4 Soil
6. 140 mph wind, lower seismic, Class 5 Soil

All scenarios assume:

- Minimum concrete rating of 2500 PSI.
- All-threaded M16 anchor bolts are embedded 229 mm (9 in) into the concrete pad and are made of ASTM F1554 Grade 55 carbon steel and hot dip galvanized (HDG).
- The anchor bolts placement is centered within the designed stability area.

Power Block

Design Scenarios	Pad Width		Pad Thickness	#N1 @ S1" O.C. Top Rebar	#N2 @ S2" O.C. Bottom Rebar
1	1753 mm (69 in)	1753 mm (69 in)	457 mm (18 in)	#4 @ 305 mm (12 in) O.C.	#4 @ 305 mm (12 in) O.C.
2	1753 mm (69 in)	1753 mm (69 in)	686 mm (27 in)	#4 @ 152 mm (6 in) O.C.	#4 @ 152 mm (6 in) O.C.
3	1524 mm (60 in)	1524 mm (60 in)	457 mm (18 in)	#4 @ 305 mm (12 in) O.C.	#4 @ 305 mm (12 in) O.C.
4	1524 mm (60 in)	1524 mm (60 in)	457 mm (18 in)	#4 @ 305 mm (12 in) O.C.	#4 @ 305 mm (12 in) O.C.
5	1524 mm (60 in)	1524 mm (60 in)	457 mm (18 in)	#4 @ 305 mm (12 in) O.C.	#4 @ 305 mm (12 in) O.C.
6	1524 mm (60 in)	1524 mm (60 in)	457 mm (18 in)	#4 @ 305 mm (12 in) O.C.	#4 @ 305 mm (12 in) O.C.

Power Link 2000

Design Scenarios	Pad Width		Pad Thickness	#N1 @ S1" O.C. Top Rebar	#N2 @ S2" O.C. Bottom Rebar
1	1499 mm (59 in)	1499 mm (59 in)	432 mm (17 in)	#4 @ 305 mm (12 in) O.C.	#4 @ 305 mm (12 in) O.C.
2	1499 mm (59 in)	1499 mm (59 in)	610 mm (24 in)	#5 @ 305 mm (12 in) O.C.	#5 @ 305 mm (12 in) O.C.
3	1499 mm (59 in)	1499 mm (59 in)	610 mm (24 in)	#5 @ 305 mm (12 in) O.C.	#5 @ 305 mm (12 in) O.C.
4	1219 mm (48 in)	1219 mm (48 in)	330 mm (13 in)	#4 @ 305 mm (12 in) O.C.	#4 @ 305 mm (12 in) O.C.
5	1219 mm (48 in)	1219 mm (48 in)	483 mm (19 in)	#5 @ 305 mm (12 in) O.C.	#5 @ 305 mm (12 in) O.C.
6	1219 mm (48 in)	1219 mm (48 in)	483 mm (19 in)	#5 @ 305 mm (12 in) O.C.	#5 @ 305 mm (12 in) O.C.

In the case of using an existing pad, the pad must either meet one of the above specifications or it must be inspected and approved by a structural engineer for the specifications given below:

Specification	Power Block	Power Link 2000
Weight	680 kg (1500 lb)	See Weights
Height x width	2191 mm (86.3 in) x 1000 mm (39.4 in)	See Dimensions
Frontal area	Height * width	Height * width
CG height	1000 mm (39.4 in)	1524 mm (60 in)
Anchor bolts size and quantity	M16 (x4)	
Anchor bolts embedment	229 mm (9 in)	
Anchor bolts placement	See Anchor Bolts Placement	

Anchor Bolts Placement

The Power Block and Power Link 2000 enclosures mount over four anchor bolts embedded in the concrete pad. The anchor bolt patterns are shown below.



NOTE: Images are not to scale. Measurements appear in metric units (mm) followed by imperial equivalents (inches).

Power Block

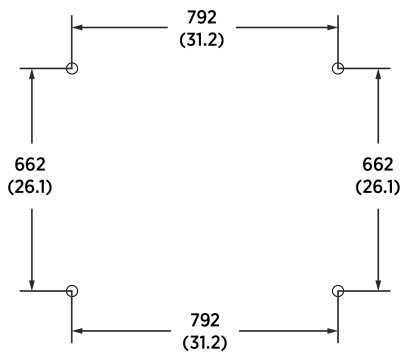

Power Link 2000

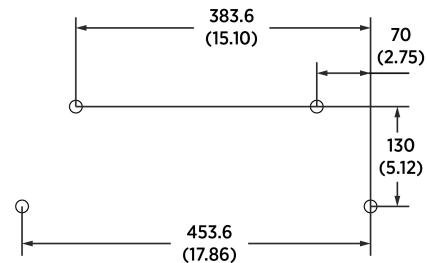

Wires Entry - Stub-up

The most common mounting method for the Power Block and Power Link 2000 is new pad installation using a Concrete Mount Template (CMT) with stub-up wire entry.

- The Power Block and Power Link 2000 pedestals must each mount onto four M16 anchor bolts exposed 76 mm (3 in) above the concrete pad.

The Concrete Mounting Template (CMT) of Power Block and Power Link 2000 is embedded into a newly poured concrete pad to align anchor bolts and underground run stub-up wiring conduits or armored cables.



NOTE: The CMT of Power Block and Power Link 2000 are shipped separately and they must be assembled onsite before pouring the concrete pad (refer to the Concrete Mounting Template Guide for more information).

- In regions that use conduits, the conduits must not have bell ends. Conduits with bell ends may interfere with tolerances inside the Power Block and Power Link 2000.
- Conduits must have stub-ups to the following height from the concrete pad surface:
 - Power Block: 559–914 mm (22–36 in)
 - Power Link 2000: 102–160 mm (4–6.25 in)

Power Block Concrete Mounting Template (CMT)

The Power Block CMT positions the anchor bolts and wire conduits as shown below.

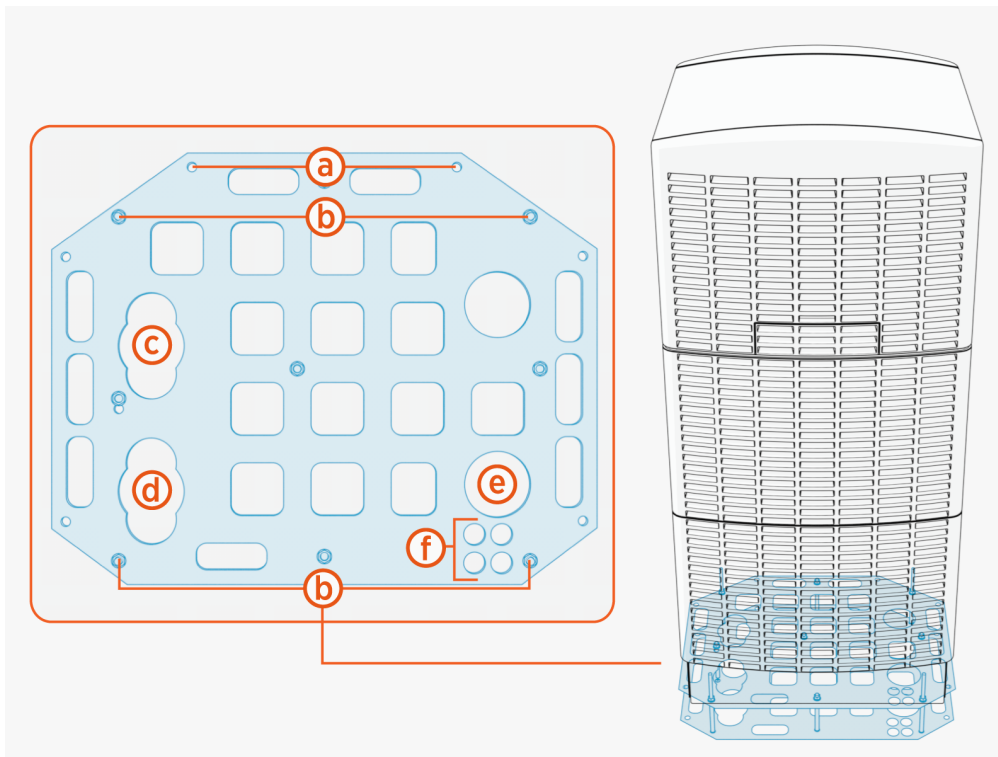

- (a)** M16 anchor bolt (x2) locations for mounting SCE gland plate (applicable only for surface entry of wires).
- (b)** M16 anchor bolt (x4) locations 76 mm (3 in) above concrete for mounting Power Block.
- (c)** HV DC output B wires exit.

(d) HV DC output A wires exit.



NOTE: The DC output of Power Block is the DC input for Power Link 2000.

(e) AC input wires entry.

(f) LV DC output, shunt trip wires, and Ethernet cable exit.

- One for shunt trip (if used).
- Three for LV wires and Ethernet cable.



IMPORTANT: In regions that use conduits, the conduits must be laid per the conduit layout defined by the Concrete Mounting Template (CMT) and the outer diameter of conduits must not exceed the trade sizes listed below. In regions that do not use conduits and/or use armored cables, the cables may be laid per the conduit layout defined by the CMT.

The CMT must be embedded with its top panel positioned 51 mm (2 in) below the concrete surface.

The following table provides the maximum size and quantity of conduits that can be installed on Power Block:

Conduits For	Conduit Quantity x Trade Size	
	North America	Europe
HV DC output wires	2 x 4 inch max. or 4 x 3 inch max.	2 x 110 mm max. or 4 x 78 mm max.
AC input wires	1 x 4 inch max.	1 x 110 mm max.
LV DC, shunt trip, and Ethernet output wires	4 x 1 inch max.	4 x 25 mm max.



IMPORTANT:

- The actual conduit size and quantity must be chosen based on site-specific wiring requirements. The maximum conduit sizes listed are based on maximum quantity the Power Link 2000 can accommodate.
- For wire specifications, see [Wiring Requirements](#).

Power Link 2000 Concrete Mounting Template (CMT)

The Power Link 2000 CMT positions the anchor bolts and wire conduits as shown below.

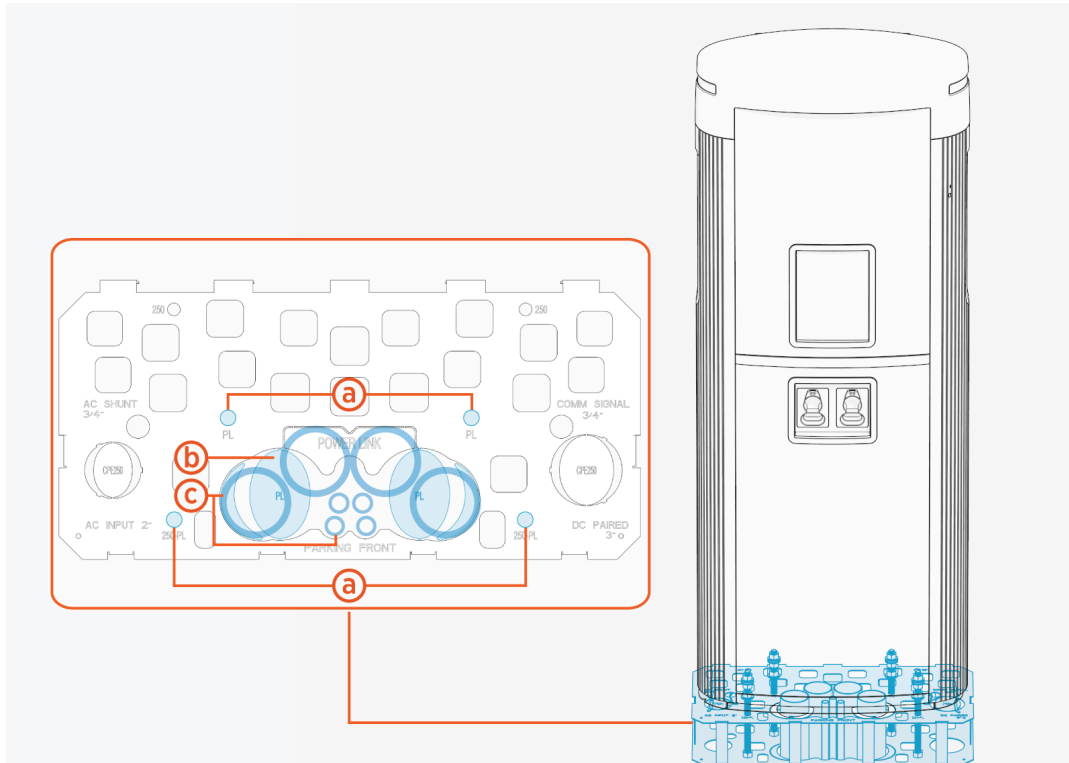

- (a) M16 anchor bolt (x4) locations for mounting Power Link 2000 (see [Anchor Bolts Placement](#))
- (b) Breakaway tabs for entry of wires through conduits (c) or armored cables.



IMPORTANT: In regions that use conduits, the conduits must be laid per the conduit layout specified by the Concrete Mounting Template (CMT) and the outer diameter of conduits must not exceed the trade sizes listed below. If the conduits are not used, the cables may be laid per the conduit layout specified by the CMT.

The CMT must be embedded with its top panel positioned 51 mm (2 in) below the concrete surface.

The following table provides the maximum size and quantity of conduits that can be installed on Power Link 2000 by removing the breakaway tabs:

Conduits For	Conduit Quantity x Trade Size	
	North America	Europe
HV DC wires	2 x 4 inch max. or 4 x 3 inch max. or 6 x 2 inch max.	2 x 103 mm max. or 4 x 78 mm max. or 6 x 53 mm max
LV DC wires and Ethernet cable	2 x 1 inch(*)	2 x 27 mm(**)
Optional features (Ethernet to USB or soft shutdown switch)	2 x 3/4 inch max.	2 x 21 mm max.



NOTE: (*) In North America, 1 inch size conduit is required for LV DC input wires and Ethernet cables. The quantity of conduit will depend on the configuration. (**) In Europe, 27 mm size conduit is required for LV DC input wires and Ethernet cables. The quantity of conduit will depend on the configuration.



IMPORTANT:

- The actual conduit size and quantity must be chosen based on site-specific wiring requirements. The maximum conduit sizes listed are based on maximum quantity the Power Link 2000 can accommodate.
- For wire specifications, see [Wiring Requirements](#).

Surface Mount

The Power Block and Power Link 2000 may be installed on an existing concrete surface in accordance with the following guidelines:

- The concrete surface must be inspected and approved by a structural engineer as described in [Concrete Pad Specifications](#).

- The anchor bolts must be installed in the concrete surface as follows:
 - Anchor holes are drilled into the concrete using the anchor bolt pattern given in [Anchor Bolts Placement](#). The holes are drilled to a depth so that 76 mm (3 in) of each anchor bolt is exposed above the concrete pad.
 - Anchor bolts are epoxied into the holes. Use an epoxy with a minimum bonding strength of 11.7 MPa, compressive strength of 82.7 MPa minimum, and tensile strength of 49.3 MPa minimum. For example, Hilti HIT-RE 500 V3 (normal cure) or Hilti HIT-HY 200-A (fast cure).



NOTE: Different epoxy types have different cure times at various temperatures. Check local temperatures for the site in advance to help choose an appropriate epoxy.

- Use the provided hot-dip galvanized M16 anchor bolts.
- Wires must enter the enclosures using [Surface Wire Entry](#).



NOTE: Power Blocks and Power Link 2000s in a Multiplex architecture cannot be installed on an existing concrete surface because they require stub-up wire entry.

Wires Entry - Surface

Power Block and Power Link 2000 support wiring that is run above ground in protected wireways for locations where no underground wiring access exists (parking garages, etc.) or where underground junction boxes are not permitted.



NOTE: Power Blocks and Power Link 2000s in a multiplex architecture do not support wiring that is run above ground.

If wires or cables are run above ground:

- They must be housed in wireways that conform to local code.
- Ensure the plans for the concrete pad and access area allow full service access to all components. Surface wires entry might require larger clearance areas than embedded installations. A minimum of 610 mm (2 ft) clearance at rear side is required.
- Use flexible wires and conduits, or armored cables.
- Use LB conduit bodies to route wires into Power Link 2000 from rear left or rear right, and they must fit within the rear clearance of 610 mm or 2 ft.
- Use suitable conduit fittings to secure and seal the conduits and/or conduit bodies.
- Prepare the concrete surface where the components will be anchored so that the concrete surface is solid, smooth, and level with no old hardware or stub-ups extending above ground.

Surface wires must enter the Power Block and the pedestal-mount Power Link 2000 using a SCE kit. These kits offer the following benefits:

- Support of the weight of conduits or armored cables without compromising cover panel integrity
- Ensure all terminations meet ingress requirements where they meet the component
- Ensure no obstructions to ventilation, which is required during operation



NOTE: The SCE kit is used for surface wire entry for only the Power Block and pedestal-mount Power Link 2000. It can not be used with a wall or overhead-mount Power Link 2000.

Power Block Surface Conduit Entry (SCE)

Surface-run wires must enter Power Block from the rear side through conduits or armored cables. The Power Block kit provides a sturdy pedestal cover panel onto which surface conduits may be fastened at the rear side of the Power Block.

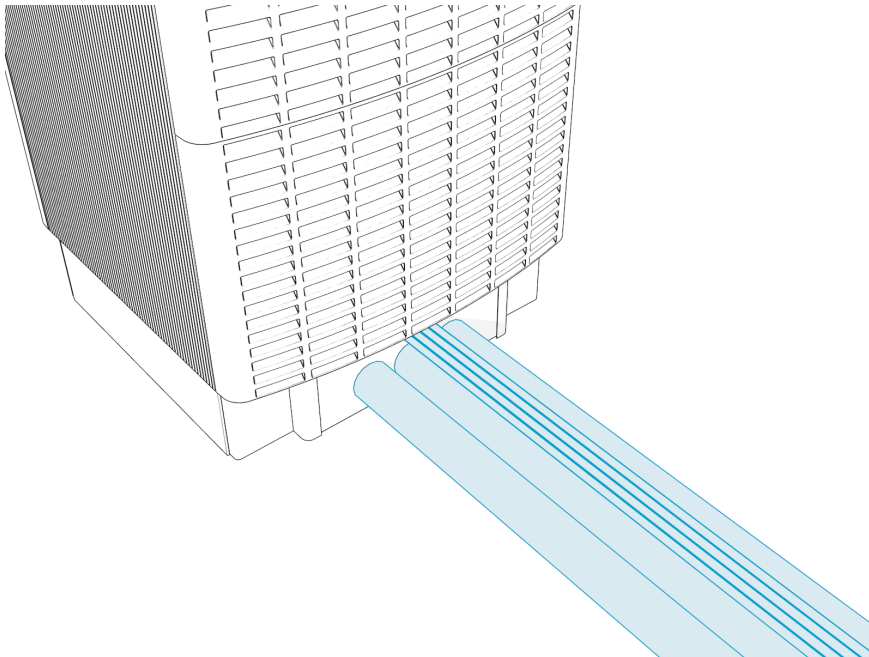

The following table provides the maximum size and quantity of conduits that can be installed on Power Block using the Power Block SCE kit:

Conduits For	Conduit Quantity x Trade Size	
	North America	Europe
AC input wires	1 x 4 inch max.	1 x 110 mm max.
HV DC output wires	2 x 4 inch max.	2 x 110 mm max.
LV DC, shunt trip, and Ethernet output wires	4 x 1 inch max.	4 x 25 mm max.

IMPORTANT:

- The actual conduit size and quantity must be chosen based on site-specific wiring requirements.
- For wire specifications, see [Wiring Requirements](#).

For more information, refer to the *Power Block and Power Link 2000 Surface Conduit Entry Kit Guide*.

Pedestal-Mount Power Link 2000 Surface Conduit Entry (SCE)

The surface-run wires must enter the pedestal-mount Power Link 2000 from the rear side through conduits or armored cables. The Power Link 2000 kit provides a sturdy pedestal cover panel onto which surface conduits may be fastened at the rear side of the Power Link 2000.

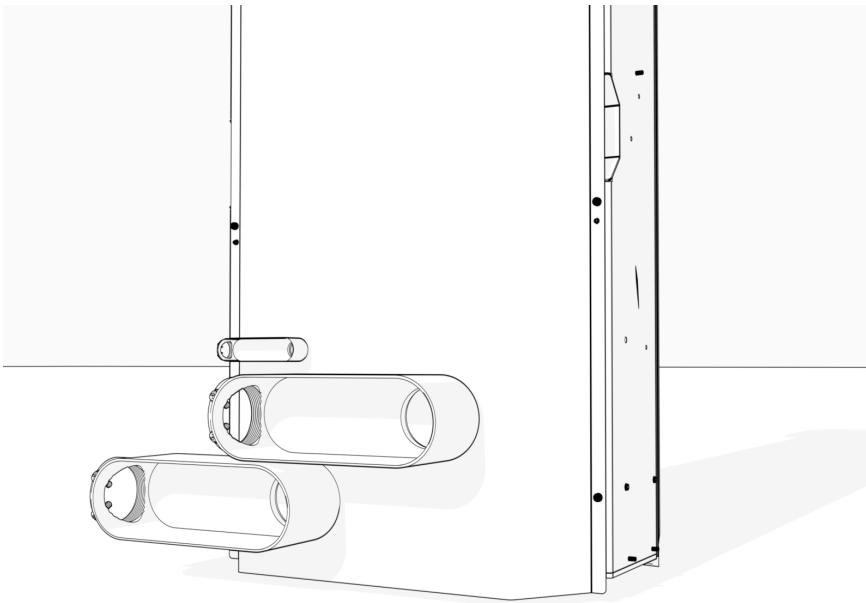

The following table provides the maximum size and quantity of conduits that can be installed on using the SCE kit:

Conduits For	Conduit Quantity x Trade Size	
	North America	Europe
HV DC wires	2 x 3 inch max.	2 x 78 mm max.
LV DC input wires and Ethernet cable	2 x 1 inch(*)	2 x 27 mm(**)
Optional features (Ethernet to USB or soft shutdown switch)	2 x 3/4 inch max.	2 x 21 mm max.



NOTE: (*) In North America, 1 inch size conduit is required for LV DC input wires and Ethernet cables. The quantity of conduit will depend on the configuration. (**) In Europe, 27 mm size conduit is required for LV DC input wires and Ethernet cables. The quantity of conduit will depend on the configuration.



IMPORTANT:

- The actual conduit size and quantity must be chosen based on site-specific wiring requirements.
- For wire specifications, see [Wiring Requirements](#).

For more information, refer to the *Power Block and Power Link 2000 Surface Conduit Entry Kit Guide*.

Cable Management Kit (CMK) Mount Specifications

Standard and Tall CMK

For pedestal-mount and wall-mount Power Link 2000, the standard and tall CMKs mount to the back of Power Link 2000 (see [Dimensions](#) for overall mounting dimensions of Power Link 2000 with standard or tall CMK).

Overhead CMK

If you want to use an overhead CMK with a pedestal-mount Power Link 2000, you must install a pole to mount the overhead CMK next to the Power Link 2000 charging cables.

To mount the overhead CMK for a pedestal-mount Power Link 2000:

- You must design and/or purchase the pole. ChargePoint does not sell and/or supply the pole.
- The pole must have a structural capacity of 1780 N (400 lbf), and it must be designed or verified by a structural engineer per local codes. In the event of a vehicle driveway incident, this structural strength is required to withstand the pull-out force of the vehicle.

- Unless the pole needs to be at a certain location for a specific vehicle inlet, the overhead CMK when mounted onto the pole must have an optimum height of 3 m (10 ft) for maximum cable reach, come at the center of the parking space, and be as far forward as possible aligned with the front of the bollards (see [Bollards](#) for the bollards placement and [Dimensions](#) for the overhead CMK's depth).



NOTE: Images are not to scale. Measurements appear in metric units (m) followed by imperial equivalents (ft).

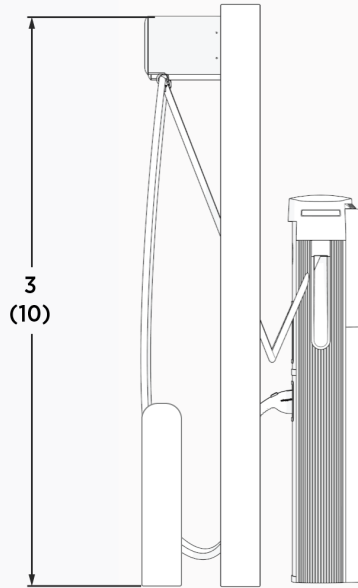

- The overhead CMK must be mounted using its bracket (supplied by ChargePoint) that attaches to its back. The bracket has four holes sized for M8 bolts to mount the overhead CMK onto the pole.



NOTE: The installer must provide the M8 bolts. These are not provided by ChargePoint.



NOTE: Images are not to scale. Measurements appear in metric units (mm) followed by imperial equivalents (inches).

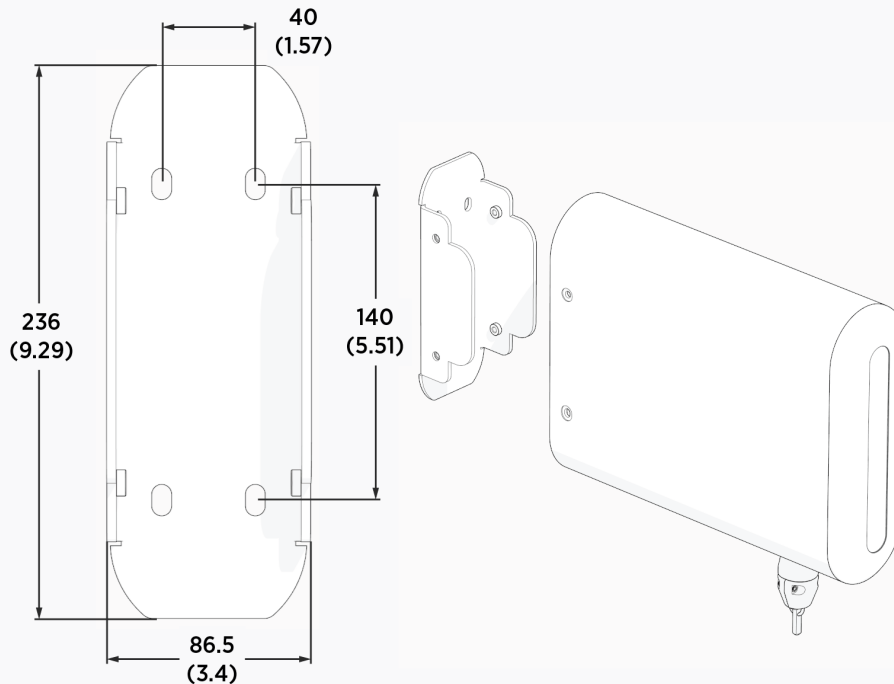

Wall or Overhead-Mount Specifications

The Power Link 2000 mounts onto a wall or an overhead structure (such as a gantry) using a bracket that attaches to its back. The bracket has six mounting holes sized for M8 bolts.



NOTE: Images are not to scale. Measurements appear in metric units (mm) followed by imperial equivalents (inches).

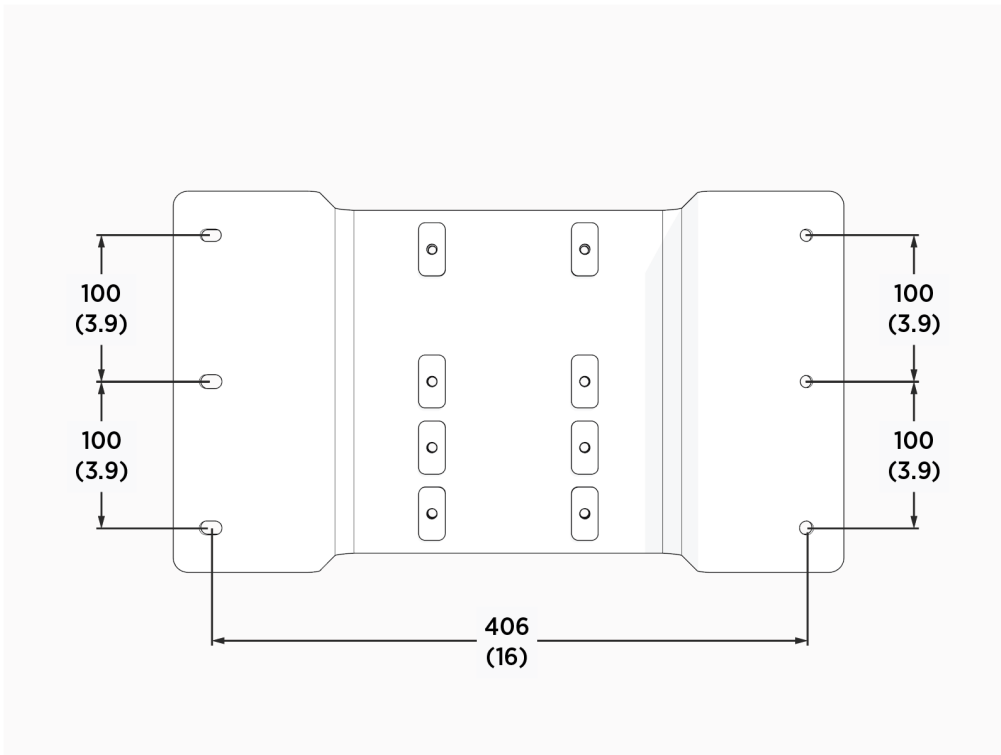
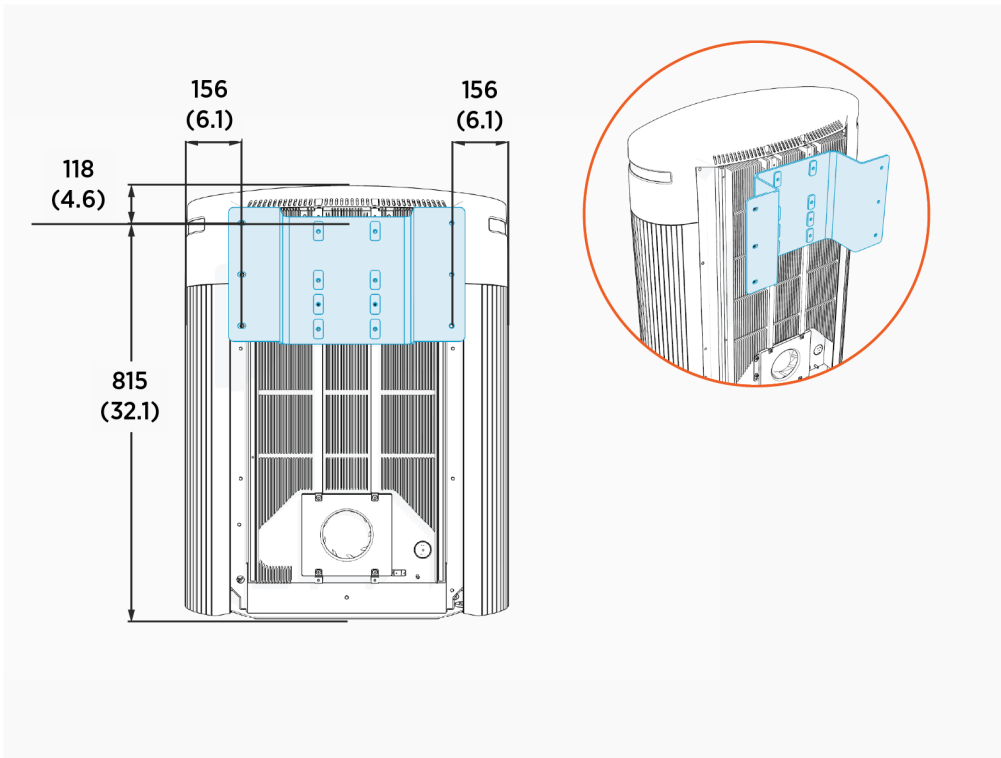

For wall or overhead mounted stations:

- The Power Link 2000 must be mounted upright. Do not mount it in any other orientation.
- The wall must be smooth and plumb.

- The wall or overhead structure must have a structural capacity of 1780 N (400 lbf) in addition to the Power Link 2000 weight. The structure must also be designed or verified by a structural engineer per local codes. In the event of a vehicle drive away incident, this structural strength is required to withstand the pull-out force of the vehicle.

Wires and cables enter wall and overhead-mount Power Link 2000 through its bottom gland plate by conduit or as armored cable. The HV DC wire conduits should attach to the gland plate at locations that align the HV DC wires to their intended power path landings. See [Wire Entry and Landing - Wall and Overhead-Mount Power Link 2000](#)

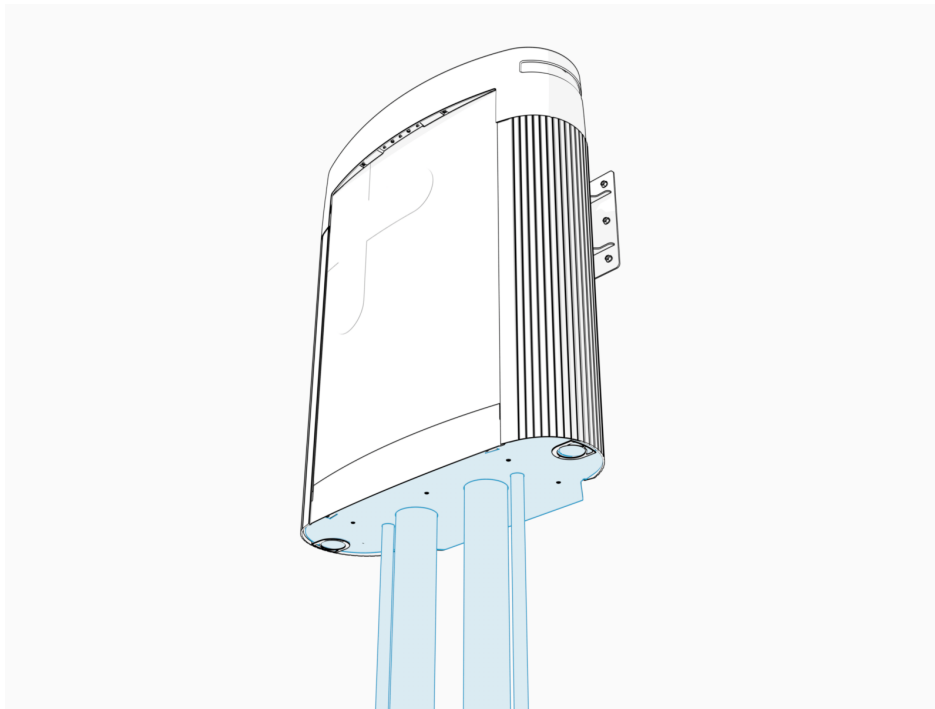

The following table provides the maximum size and quantity of conduits that can be installed on wall or overhead-mount Power Link 2000:

IMPORTANT:



- Actual wire quantity and size must be chosen based on site-specific wiring requirements
- For wire specifications, see [Wiring Requirements](#).

Conduits For	Conduit Quantity x Trade Size	
	North America	Europe
HV DC wires	2 x 4 inch max. or 4 x 3 inch max.	2 x 103 mm max. or 4 x 78 mm max.
LV DC wires and Ethernet cable	2 x 1 inch(*)	2 x 27 mm(**)
Optional features (Ethernet to USB or soft shutdown switch)	2 x 3/4 inch max.	2 x 21 mm max.



NOTE: (*) In North America, 1 inch size conduit is required for LV DC input wires and Ethernet cables. The quantity of conduit will depend on the configuration. (**) In Europe, 27 mm size conduit is required for LV DC input wires and Ethernet cables. The quantity of conduit will depend on the configuration.

For surface run wiring to the wall or overhead-mount Power Link 2000:

- All wires must be housed in wireways that conform to local code.
- Use flexible wires.
- Use suitable conduit fittings to secure and seal the conduits to the enclosure.

Wall and overhead-mount height specifications are given below:

- Wall mount: The height of the mounting bracket is 1733 mm (68.2 in) above a finished floor. If site conditions require, the bracket can be lowered.



NOTE: Images are not to scale. Measurements appear in metric units (mm) followed by imperial equivalents (inches).

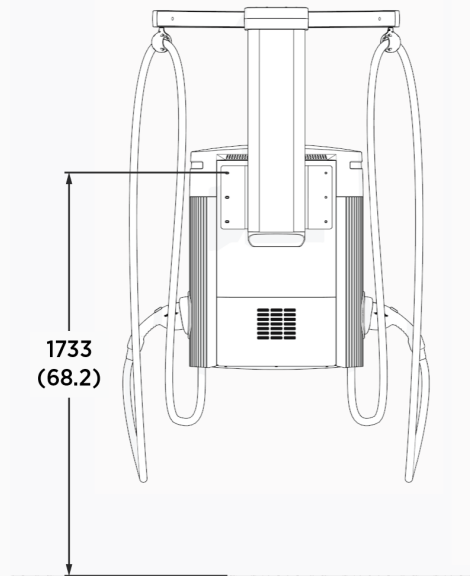

- Overhead mount:



IMPORTANT: The height for overhead mount must be calculated based on site specific requirements. For assistance, [contact ChargePoint](#).

- For maximum cable reach :
 - Mount the Power Link 2000 at a height of 6096 mm (240 in) above the finished floor.



NOTE: The mounting height can be adjusted based on site needs.

- Mount the overhead CMK bracket in-line and 203 mm (8 in) away from the Power Link 2000 bracket.



NOTE: Images are not to scale. Measurements appear in metric units (mm) followed by imperial equivalents (inches).

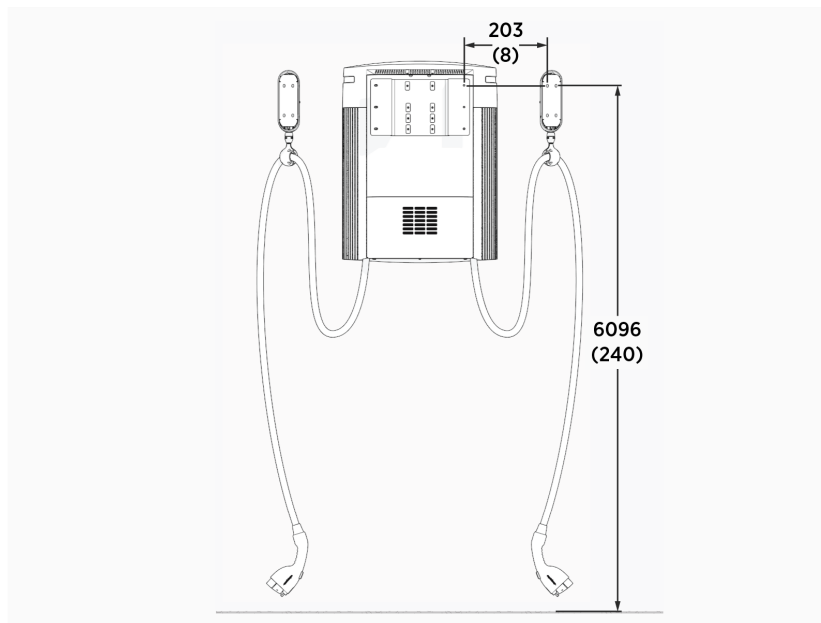

- The overhead CMK bracket must be mounted a minimum of 203 mm (8 in) away from the outer sides of the Power Link 2000 mounting bracket.

- The overhead CMK cable measures 3 m (118 in) when fully extended.



NOTE: Images are not to scale. Measurements appear in metric units (m) followed by imperial equivalents (inches).

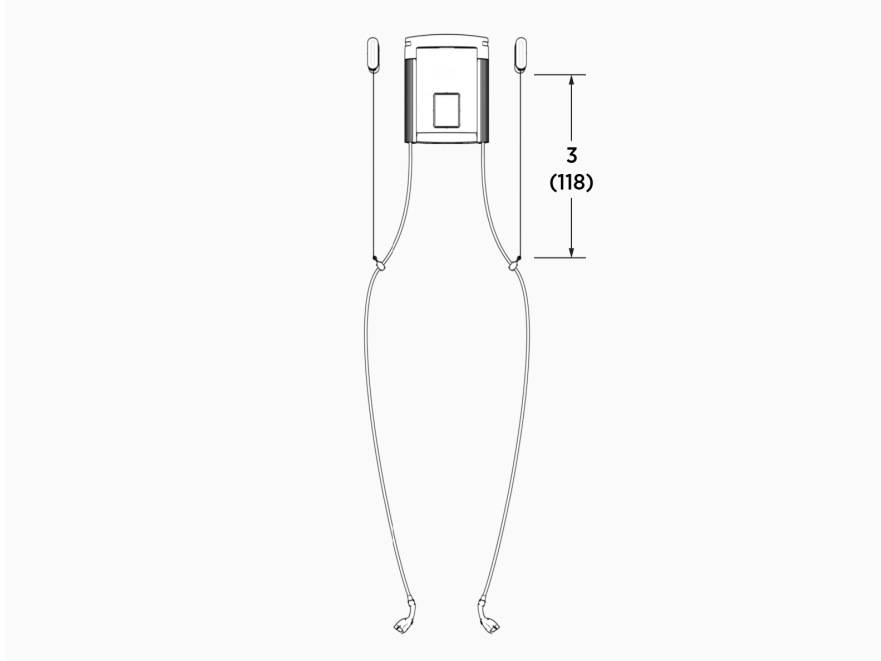

Drainage

Ensure any site slopes, walls, or fencing do not trap water around the installation site.

Flood Plane

Power Block is designed with a 457 mm (18 in) flood plane. If site conditions show a higher than 457 mm (18 in) flood plane for a 100-year flood event, consider installing the Power Block on a raised concrete pad.



WARNING: Exposing the Power Block to over 457 mm (18 in) of standing water could create an electrocution, shock, or fire hazard.

If the Power Block has been exposed to standing water exceeding this threshold, cut power to the Power Block and contact ChargePoint before powering on the Power Block.

Clearances

Clearance requirements for Power Block and Power Link 2000 are given below.

Power Block

Two Power Blocks laid side-to-side

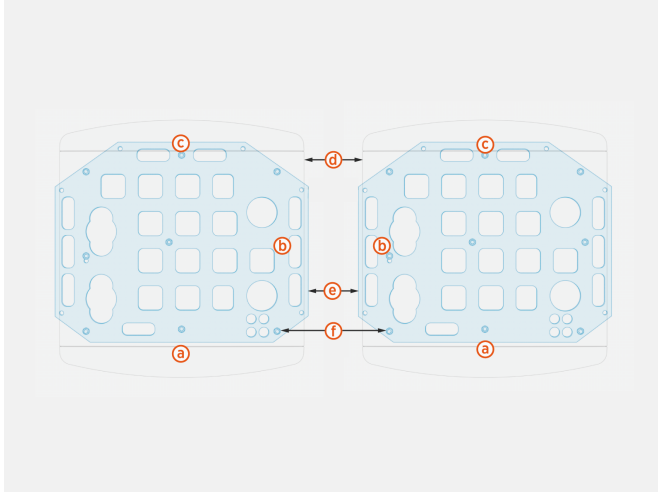

Two Power Blocks laid back-to-back

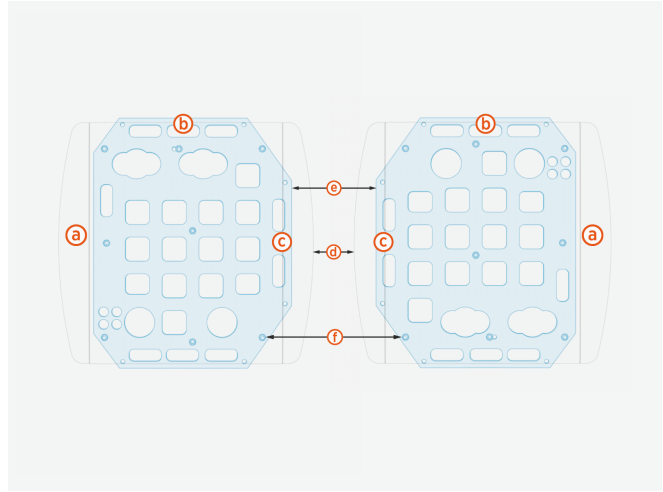

The following table provides the clearances required for service and ventilation around the Power Block (PB):

Side	Power Blocks Layout	Clearance		
(a) Front	—	—	Minimum 1000 mm (39.4 in)	
(b) Sides	PBs laid side-to-side	Minimum	(d) PB to PB	51 mm (2 in)
			(f) Center of anchor bolt to center of anchor bolt	245 mm (9.6 in)
		Recommended	(d) PB to PB	152 - 203 mm (6 - 8 in)
			(e) CMT to CMT	116 - 167 mm (3.4 - 5.4 in)
(c) Rear	PBs laid back-to-back	(d) PB to PB	457 - 609 mm (18 - 24 in)	
		(e) CMT to CMT	609 - 761 mm (24 - 30 in)	
		(f) Center of anchor bolt to center of anchor bolt	376 - 427 mm (14.8 - 16.8 in)	



NOTE: If placing two Power Blocks back-to-back using surface conduit entry, there must be at least 609 mm (24 in) of shared rear clearance.

Additionally, follow the clearance guidelines below:

- Front and rear clearances must be at grade level +/- 13 mm (0.5 in).
- The interior of the Power Block is accessed from both the front and rear cover panels, which lift off. No separate door swing clearance is required.
- Fencing, bollards, or wheel stops must not encroach upon the clearances listed above, if present. These barriers are not explicitly required by ChargePoint.
- Power Blocks can be laid side-to-side with minimal spacing for service and ventilation. If laid side-to-side, wiring can enter using either stub-up entry (recommended) or using surface entry at the rear side. When laid side-to-side, wiring for the row cannot pass through one Power Block into another.
- Side clearances can be shared between Power Blocks as long as:
 - At least 51 mm (2 in) of clearance is maintained between each Power Block.
 - Required service clearance is maintained at the front and rear sides.
 - At least 457 mm (18 in) of clearance is available at each end of a row of Power Blocks.



NOTE: For any questions about allowable layouts, [contact ChargePoint](#).



CAUTION: Each Power Module weighs 45 kg (98.5 lbs). At least two people are required to replace a Power Module. The front clearance must be spacious enough to accommodate at least two people.



IMPORTANT: Check local and regional codes for any additional clearance requirements regarding safety, high voltage equipment, and accessibility requirements.

Power Link 2000

The Power Link 2000 requires minimum site and service clearances listed below.

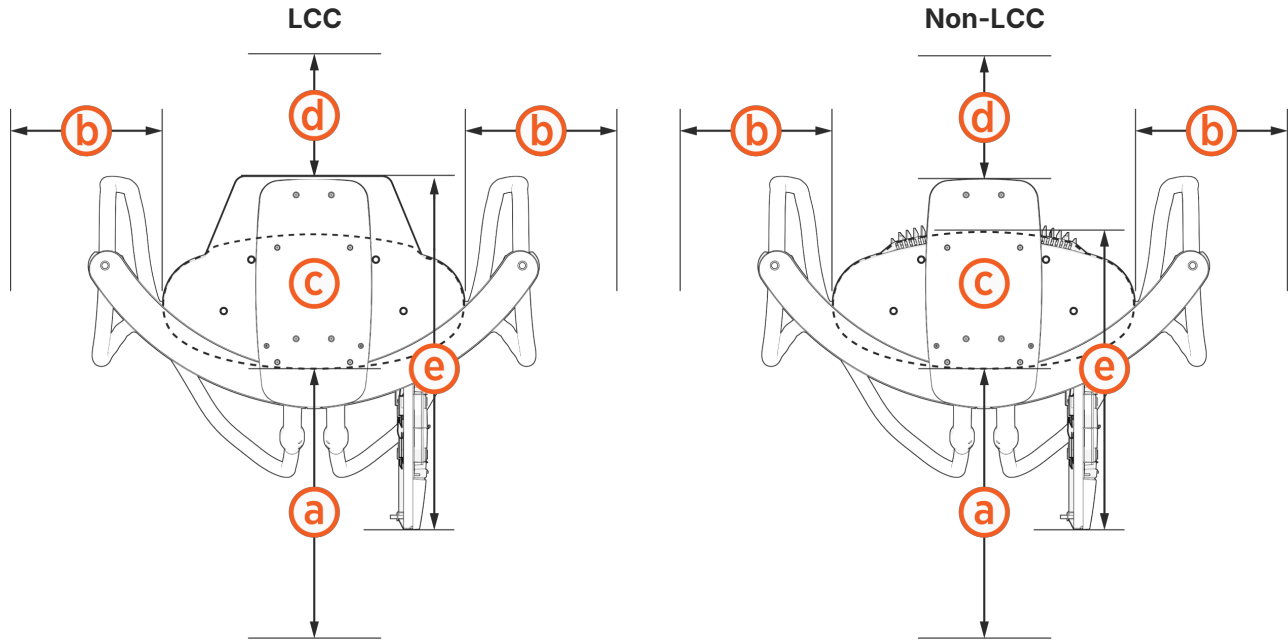

Power Link 2000		Clearance
(a) Front	Minimum open space	610 mm (2 ft)
(b) Side		305 mm (12 in) at grade, minimum NOTE: 610 mm (24 in) recommended for user service and this 610 mm (24 in) can be shared between Power Link 2000s
(c) Top	Pedestal or wall-mount	26 mm (1 in) from top of CMK or 305 mm (12 in) from top of Power Link 2000, whichever is higher.
	Overhead-mount	305 mm (12 in) from top of Power Link 2000
(d) Rear	Pedestal-mount	203 mm (8 in) for non-LCC or 305 mm (12 in) for LCC. This provides service clearance for CMK and LCC. NOTE: At least 610 mm (2 ft) of clearance is required for surface conduit entry. In the case of back-to-back Power Link 2000s, each with surface conduit entry, the clearance can be shared.
(e) Door swing plus station width		730 mm (2 ft 4-3/4 in)

Wheel Stops and Bollards

Bollards and wheel stops are not explicitly required by ChargePoint. However, ChargePoint recommends these best practices and considerations when designing the site:

- Permanent bollards or wheel stops must not encroach upon the clearances listed in the clearance diagrams in this section. Removable bollards are allowed if service personnel have the ability to move them as needed.
- Where permitted by code, wheel stops are preferred over bollards for head-in or back-in spaces.

Wheel Stops

- When using wheel stops, consider the average vehicle overhang distance for the largest type of vehicle (passenger, bus, etc.), as well as leaving space for the driver to walk up and access the station.
- Position wheel stops to actively block at least one wheel, without presenting a trip hazard to pedestrians walking between vehicles.

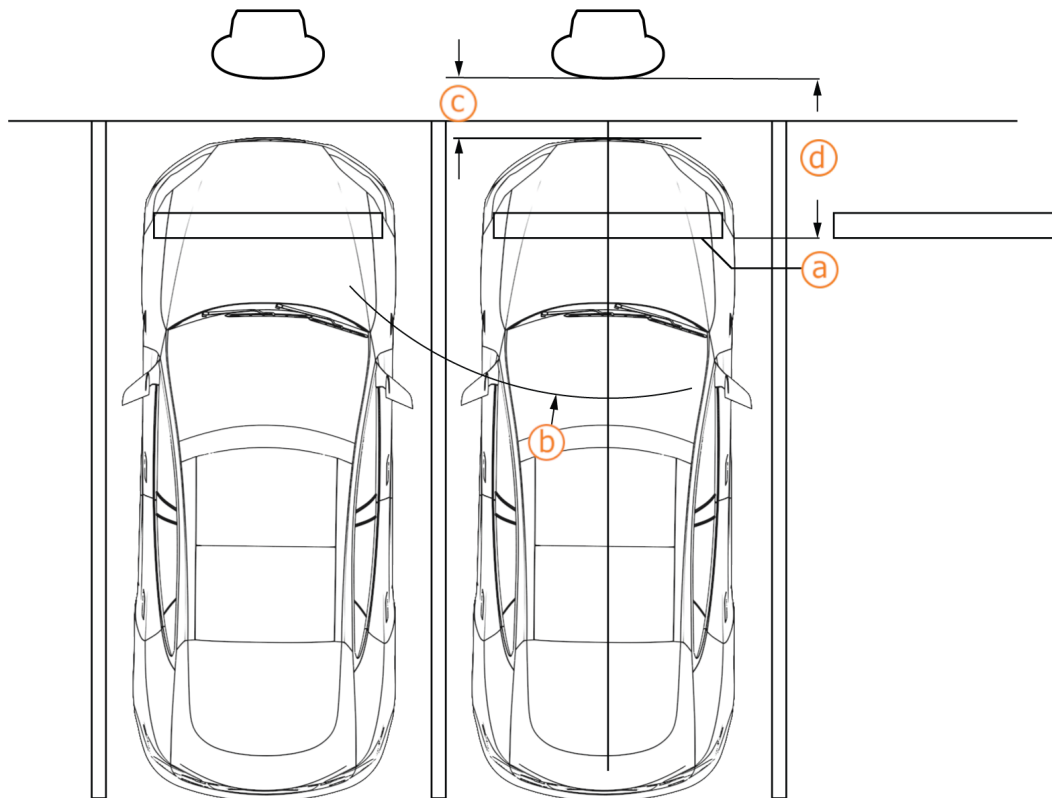

- (a)** Wheel stop, positioned to actively block at least one wheel
- (b)** Cable reach radius: 3.76 m (148 in)
- (c)** Recommended distance for walk-up access: 609 mm (24 in)
- (d)** Recommended distance between wheel stop and station: 1371 mm (54 in) for passenger vehicles

Bollards

- When bollards are required by code, needed for snowy areas, or needed for curbside spaces, ensure bollard placement does not interfere with removing and replacing charge cables in the station's holsters.

- Try to minimize bollard interference with the movement of charge cables between the station and the vehicle. Bollard height is recommended to be no higher than 914 mm (36 in) where needed.
- Follow the measurements listed for bollards placement:
 - (a) Anchor bolt to bollard inside edge: 254 mm (10 in)
 - (b) Anchor bolt to bollard front edge: 424 mm (16.7 in)
 - (c) Power Link 2000 side to bollard inside edge: 122 mm (4.8 in)
 - (d) Power Link 2000 front to bollard front edge: 305 mm (12 in)

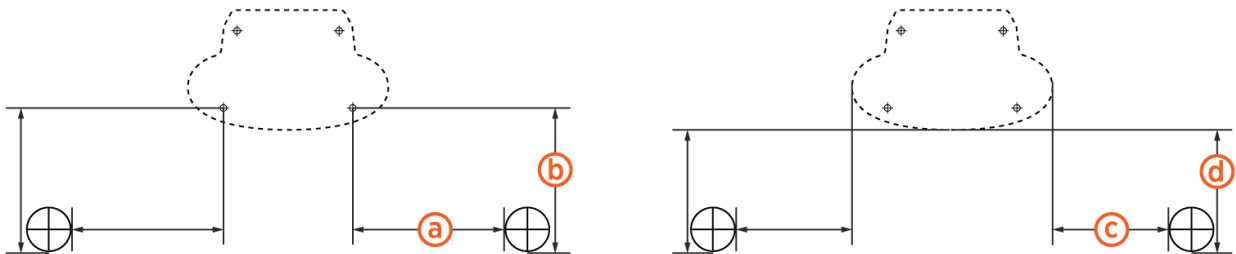

Ventilation

Ventilation requirements for Power Block and Power Link 2000 are given below.

Power Block

Intake vents are positioned at the front of the Power Block (blue arrows) and exhaust vents are at the rear (orange arrows). When positioning multiple Power Blocks, orient intake and exhaust to avoid recirculation.

Power Block requires 10 kW (34,000 BTU/hr) of heat rejection.

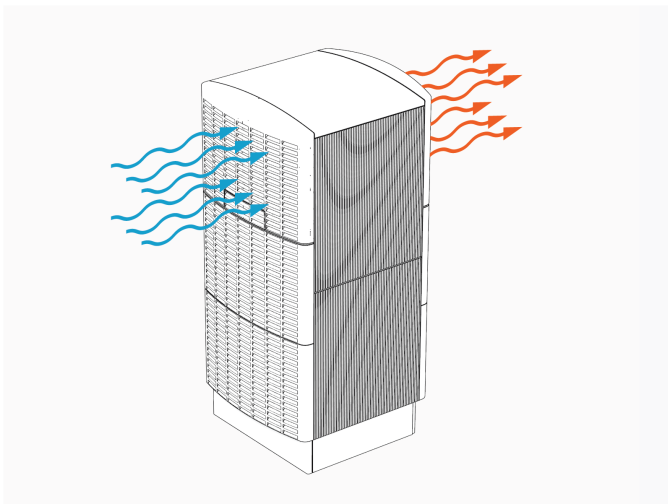

Power Link 2000

Ensure that any installation, especially an indoor installation, has adequate airflow to dissipate heat at maximum operation. The station location must allow fresh ambient airflow and must be free of any objects that might restrict airflow to the station. A station experiencing temperatures in excess of the maximum allowed operating temperature may deliver reduced maximum performance.



NOTE: Power Link 2000s without liquid cooled cables require 500 W (1,700 BTU/hr) of heat rejection. Power Link 2000s with liquid cooled cables require 5.3 kW (18,000 BTU/hr).

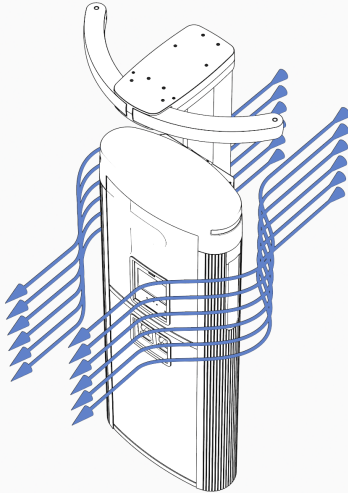

Accessibility

Comply with regional accessibility laws, regulations, and ordinances. The Power Link 2000 charging station must not block ramps or pathways and the height of the interactive display cannot exceed the maximum height as dictated by local laws.

Do not install Power Link 2000 on a raised concrete pad for parking spaces reserved for people with limited mobility. Power Link 2000 meets ADA height requirements when measured from a finished floor or ground plane (i.e., Power Link 2000's all operable parts, such as cable connectors and display, are no higher than 1220 mm or 48 in and no lower than 381 mm or 15 in from a finished floor or ground plane).

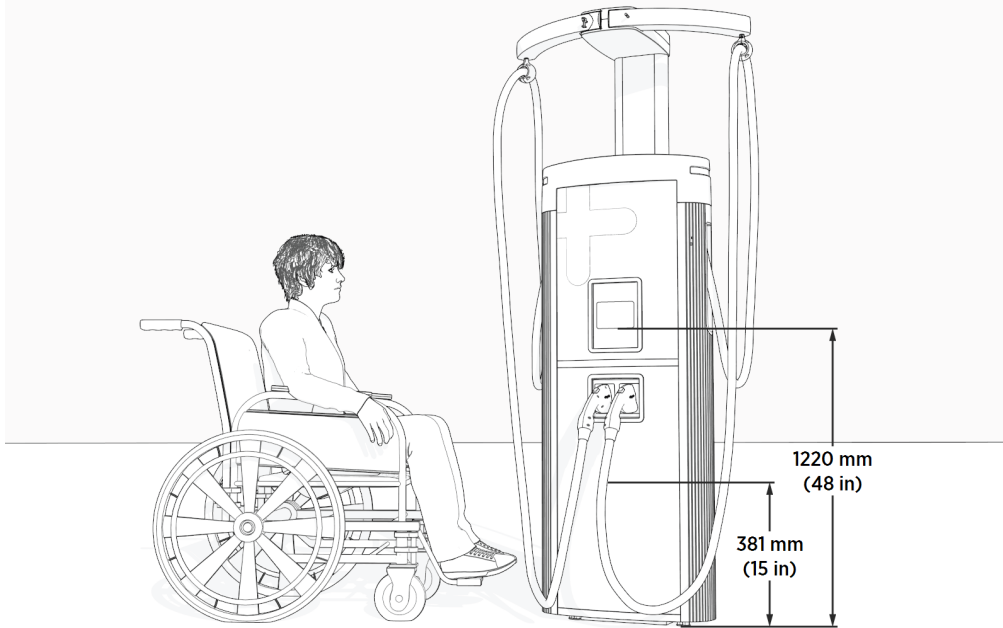

Signage

Refer to local and regional code to design the following elements for the site:

- Any required re-striping of parking spaces
- EV or Accessible EV signs
- EV or Accessible EV paint markings on and around the parking spaces

Electrical Design 4

This section provides electrical site design specifications for the Power Block and Power Link 2000.

Conduit and wire size are determined based on current. Service wiring in conduit or armored cable must be run as required to comply with local electrical codes. Consult national and local codes or a project engineer to determine the grade, quality, and size of the conduit or cable.

The Power Block is available in 200, 250, 350, and 500 A versions, each with its own rating labels.



NOTE: All wiring and conduit is supplied by the contractor unless otherwise indicated.



IMPORTANT: If a site requires surface conduit entry installation, contact ChargePoint before beginning work to obtain an approved installation method. If the station is being fed power by more than two Power Blocks, surface conduit entry installation is not permitted.

The following illustration shows sample electrical circuit requirements along with optional components for Express Plus with single Power Block and Power Link 2000.

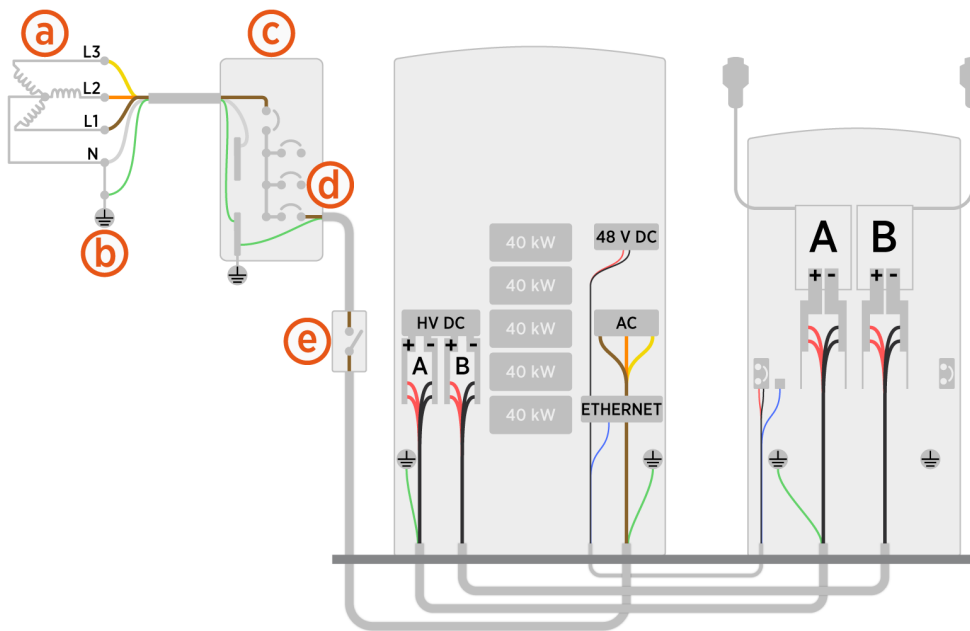

- (a) Transformer configuration
- (b) Ground connection
- (c) Electrical panel
- (d) Circuit breakers
- (e) AC disconnect switch (optional)

Power Block Electrical Supply Requirements

Power Block electrical supply requirements are given below.

Transformer Configuration

Refer to the following table for the transformer configuration.

	North America	Europe
Input rating	480 V AC, 3-phase, 260 A, 60 Hz	400 V AC, 3-phase, 310 A, 50 Hz
Electrical service configuration	277/480 V AC 3-phase grounded WYE (Y) configuration	230/400 V AC, 3-phase grounded WYE (Y) configuration
Product connection	Power Block must be connected to L1, L2, and L3 (neutral not required)	



NOTE: Delta (floating or grounded) is not supported.

Neutral is not required for system operation, however Neutral-to-ground bonding is required at the Main Distribution Panel (MDP) supplying the charging station.



IMPORTANT: This requirement is applicable to installations carried out within the province of Québec, Canada. Whether using a step-up or step-down autotransformer, refer to the 'Hydro-Québec bulletin - Choosing the right one 600/480 V transformer', that is publicly available, for specific guidance.

AC Breaker Size

Charging stations are considered continuous load devices (EVs draw maximum load for long durations). Therefore, electrical branch circuits to EV chargers must be sized at 125% of the load on each leg of a 3-phase panel for North American installations, in accordance with National Electric Code requirements. For other regions, refer to local code.

When planning multiple EV charging stations, it is best practice to segment non-continuous and continuous loads, with all branch circuits for EV charging on a dedicated electrical panel assembly with adequate circuit breakers. When sizing new electrical panels dedicated for EV charging, all branch circuits must support continuous load.

Each Power Block requires its own circuit breaker as follows:

Region	Nominal Voltage	Max. AC Input Current	Continuous Load (125%)	Breaker Size
Europe	400 V	315 A	394 A	400 A
North America	480 V	260 A	325 A	350 A and 400 A



NOTE: The Power Block has a short circuit current rating of 65 kA.

AC Disconnect Switch (optional)

A local AC disconnect switch, separate from the [shunt trip wiring](#), is recommended to be installed between each Power Block and the electrical panel. This is especially important if the main electrical panel or utility room is distant, out of line of sight, or has restricted access. For North America installations, refer to disconnect switch requirements per NEC Article 625, "Electric Vehicle Charging and Supply Equipment Systems". For other regions, refer to local code.

Shunt Trip Wiring (optional)

The Power Block provides a set of unpowered (dry) contacts to connect to an optional shunt trip device. These contacts are rated to 240 V AC and 6 Amps.

Wiring sections to and from the Power Block are deactivated when unsafe conditions are detected, such as unintended cover panel removal. A breaker reset is required any time the shunt trip is activated.

If installed, each Power Block must be wired to the shunt trip unit of its own upstream circuit breaker. Upstream AC power must be shut off at the panel to remove shock risk inside the Power Block. All shunt trip behavior is already hard-coded into the Power Block and has no programmable variables.

Emergency stop devices are governed by local and regional codes and may be required in some sites. If one is required by code or by the site, confirm specifications with your ChargePoint representative.

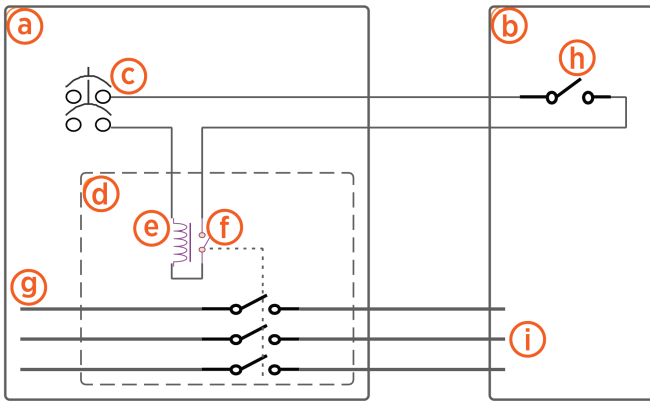

- (a)** Electrical panel
- (b)** Power Block
- (c)** Control voltage supply, maximum 240 V AC
- (d)** Shunt trip circuit breaker
- (e)** Shunt trip coil
- (f)** Auxiliary contacts (closed when main contacts are closed)
- (g)** 3-phase AC main
- (h)** Power Block shunt trip contacts, Normally Open (inside the auxiliary power supply, accessible on field wiring terminal block)
- (i)** 3-phase Power Block AC input

Grounding Requirements

Express Plus is a metallic accessible enclosure and relies on protective earth or ground connection for protection against electrical shock.

Express Plus must be connected to a grounded, metal, permanent wiring system. An equipment-grounding conductor must be run with circuit conductors and connected to an equipment-grounding terminal on the Power Block.

A grounding conductor that complies with applicable codes must be grounded to earth at the service equipment or, when supplied by a separate system, at the supply transformer, or may be grounded to an earth electrode. Ensure the grounding conductor complies with all applicable codes.

- North America: A service ground conductor must be run with circuit conductors and connected to an equipment-grounding terminal on the Power Block.
- Europe: Use TN-S, TN-C-S, or TT configurations. Express Plus doesn't have Residual Current Device (RCD) protection on the AC input side. When RCDs are to be installed, they should be minimum Type A and have leakage current tripping of at least 300 mA. This is because leakage current from Power Block can reach up to 200 mA at full power. The RCD must detect and disconnect all power lines.



NOTE: All Express Plus components (Power Block and Power Link 2000) must be bonded to one another in sequence.

Power Link 2000 Site Considerations

This section provides electrical site design considerations specific to the Power Link 2000.

Power Link 2000 Soft Shutdown

The soft shutdown function is an optional feature that can be installed as a way to stop a charge session on that Power Link 2000. It is not meant to safely service the Power Link 2000 or take the place of a HV disconnect switch.

To use this feature, the installer must select and mount a physical soft shutdown switch (one per Power Link 2000) with the following specifications:

- 2.5 mm² (14 AWG) THHN insulation building wire rated to 600 V
- Normally Open (NO) configuration
- Switch current of 2 ma
- Switch voltage of 48 V
- Gold contacts suggested

When creating the site drawings, consider where any soft shutdown switches should be positioned. If applicable, consider disability and accessibility regulations for your region when choosing switch locations.

NOTE: Soft shutdown switch requires a dedicated conduit. For more information, refer to [Civil and Mechanical Design](#).

To wire the soft shutdown switch to the Power Link 2000:

1. Run the wiring in a dedicated LV conduit into the Power Link 2000.
2. Route the wire away from other conductors carrying large currents.
3. Twist the two wires together, using a minimum of five twists per foot.
4. Connect the two terminals of the switch to the terminal block inside the Power Link 2000 labeled "Soft_Shutdown", next to the 48 VDC terminals (described in the *Express Plus Power Link 2000 Installation Guide*). The terminals do not have fixed polarity.

When the switch is closed, the Power Link 2000 software ends the current charging session with a normal stop, then opens DC contactors in the Power Link 2000. The station stays in this state regardless of station power, not allowing operation. Only a service technician can place the Power Link 2000 back into service after the switch is reset to Open.



WARNING: The HV DC wires from the Power Block could still be energized with the switch closed.

DC Maintenance Switch (optional)

A maintenance switch is highly recommended when more than one Power Link 2000s are connected to one or multiple Power Blocks to improve system uptime during maintenance. For Power Link 2000s that do not have a maintenance switch, servicing the station requires the Power Block(s) upstream to be powered off. This can affect system uptime and fleet scheduling.

If an external DC disconnect switch is used, then the switch must be configured with Normally Closed (NC) contact feedback wired into each Power Link 2000. The DC Maintenance Switch is an optional part available for the pedestal-mount Power Link 2000. It is ordered and shipped separately and is field installed.

Sequential Charging Kit

Dual output Power Link 2000s may be configured for sequential charging by field installing a Sequential Charging Kit. This kit allows Power Link 2000 to take a single power input and feed the power to either output in a sequential manner. The Sequential Charging Kit is ordered separately and is field installed.

Ethernet to USB Kit

Ethernet to USB is an optional kit that allows an Express Plus cluster (interconnected Power Blocks and Power Link 2000s) to have a hardwired Ethernet connection with an external network server.

The Ethernet to USB kit is installed within a single Power Link 2000, providing network connection for every node in the Express Plus cluster. The installation requires a conduit for the Ethernet cable, which must be run from the customer server or network equipment directly to the Power Link 2000.

This kit must be ordered separately and installed in the field.

Multiplex Kit

The Multiplex kit enables a single Express Plus cluster to deliver power to more than four ports simultaneously. Power Link 2000s with the Multiplex kit have four electrically distinct input landings.

Power Link 2000 Multiplex block diagram:

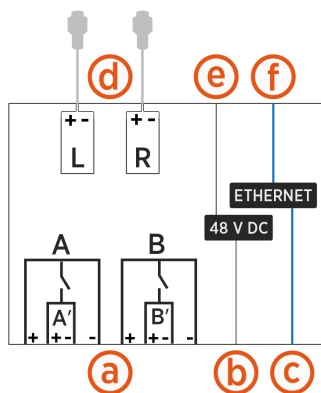

- (a) HV DC power landings (A, A', B, and B')
- (b) 48 V DC power input
- (c) Ethernet input
- (d) Single or dual HV DC charging cable outputs (L and R)
- (e) 48 V DC power output
- (f) Ethernet output

A Multiplex kit may be ordered and field-installed into a Power Link 2000.

NOTE:

- If installing a Multiplex kit in the field, note that the site must have appropriate conduit runs installed for the Multiplex Express Plus architecture. This may not be feasible at existing sites.
- Only pedestal-mount Power Link 2000s support the Multiplex configuration. Wall and overhead-mount Power Link 2000s do not support the Multiplex configuration.

Wiring Requirements

For full product specifications, refer to the *Express Plus Datasheet*. Using that data, ensure the installation location is equipped with service wiring that supports the Express Plus site's power requirements:

IMPORTANT:

- For AC and DC high voltage (HV), high current wiring, use copper or aluminum wires rated for 90 °C (194 °F).
 - AC high current wires can be THHN/THHW/THW-2/THWN-2 based on site condition (dry or wet) and rated for 600 V.
 - DC HV wires can be XHHW/XHHW-2 based on site condition (dry or wet) and rated for 1000 V.
- For low voltage (LV) DC wiring, use only copper wires (XHHW/XHHW-2 based on site condition, dry or wet) rated for 1000 V and 75 °C (167 °F).
- Use copper lugs for copper wires and aluminum lugs for aluminum wires. The lugs must be nickel, tin, or silver plated compression (not mechanical) lugs. Nickel-plated lugs installed with dielectric grease is recommended.



IMPORTANT: All AC and DC high voltage wires must undergo insulation testing as outlined in the *Express Plus High Voltage Wire Insulation Resistance Test Field Guide*.

Notes For All Regions:

Wire run lengths

- The maximum total HV DC wire run length from any Power Block to any connected Power Link 2000 must not exceed 200 m (656 ft). Refer to the cluster configuration provided by ChargePoint for interconnect details.

- LV DC wire and Ethernet runs between nodes (Power Block and Power Link 2000):
 - **For non-LCC cables:**
 - Without daisy-chained 48 V, the 48 V and Ethernet wire run length between Power Block and Power Link 2000 can be up to 200 m (656 ft).
 - With Power Link 2000 connected in a chain, the maximum total wire run length from the Power Block to the furthest Power Link 2000 is 160 m (525 ft). Contact ChargePoint for options if greater lengths are needed.
 - **For LCC cables:**
 - The 48 V and Ethernet wire run length between Power Block and Power Link 2000 can be up to 100 m (328 ft). Contact ChargePoint for options if greater lengths are needed.
- The maximum wire run length between a Power Link 2000 and an external network connection is 200 m (656 ft). Refer to the cluster configuration provided by ChargePoint for interconnect details.

Ethernet requirements

- For Ethernet communications between any two nodes (Power Link 2000 or Power Block) or to an external network connection:
 - Distances up to 100 m (328 ft) must use outdoor-rated Cat6 Shielded Twisted Pair (STP) cable. Lesser grades of cable do not provide the required noise immunity.
 - Distances between 100 m (328 ft) and 200 m (656 ft) must use Paige OSP Shielded GameChanger cable. See paigedatacom.com/gamechanger.
- An Ethernet cable connecting a Power Block and a Power Link 2000 must have the shield terminated at the Power Block end.
- An Ethernet cable connecting two Power Link 2000s must have the shield terminated at the end nearer to the Power Block.
- An Ethernet cable connecting a Power Block to another Power Block must have the shield terminated at only one end; either end can be terminated.

Conduit requirements

- The conduits must be sealed to maintain a Pollution Degree 2 environment.
- See [Power Block Concrete Mounting Template \(CMT\)](#), [Power Link 2000 Concrete Mounting Template \(CMT\)](#), [Power Block Surface Conduit Entry](#), and [Power Link 2000 Surface Conduit Entry](#) for the maximum size and quantity of conduits.

Other requirements

- Use one AC input feed per Power Block.
- Make sure to consider the height of bus bars above the concrete pad when determining the wire length required.

Power Block

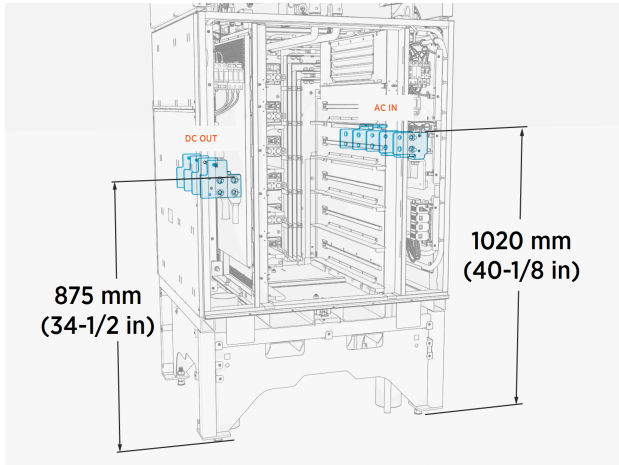

Power Link 2000

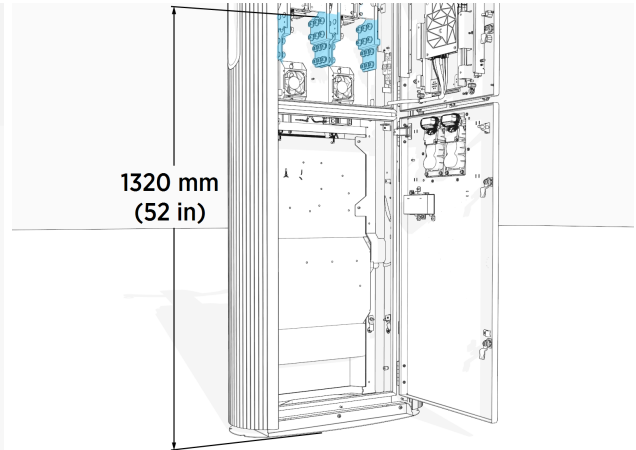

The following sections provide the maximum wire sizes that can be landed onto the Power Block and Power Link 2000 bus bars. All sizing assumes a maximum ambient temperature of 50 °C (122 °F).

Power Block

Power Block takes AC input from the site and provides DC and Ethernet output to Power Link 2000(s).

Wire Entry and Landing

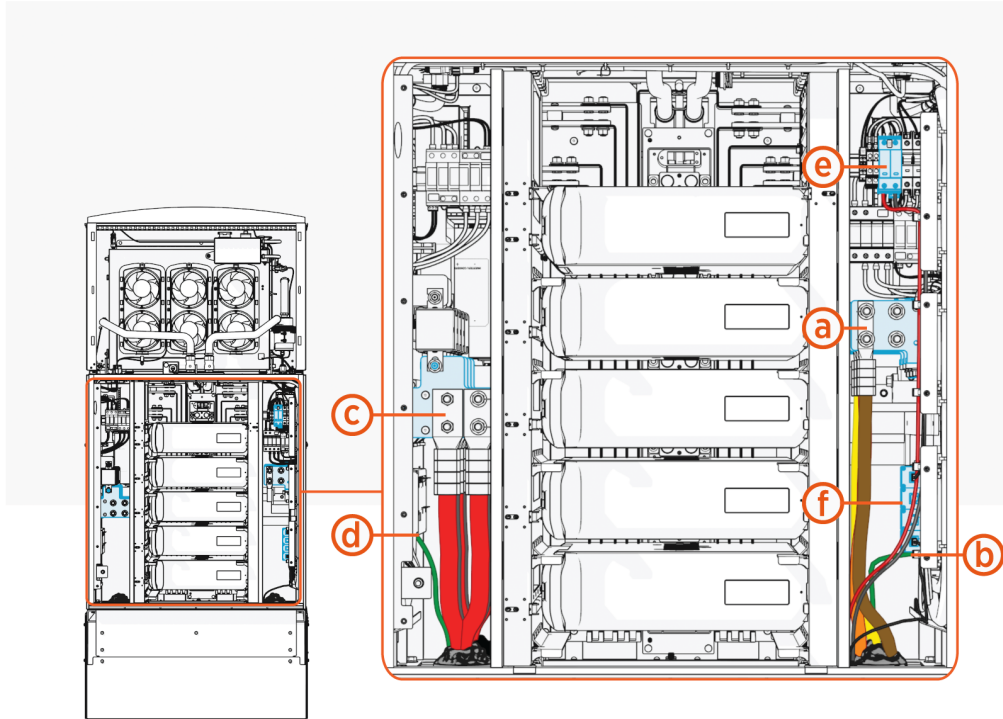

- (a) AC input
- (b) Ground input
- (c) HV DC output
- (d) Ground output
- (e) LV DC output
- (f) Ethernet output



IMPORTANT: Following are wire specifications for the Power Block, including the maximum quantity and size that the wire terminals can accommodate. All sizing assumes a maximum ambient temperature of 50 °C (122 °F). Where the maximum wire size is listed, the actual wire quantity and size must be chosen based on site-specific wiring requirements and in accordance with the maximum allowed conduit filling rate per local code.

AC Input Wire Quantity, Size, and Termination

Wire	Quantity	Size	Termination
AC input	Max. 12 wires (four per pole)	Max. 400 mm ² (750 MCM)	Lug: Long barrel and tongue with two holes spaced 44.5 mm (1-3/4 in) apart and sized for M12 studs Max. tongue width: 47.5 mm (1-7/8 in)
Ground	1 wire	Refer to the local code for size	Lug: Short barrel and tongue with single hole sized for M12 stud

DC Output Wire Quantity, Size, and Termination

Wire	Quantity	Size	Termination
Option 1 - HV DC outputs A and B	Max. 12 wires (six per output, three per pole)	See Power Link 2000 Wire Quantity, Size, and Termination	Lug: Long barrel and tongue with two holes 44.5 mm (1-3/4 in) apart and must fit M12 stud. Max. tongue width is 49 mm (1-15/16 in)
Option 2 - HV DC outputs A and B Multiplex	Max. 16 wires (eight per output, four per pole)	See Power Link 2000 Wire Quantity, Size, and Termination	Lug: Long barrel and tongue with two holes 44.5 mm (1-3/4 in) apart and must fit M12 stud. Max. tongue width is 49 mm (1-15/16 in)
Ground	Max. 4 wires (one per Power Link 2000)	See Power Link 2000 Wire Quantity, Size, and Termination	Lug: Short barrel and tongue with single hole and must fit M12 stud
LV DC output	See Power Link 2000 Wire Quantity, Size, and Termination		Stripped wire end
Ethernet	See Power Link 2000 Wire Quantity, Size, and Termination		RJ45 connector, shielded

Power Link 2000

The Power Block DC (HV and LV) and Ethernet outputs are the inputs for the Power Link 2000. The Power Link 2000 provides HV DC output to pantograph(s) and provides LV DC and Ethernet output to PD Controller(s). In some Express Plus architectures, Power Link 2000 also provides DC (HV and LV) and/or Ethernet output to another Power Link 2000.

Wire Entry and Landing - Pedestal-Mount Power Link 2000



NOTE: Depending on configuration, the pedestal-mount Power Link 2000 has one or two HV DC power paths, named A and B. Each power path has two wire landings, an upper landing and a lower landing. Power Link 2000s with a single charging cable are configured with Power Path B landings only.

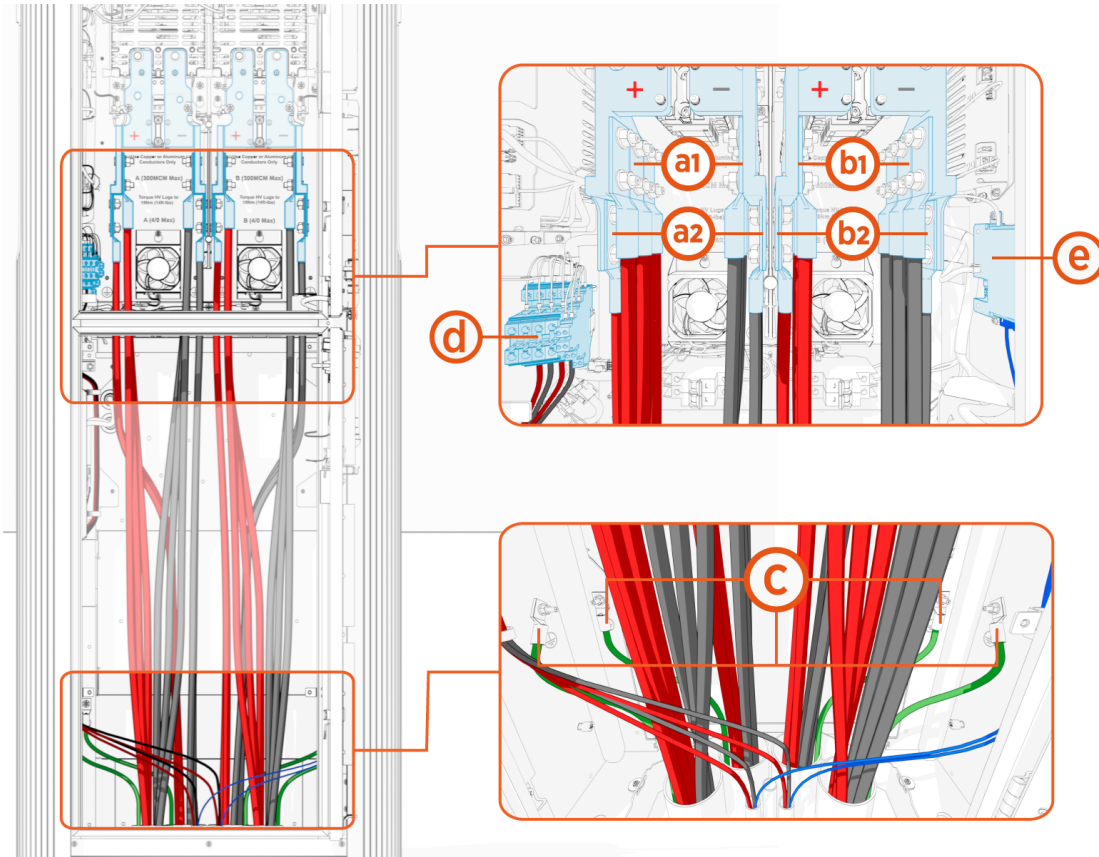

- (a1)** HV DC Power Path A, upper landing
- (a2)** HV DC Power Path A, lower landing
- (b1)** HV DC Power Path B, upper landing
- (b2)** HV DC Power Path B, lower landing
- (c)** Ground
- (d)** LV DC
- (e)** Ethernet

Wire Entry and Landing - Wall and Overhead-Mount Power Link 2000



NOTE: Depending on configuration, wall and overhead-mount Power Link 2000s have one or two HV DC Power Paths, named A and B. Each Power Path has two wire landings, an upper landing and a lower landing. Power Link 2000s with a single charging cable are configured with Power Path B landings only.

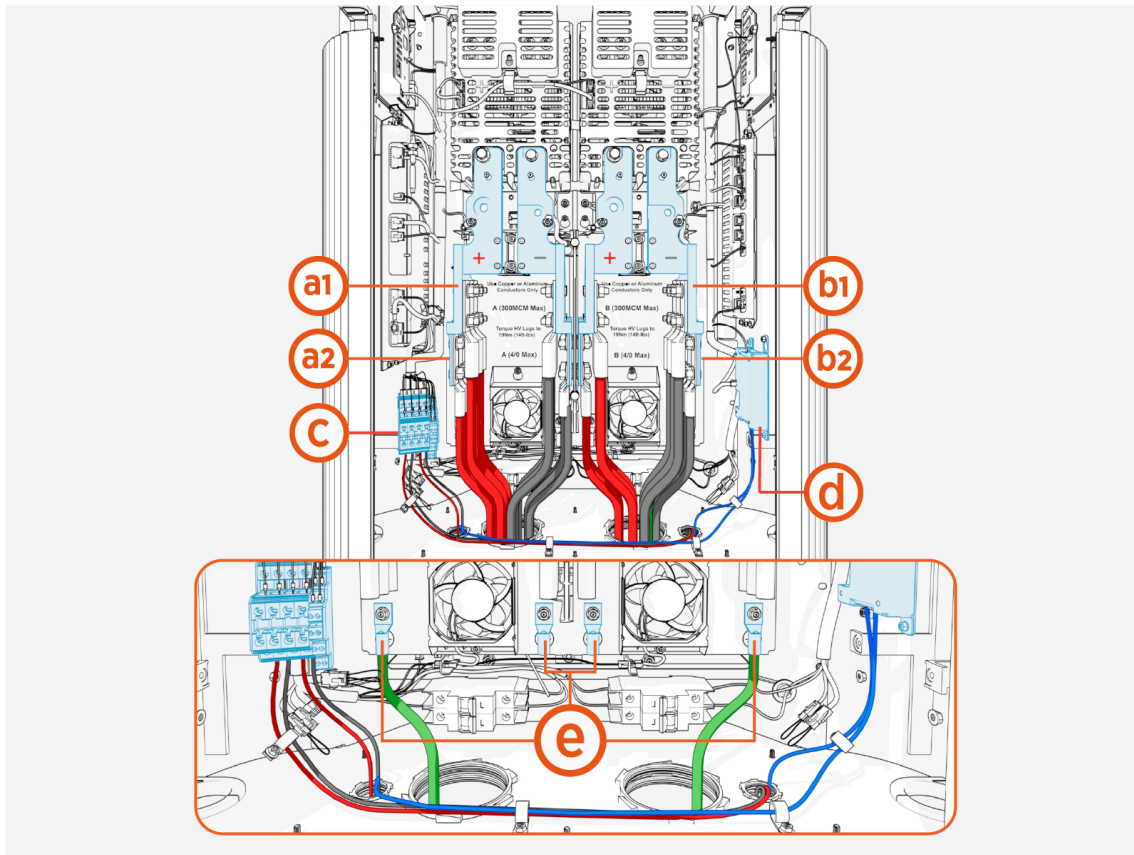

- (a1)** HV DC Power Path A, upper landing
- (a2)** HV DC Power Path A, lower landing
- (b1)** HV DC Power Path B, upper landing
- (b2)** HV DC Power Path B, lower landing
- (c)** LV DC
- (d)** Ethernet
- (e)** Ground

Wire Quantity, Size, and Termination



IMPORTANT: Following are wire specifications for the Power Link 2000, including the maximum quantity and size that the wire terminals can accommodate. All sizing assumes a maximum ambient temperature of 50 °C (122 °F). Where the maximum wire size is listed, the actual wire quantity and size must be chosen based on site-specific wiring requirements and in accordance with the maximum allowed conduit filling rate per local code.

Wire	Quantity	Size	Termination
Option 1 - HV DC Power Paths A and B (max. 500 A per landing)	Max. 12 wires per Power Path (three wires per pole on each landing)	Upper landings: Max. 150 mm ² (300 MCM)(*)	Lug: Long barrel and tongue with two holes spaced 44.5 mm (1.75 in) apart and sized for M12 studs. Max. lug tongue width: 31 mm (1.25 in) for upper landings, 25.9 mm (1 in) for lower landings. Aluminum lug max. tongue thickness: 10 mm (0.4 in) for upper landings, 5 mm (0.2 in) for lower landing.
		Lower landings: Max. 120 mm ² (4/0 AWG)	
Option 2 (**) - HV DC Multiplex Power Paths A and B (max. 500 A per landing)	Max. 8 wires per Power Path (two wires per pole on each landing)	Max. 240 mm ² (500 MCM)	Lug: Single hole compression lug with 12.7 mm (0.5 in) hole size. Max. lug tongue width: 39 mm (1.53 in).
Ground	Max. 6 wires (one per Power Block)	Refer to the local code for size; max. 50 mm ² (1/0 AWG)	Lug: Short barrel and tongue with single hole, sized for M6 stud.
LV DC	Max. 8 wires (four wire pairs; each pair has one wire per pole)	16 mm ² (6 AWG)	Stripped wire
Ethernet	Max. 4 cables	Outdoor-rated Cat6 STP(***)	RJ45 connector
Soft shutdown switch (****)	2 wires	2.5 mm ² (14 AWG)	Stripped wire



NOTE: (*) If utilizing both upper and lower landings, the maximum HV DC wire size is 120 mm² (4/0 AWG). (**) Only pedestal-mount Power Link 2000s support the Multiplex configuration. Wall and overhead-mount Power Link 2000s do not support the Multiplex configuration. (***) The required Ethernet cable type depends upon the cable run length. Refer to [Ethernet Requirements](#) for details. (****) Soft shutdown switch is an optional feature.

North American Wire, Voltage, and Current Ratings

	Inputs to Power Block		Power Block to Each Power Link 2000		
	AC and Ground	Shunt Trip	HV DC Output	48 V DC Output	Ethernet
Circuit Voltage	480 V AC	≤ 240 V	100 - 1000 V	48 V	--
Max. Current	260 A	6 A	200, 250, 350, or 500 A	32 A	--
Notes	Rated for 600 V L1, L2, L3, Ground		Rated for 1000 V		Outdoor rated Cat6 STP or Paige GameChanger(*)



NOTE: (*) The required Ethernet cable type depends upon the cable run length. See [Ethernet requirements](#).

UK and European Wire, Voltage, and Current Ratings

	Inputs to Power Block		Power Block to Each Power Link 2000		
	AC and Ground	Shunt Trip	HV DC Output	48 V DC Output	Ethernet
Circuit Voltage	400 V AC	< 240 V	200-1000 V	48 V	--
Max. Current	315 A	6 A	200, 250, 350, or 500 A	32 A	--
Notes	3p+E		Rated for 1000 V		Outdoor rated Cat6 STP or Paige GameChanger(*)



NOTE: (*) The required Ethernet cable type depends upon the cable run length. See [Ethernet requirements](#).

Connectivity 5

This section provides site connectivity requirements.

A consistently strong cellular signal is needed before installers can activate the vehicle charging station. Weak or sporadic signal can affect crucial aspects of the charging station, including:

- Accuracy in reporting
- Ability for drivers to use the mobile app
- Ability for customer support to troubleshoot problems
- Support for advanced features such as Power Management or Waitlist

A strong signal is also required for the ChargePoint Assure maintenance and management programs.

ChargePoint stations use cellular data connections to reach ChargePoint Cloud Services. This allows secure, PCI-compliant data connections without requiring any other form of internet connectivity at an install site or imposing additional network management responsibilities on a site host.

Each station has its own cellular connection.



NOTE: Cellular connection is needed only if there is no Ethernet to USB network connection.

Signal Strength and Quality

You must use a cellular signal detection device (such as a Siretta Snyder LTE or equivalent) to take signal strength readings at the exact proposed mounting location of the charging station. If the charging station does not have its own cellular connection, take the signal strength reading at the proposed mounting location of the gateway station.

In North America, ChargePoint products all support LTE bands 2, 4, and 5. The most commonly supported carriers to check during site evaluation are:

- US: AT&T, T-Mobile, and Verizon
- Canada: Rogers, Telus, and Bell

In Europe, ChargePoint products all support LTE bands 1, 3, 7, 8, and 20. 900 and 1800 MHz are also supported for 2G fallback. Partners vary by country.

You must test the LTE signal strength at the proposed mounting location of every gateway station and ensure the location meets the minimum RSRQ at -12.5 dB or better, for RSRP measured at -90 dBm or better. Refer to the graph for acceptable combinations.



NOTE: Cellular signal strength is measured in dBm, a logarithmic unit expressed as a negative number. Because dBm values are negative, a value closer to zero indicates a stronger signal. For example, -70 dBm represents a stronger signal than -85 dBm, while -90 dBm indicates a weaker signal than both.

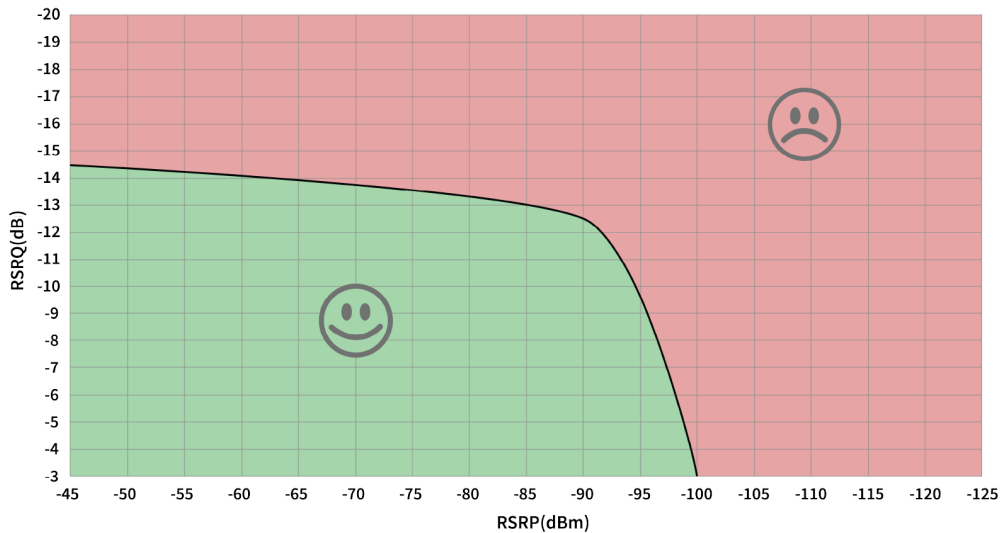

If the signal strength is weaker than this, take cellular readings at the location where any cellular signal booster antennas will be installed. Ensure enough signal exists for that repeater model. Install repeaters to boost the strength of the cellular signals. Repeaters are often required when installing charging stations in an underground garage or enclosed parking structure.

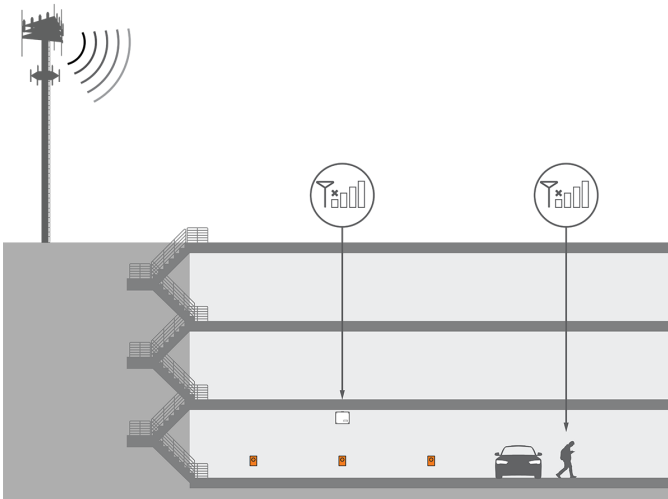

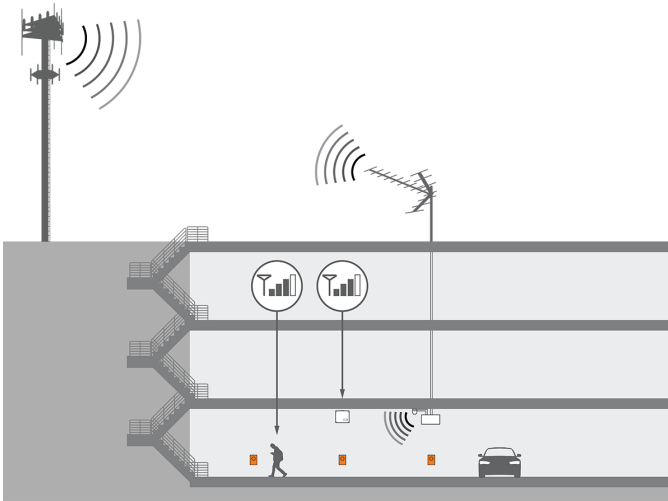

For other regions, or if the site does not have strong signal on these bands, contact your ChargePoint representative for additional solutions.

ChargePoint strongly recommends a consultation with a cellular connectivity specialist before all installations. A consultation can verify:

- Service with a supported carrier on a supported LTE band
- Available signal and local noise levels on applicable bands
- Site changes to correctly meet your needs, both for station bandwidth and other phone coverage for customer or tenant satisfaction

Repeaters

Some sites require repeaters to ensure strong signal to all stations. If a repeater is required, look for a model with these features:

- Specifically LTE-compatible on the listed bands
- Multi-carrier
- Multi-band
- Not already dedicated to FirstNet or other first responder-specific networks
- Auto-gain recommended



NOTE: Do not rely on readings taken with a cell phone when conducting site surveys. Many signal boosters and network extenders may not be compatible with ChargePoint hardware, including certain types of Distributed Antenna Systems (DAS), micro/nano/pico/femto-cells, and carrier- or band-specific signal boosters.

Repeaters are not allowed in France. Contact the French service provider for more information.

Limited Warranty Information and Disclaimer

The Limited Warranty you received with your charging station is subject to certain exceptions and exclusions. For example, your use of, installation of, or modification to, the ChargePoint® charging station in a manner in which the ChargePoint® charging station is not intended to be used or modified will void the limited warranty. You should review your limited warranty and become familiar with the terms thereof. Other than any such limited warranty, the ChargePoint products are provided "AS IS," and ChargePoint, Inc. and its distributors expressly disclaim all implied warranties, including any warranty of design, merchantability, fitness for a particular purposes and non-infringement, to the maximum extent permitted by law.

Limitation of Liability

CHARGEPOINT IS NOT LIABLE FOR ANY DIRECT, INDIRECT, INCIDENTAL, SPECIAL, PUNITIVE OR CONSEQUENTIAL DAMAGES, INCLUDING WITHOUT LIMITATION LOST PROFITS, LOST BUSINESS, LOST DATA, LOSS OF USE, OR COST OF COVER INCURRED BY YOU ARISING OUT OF OR RELATED TO YOUR PURCHASE OR USE OF, OR INABILITY TO USE, THE CHARGING STATION, UNDER ANY THEORY OF LIABILITY, WHETHER IN AN ACTION IN CONTRACT, STRICT LIABILITY, TORT (INCLUDING NEGLIGENCE) OR OTHER LEGAL OR EQUITABLE THEORY, EVEN IF CHARGEPOINT KNEW OR SHOULD HAVE KNOWN OF THE POSSIBILITY OF SUCH DAMAGES. IN ANY EVENT, THE CUMULATIVE LIABILITY OF CHARGEPOINT FOR ALL CLAIMS WHATSOEVER RELATED TO THE CHARGING STATION WILL NOT EXCEED THE PRICE YOU PAID FOR THE CHARGING STATION. THE LIMITATIONS SET FORTH HEREIN ARE INTENDED TO LIMIT THE LIABILITY OF CHARGEPOINT AND SHALL APPLY NOTWITHSTANDING ANY FAILURE OF ESSENTIAL PURPOSE OF ANY LIMITED REMEDY.

FCC Compliance Statement

This equipment has been tested and found to comply with the limits for a Class B digital device, pursuant to part 15 of the FCC Rules. These limits are designed to provide reasonable protection against harmful interference when the equipment is operated in a residential installation. This equipment generates, uses, and can radiate radio frequency energy and, if not installed and used in accordance with the instruction manual, may cause harmful interference to radio communications.

Important: Changes or modifications to this product not authorized by ChargePoint, inc., could affect the EMC compliance and revoke your authority to operate this product.

Exposure to Radio Frequency Energy: The radiated power output of the 802.11 b/g/n radio and cellular modem (optional) in this device is below the FCC radio frequency exposure limits for uncontrolled equipment. The antenna of this product, used under normal conditions, is at least 20 cm away from the body of the user. This device must not be co-located or operated with any other antenna or transmitter by the manufacturer, subject to the conditions of the FCC Grant.

ISED (formerly Industry Canada)

This device complies with the licence-exempt RSS standard(s) of Innovation, Science and Economic Development Canada (ISED). Operation is subject to the following two conditions: (1) this device may not cause interference, and (2) this device must accept any interference, including interference that may cause undesired operation of the device.

Cet appareil est conforme aux flux RSS exemptés de licence d'Innovation, Sciences et Développement économique Canada (ISDE). L'exploitation est autorisée aux deux conditions suivantes : (1) l'appareil ne doit pas produire de brouillage, et (2) l'utilisateur de l'appareil doit accepter.

Radiation Exposure Statement: This equipment complies with the IC RSS-102 radiation exposure limits set forth for an uncontrolled environment. This equipment should be installed and operated with a minimum distance of 20 cm between the radiator and your body.

Énoncé d'exposition aux rayonnements: Cet équipement est conforme aux limites d'exposition aux rayonnements ioniques RSS-102 Pour un environnement incontrôlé. Cet équipement doit être installé et utilisé avec un Distance minimale de 20 cm entre le radiateur et votre corps.

FCC/IC Compliance Labels

Visit chargepoint.com/labels.